

**Werkstatthandbuch**

**Workshop Manual**

**Manuel d'Atelier**

**Manuale d'officina**

**BFM 1012/1013**

**0297 9771**

Gegenüber Darstellungen und Angaben dieses Werkstatthandbuches sind technische Änderungen, die zur Verbesserung der Motoren notwendig werden, vorbehalten. Nachdruck und Vervielfältigung jeglicher Art, auch auszugsweise, bedarf unserer schriftlichen Genehmigung.

---

In view of continuous design improvements or changes, the technical specifications and the illustrations shown in this Workshop Manual are subject to alteration. Reprinting and reproduction, in part or in whole, are subject to our written approval.

---

Sous réserve de modifications techniques nécessaires à l'amélioration des moteurs présentés par des illustrations et des indications référencées dans ce Manuel d'Atelier. Réimpression et reproduction même partielle, quelle qu'en soit la nature, interdites sans l'autorisation écrite de nos service.

---

Ci riserviamo il diritto di apportare sia ai dati tecnici che alle descrizioni contenute nel presente manuale d'officina le modifiche che si sono eventualmente rese necessarie per migliorare i motori. Per ristamparlo o riprodurlo in qualsiasi forma, anche parziale, è necessaria la nostra autorizzazione scritta.





**Knowing it's DEUTZ.**

**DEUTZ AG**  
**Service-Technik**  
**Instandhaltungstechnik Motoren**  
**Deutz-Mülheimer Straße 147-149**  
**D - 51057 Köln**  
**Telefon: 0221 - 822 - 0**  
**Fax: 0221 - 822 - 5358**  
**<http://www.deutz.de>**

**Printed in Germany**  
**All rights reserved**  
**1st Edition, © 05/2000**  
**Best.-Nr. 0297 9771**

## VORWORT

Die sachgerechte Ausführung von Reparatur- und Einstellarbeiten ist Voraussetzung für einen zuverlässigen Motorbetrieb.

In diesem Werkstatthandbuch sind die zweckmäßigen Arbeitsabläufe für anfallende Reparatur- und Einstellarbeiten an Motor und Motorbauteilen beschrieben. Dabei wird vorausgesetzt, daß die Arbeiten von qualifiziertem Fachpersonal durchgeführt werden.

Bei der Gestaltung des Werkstatthandbuches wurden im Sinne einer schnellen Erfassung der Inhalte zusätzlich zu den knapp gehaltenen beschreibenden Texten Bildzeichen gesetzt, die den jeweils behandelten Arbeitsgang visualisieren.

Betriebs- und Wartungshinweise sind der entsprechenden Betriebsanleitung zu entnehmen.

Zur Ersatzteilbestellung ist die jeweilige Ersatzteilliste zugrunde zu legen.

Das vorliegende Werkstatthandbuch unterliegt keinem Änderungsdienst. Änderungen werden jeweils bei Neuauflage eingearbeitet.

Beachten Sie bei Reparaturen die Hinweise unserer Technischen Rundschreiben.

Allgemeine Hinweise:

- Lesen und beachten Sie die Informationen dieses Werkstatthandbuches. Sie vermeiden Unfälle und verfügen über einen funktionstüchtigen und einsatzbereiten Motor.
- Stellen Sie sicher, daß dieses Werkstatthandbuch jedem an Reparatur- oder Einstellarbeiten Beteiligten zur Verfügung steht und daß der Inhalt verstanden wird.
- Die Nichtbeachtung dieser Reparaturanleitung kann zu Funktionsstörungen und Motorschäden sowie Verletzungen von Personen führen, für die vom Hersteller keine Haftung übernommen wird.
- Die einschlägigen Unfallverhütungsvorschriften sowie die sonstigen allgemeinen anerkannten sicherheitstechnischen und arbeitsmedizinischen Regeln sind einzuhalten.
- Voraussetzung für die fachgerechte Reparatur ist die Verfügbarkeit aller erforderlichen Ausrüstungen, Hand- und Spezialwerkzeuge sowie deren einwandfreier Zustand.
- Höchste Wirtschaftlichkeit, Zuverlässigkeit und lange Lebensdauer ist nur bei Verwendung von Original Teilen der DEUTZ AG sichergestellt.
- Motorteile wie Federn, Klammern, elastische Halteringe etc. beinhalten bei unsachgemäßer Behandlung erhöhte Verletzungsgefahr.
- Die Instandsetzung des Motors muß der bestimmungsgemäßen Verwendung - definiert durch den Gerätehersteller - entsprechen. Bei Umbauten dürfen nur von der DEUTZ AG für den jeweiligen Verwendungszweck freigegebene Teile eingesetzt werden.

# FOREWORD

Reliable engine operation is dependent on properly executed repairs as well as adjustment work.

This Workshop Manual describes the appropriate operations for any repair and adjustment work on the engine and engine components. It is presumed that this work will be carried out by qualified personnel.

This operation manual has been designed for quick and easy understanding. Therefore the concise text passages are accompanied by pictographs to illustrate the relevant operation.

The Workshop Manual has been laid out to ensure quick comprehension of the contents, i. e. illustrations have been placed adjacent to the brief text passages to clearly show the working operations.

Aspects of operation and maintenance are dealt with in the respective Operation Manual.

For spare parts orders the respective spare parts catalogue should be referred to.

This Workshop Manual is not subject to engineering change service and is valid until next issue.

Therefore please refer to the information in our Technical Circulars when carrying out repairs.

General information:

- Please read carefully and observe the instructions given in this Workshop Manual to avoid accidents and ensure that your engine always functions properly and reliably.
- Make sure that this Workshop Manual is readily available for all those carrying out repairs or adjustments and that the contents are well understood.
- Non-compliance with these repair instructions may result in malfunction and engine damage as well as personal injuries for which the manufacturer shall not accept any liability.
- The accident prevention regulations and all other generally recognized regulations on safety and occupational medicine are to be observed.
- A prerequisite for successful repair is that all required equipment, hand and special tools are available and in perfect working order.
- Optimal operation economy, reliability and durability of the engine can only be ensured when genuine parts of DEUTZ AG are used.
- Engine components such as springs, clamps, snap rings, etc. may cause injury if not handled with care.
- Engine repairs must be carried out in accordance with intended use as defined by the equipment manufacturer. For conversions, only parts approved by DEUTZ AG for a specific purpose should be used.



# PRÉFACE

Un fonctionnement fiable du moteur suppose l'exécution en bonne et due forme des travaux de réparation et de réglage.

Le présent Manuel d'atelier décrit la suite des travaux de réparation et de réglage à effectuer sur le moteur et ses éléments. Cela suppose que les travaux sont réalisés par un personnel spécialisé et qualifié.

En vue d'une compréhension rapide du contenu, le manuel d'atelier comporte, en plus des textes brefs, des symboles visualisant l'opération à réaliser.

Le manuel d'atelier a été conçu de manière à assurer une rapide compréhension des textes concis agrémentés d'illustrations et de symboles visualisant l'opération à effectuer.

Les indications relatives au service et à l'entretien figurent dans les instructions de service correspondantes.

Pour la commande de pièces de rechange, il convient de se baser sur la liste des pièces de rechange correspondante.

Le présent manuel d'atelier n'est soumis à aucun service de modifications. Les modifications seront incorporées à chaque réédition du Manuel.

Pour les réparations, veuillez respecter les indications de nos circulaires techniques.

Remarques générales:

- Veuillez lire attentivement les informations du présent Manuel d'Atelier et en tenir compte. Vous éviterez ainsi des accidents et disposerez en même temps d'un moteur fonctionnel et en parfait état de marche.
- Assurez-vous que chaque personne chargée des travaux de réparation et de mise au point dispose bien de ce Manuel d'Atelier et en comprenne bien le contenu.
- Le non-respect de ces instructions de réparation peut entraîner des pannes, avaries de moteur et accidents de personnes, pour lesquels le constructeur ne peut en aucun cas assumer la responsabilité.
- Il convient de respecter les consignes générales de sécurité et de prévention des accidents en vigueur.
- La condition préalable de la bonne exécution des réparations est la mise à disposition de tous les équipements, outillages manuels et spéciaux requis, en parfait état de fonctionnement.
- Seule l'utilisation de pièces de rechange d'origine DEUTZ AG garantit une rentabilité et fiabilité optimales ainsi qu'une longue durée de vie.
- Les éléments du moteur notamment les ressorts, attaches, bagues élastiques etc., peuvent entraîner, en cas de non-respect des prescriptions, des blessures graves.
- La remise en état du moteur doit répondre à son utilisation propre, définie par le constructeur de l'engin. En cas de modification, seules les pièces autorisées par DEUTZ AG dans le cas de l'application concernée, peuvent être utilisées.

# P R E F A Z I O N E

La corretta esecuzione dei lavori di riparazione o di regolazione è un presupposto indispensabile per un sicuro funzionamento del motore.

Nel presente manuale sono descritte le sequenze più convenienti per l'esecuzione di lavori di riparazione o regolazione su motori o suoi componenti. L'impiego di personale qualificato è il presupposto fondamentale per l'esecuzione di tali lavori.

Allo scopo di permettere una rapida comprensione del contenuto, oltre alle descrizioni volutamente sintetiche, nel manuale sono state inserite dei simboli che chiariscono visivamente le varie fasi di lavoro.

Per quanto riguarda l'esercizio e la manutenzione si rimanda al libretto di istruzioni.

Per le ordinazioni di parti di ricambio ci si deve basare sul relativo listino.

Per il presente manuale d'officina non sono previsti aggiornamenti. Le eventuali modifiche verranno apportate alle edizioni successive.

Nel caso di riparazioni si devono consultare le nostre circolari tecniche.

Informazioni generali:

- Leggere attentamente ed osservare le istruzioni contenute nel presente manuale d'officina. Si eviteranno pertanto incidenti e si disporrà di un motore funzionale ed affidabile.
- Assicurarsi che questo manuale d'officina sia a disposizione di tutte le persone che eseguono lavori di riparazione e messa a punto e ne abbiano ben compreso il contenuto
- La non osservanza di queste istruzioni per le riparazioni può essere causa di disfunzioni o guasti del motore, oppure di danni a persone o cose, per i quali il costruttore non può essere chiamato a rispondere.
- Si devono osservare le prescrizioni in vigore per la prevenzione degli incidenti, come pure le regole generali di sicurezza e medicina del lavoro.
- Presupposto fondamentale per una riparazione eseguita a regola d'arte è la disponibilità di tutta l'attrezzatura necessaria, nonché degli utensili speciali perfettamente funzionanti.
- Soltanto l'impiego di parti originali della DEUTZ AG può assicurare la massima economicità, affidabilità e durata di un motore.
- Piccoli componenti del motore, come molle, morsetti, anelli elastici di fissaggio, ecc. possono costituire, se non usati in modo corretto, un elevato pericolo di incidenti.
- La riparazione del motore deve corrispondere all'uso per cui è previsto, a sua volta definito dal costruttore dell'attrezzo. Nel caso di modifiche possono venire impiegate soltanto parti approvate dalla DEUTZ AG per quello specifico uso.

---

**Technische Daten / Bildzeichenerklärung**  
**Specification data / Key to symbols**  
**Caractéristiques techniques / Légende des symbols**  
**Dati tecnici / Spiegazione dei simboli**

**1**

---

**Prüfen und Einstellen**  
**Checking and adjusting**  
**Contrôle et réglage**  
**Controlli e regolazioni**

**2**

---

**Bauteile instand setzen**  
**Repair of components**  
**Mise en état des composants**  
**Riparazione di componenti**

**3**

---

**Demontage und Montage, Motor komplett**  
**Disassembly and reassembly of complete engine**  
**Démontage et montage moteur complet**  
**Smontaggio e rimontaggio completo del motore**

**4**

---

**Werkzeuge**  
**Tools**  
**Outils**  
**Attrezzi**

**5**



**Technische Daten**

**Specification data**

**Caractéristiques techniques**

**Dati tecnici**

**BFM 1012/1013**

**Hinweis zum Gebrauch des Werkstatthandbuchs**

In diesem Werkstatthandbuch sind alle technischen Daten, Einstellwerte und Anziehvorschriften den Stellen zugeordnet, wo sie bei Servicearbeiten, De- und Montage am Motor benötigt werden.

**Notes for the user of this Workshop Manual**

In this Workshop Manual all specification data, adjustment values and tightening specifications are allocated to those parts where they are needed for service work, disassembly and reassembly on the engine.

**Remarque quant à l'utilisation du Manuel d'atelier**

Dans le présent Manuel d'atelier, toutes les caractéristiques techniques, valeurs de réglage et préconisations de serrage nécessaires se trouvent dans les chapitres correspondant aux travaux de service après-vente et montage et démontage du moteur.

**Consigli per l'uso del manuale d'officina**

Nel presente manuale d'officina tutti i dati tecnici, valori di regolazione e prescrizioni di serraggio sono coordinati con quei punti in cui se ne avrà bisogno per eseguire lavori di assistenza, smontaggio e rimontaggio del motore.





**Werkstatthandbuch BFM 1012/E, BFM 1013/E**

**Deutsch**

<b>1. Technische Daten</b>	<b>Seite</b>
Techn. Daten _____	1.00.01 - 1.00.07
Ventilspieleinstellschema _____	1.00.09
Reihenfolge beim Anziehen der Zylinderkopfschrauben _____	1.00.11
Ausgleichscheibendicke für Förderbeginn ermitteln bei Bosch-Einspritzpumpe _____	1.00.13
Ausgleichscheibendicke für Förderbeginn ermitteln bei BFM 1012 Bosch-Einspritzpumpentausch im Servicefall. Grundmaß Lo = 109 mm _____	1.00.15
Ausgleichscheibendicke für Förderbeginn ermitteln bei BFM 1012 Bosch-Einspritzpumpentausch im Servicefall. Grundmaß Lo = 119 mm _____	1.00.15.1
Ausgleichscheibendicke für Förderbeginn ermitteln bei BFM 1013 Bosch-Einspritzpumpentausch im Servicefall. Grundmaß Lo = 143 mm _____	1.00.17
Korrigiertes Einbaumaß und EP-Code ermitteln bei Bosch Einspritzpumpe _____	1.00.19
Bildzeichenerklärung _____	1.00.21

**English**

<b>1. Specification data</b>	<b>Page</b>
Specification data _____	1.00.01 - 1.00.07
Schematic for valve clearance adjustment _____	1.00.09
Tightening order for cylinder head bolts _____	1.00.11
Shim thickness for determining commencement of delivery with Bosch injection pump _____	1.00.13
Shim thickness for determining commencement of delivery with Bosch injection pump replacement on BFM 1012 in case of service. Standard dimensions Lo = 109 mm _____	1.00.15
Shim thickness for determining commencement of delivery with Bosch injection pump replacement on BFM 1012 in case of service. Standard dimensions Lo = 119 mm _____	1.00.15.1
Shim thickness for determining commencement of delivery with Bosch injection pump replacement on BFM 1013 in case of service. Standard dimensions Lo = 143 mm _____	1.00.17
Determining corrected installation dimension and EP code with Bosch injection pump _____	1.00.19
Key to symbols _____	1.00.21

Werkstatthandbuch BFM 1012/E, BFM 1013/E

Français

<b>1. Caractéristiques techniques</b>	<b>Page</b>
Caractéristiques techniques _____	1.00.01 - 1.00.07
Schéma de réglage des soupapes _____	1.00.09
Ordre à respecter lors du préserrage et serrage définitif des vis de culasse _____	1.00.11
Calcul de l'épaisseur des rondelles de compensation pour le début d'injection sur pompe d'injection Bosch _____	1.00.13
Calcul de l'épaisseur des cales d'épaisseur utilisées pour remplacement de la pompe d'injection Bosch BFM 1012 en cas d'intervention SAV.	
Cote de base Lo = 109 mm _____	1.00.15
Calcul de l'épaisseur des cales d'épaisseur utilisées pour remplacement de la pompe d'injection Bosch BFM 1012 en cas d'intervention SAV.	
Cote de base Lo = 119 mm _____	1.00.15.1
Calcul de l'épaisseur des cales d'épaisseur utilisées pour remplacement de la pompe d'injection Bosch BFM 1013 en cas d'intervention SAV.	
Cote de base Lo = 143 mm _____	1.00.17
Calcul des cotes de montage corrigées et du code EP pour pompe d'injection Bosch _____	1.00.19
Explication des légendes _____	1.00.21

Italiano

<b>1. Dati tecnici</b>	<b>Pagina</b>
Dati tecnici _____	1.00.01 - 1.00.07
Schema di registrazione del gioco delle valvole _____	1.00.09
Sequenza del serraggio delle viti delle teste dei cilindri _____	1.00.11
Determinazione dello spessore delle rondelle per l'inizio di mandata con pompa d'iniezione Bosch _____	1.00.13
Determinazione dello spessore delle rondelle per l'inizio di mandata nel caso di sostituzione di una pompa di iniezione Bosch sul motore BFM 1012. Misura base Lo = 109 mm _____	1.00.15
Determinazione dello spessore delle rondelle per l'inizio di mandata nel caso di sostituzione di una pompa di iniezione Bosch sul motore BFM 1012. Misura base Lo = 119 mm _____	1.00.15.1
Determinazione dello spessore delle rondelle per l'inizio di mandata nel caso di sostituzione di una pompa di iniezione Bosch sul motore BFM 1013. Misura base Lo = 143 mm _____	1.00.17
Determinazione delle misure d'ingombro corrette e del codice EP per le pompe di iniezione Bosch _____	1.00.19
Spiegazione dei simboli _____	1.00.21





**Werkstatthandbuch BFM 1012/E, BFM 1013/E**

Deutsch	English	Français	Italiano
<p>Motorgewicht nach DIN 70020 - A</p> <p>ca. kg</p>	<p>Engine weight acc. to DIN 70020 - A</p> <p>approx. kg</p>	<p>Poids du moteur selon DIN 70020 - A</p> <p>approx. kg</p>	<p>Peso del motore secondo DIN 70020 - A</p> <p>circa kg</p>
<p>Gesamthubvolumen</p> <p>cm<sup>3</sup></p>	<p>Engine swept volume</p> <p>cm<sup>3</sup></p>	<p>Cylindrée totale</p> <p>cm<sup>3</sup></p>	<p>Cilindrata totale</p> <p>cm<sup>3</sup></p>
<p>Bohrung</p> <p>mm</p>	<p>Bore</p> <p>mm</p>	<p>Alésage</p> <p>mm</p>	<p>Alesaggio</p> <p>mm</p>
<p>Hub</p> <p>mm</p>	<p>Stroke</p> <p>mm</p>	<p>Course</p> <p>mm</p>	<p>Corsa</p> <p>mm</p>
<p>Drehrichtung</p>	<p>Direction of rotation</p>	<p>Sens de rotation</p>	<p>Senso di rotazione</p>
<p>Nenndrehzahl</p> <p>max. 1/min</p>	<p>Rated speed</p> <p>max. rpm</p>	<p>Régime nominal</p> <p>maxi tr/mn</p>	<p>Regime nominale</p> <p>max. 1/min</p>
<p>niedrigste Leerlaufdrehzahl 1/min</p>	<p>Minimum idle speed rpm</p>	<p>Ralenti extrême</p> <p>tr/mn</p>	<p>Regime minimo a vuoto 1/min</p>
<p>Arbeitsweise</p>	<p>Working cycle</p>	<p>Principe de fonction- nement</p>	<p>Ciclo di funzionamento</p>

**Werkstatthandbuch BFM 1012/E, BFM 1013/E**

BF4M 1012 BF4M 1013	BF4M 1012 E BF4M 1013 E	BF6M 1012 BF6M 1013	BF6M 1012 E BF6M 1013 E
inklusive Kühlsystem incl. cooling system y compris circuit de réfrig. incluso sist. raffredd.	ohne Kühlsystem without cooling system sans circuit de réfrig. senza sist. raffredd.	inklusive Kühlsystem incl. cooling system y compris circuit de réfrig. incluso sist. raffredd.	ohne Kühlsystem without cooling system sans circuit de réfrig. senza sist. raffredd.
380    BFM 1012 480    BFM 1013	330    BFM 1012 E 430    BFM 1013 E	490    BFM 1012 625    BFM 1013	435    BFM 1012 E 570    BFM 1013 E
3192    BFM 1012/ E 4764    BFM 1013/ E		4788    BFM 1012/ E 7146    BFM 1013/ E	
		94        BFM 1012/ E 108       BFM 1013/ E	
		115       BFM 1012/ E 130       BFM 1013/ E	
auf Schwungrad gesehen links When facing flywheel counter-clockwise Vu sur volant à gauche in senso anti-orario guardando il volano			
		2500     BFM 1012/ E 2300     BFM 1013/ E	
650			
Viertakt - Diesel Four-stroke diesel Diesel 4 temps diesel a 4 tempi			

**Werkstatthandbuch BFM 1012/E, BFM 1013/E**

Deutsch	English	Français	Italiano
Verbrennungs- verfahren	Combustion system	Principe de combustion	Sistema di combustione
Verdichtungs- verhältnis	Compression ratio	Taux de compression	Rapporto di compressione
Kompressionsdruck  bar	Compression pressure  bar	Compression  bars	Pressione di compressione bar
Zündfolge	Firing order	Ordre d'allumage	Ordine di accensione
Abmessungen des Motors mit Anschlußgehäuse (normal)	Dimensions of engine incl. standard adapter housing	Dimensions du moteur avec carter d'adaption standard	Dimensioni motore compresa campana di collegamento (normale)
größte Länge  mm	Max. length  mm	Longueur HT  mm	Lunghezza massima  mm
größte Breite  mm	Max. width  mm	Largeur HT  mm	Larghezza massima  mm
größte Höhe  mm	Max. height  mm	Hauteur HT  mm	Altezza massima  mm

Werkstatthandbuch BFM 1012/E, BFM 1013/E

BF4M 1012 BF4M 1013	BF4M 1012 E BF4M 1013 E	BF6M 1012 BF6M 1013	BF6M 1012 E BF6M 1013 E
Direkteinspritzung Direct injection Injection directe Iniezione diretta			
		17,5 17,6	BFM 1012/ E BFM 1013/ E
		28 - 33 30 - 38	BFM 1012/ E BFM 1013/ E
1 - 3 - 4 - 2		1 - 5 - 3 - 6 - 2 - 4	
874 BFM 1012 945 BFM 1013	775 BFM 1012 E 862 BFM 1013 E	1120 BFM 1012 1239 BFM 1013	1003 BFM 1012 E 1146 BFM 1013 E
678 BFM 1012 685 BFM 1013	540 BFM 1012 E 616 BFM 1013 E	678 BFM 1012 760 BFM 1013	540 BFM 1012 E 622 BFM 1013 E
743 BFM 1012 818 BFM 1013	742 BFM 1012 E 844 BFM 1013 E	834 BFM 1012 868 BFM 1013	827 BFM 1012 E 852 BFM 1013 E

**Werkstatthandbuch BFM 1012/E, BFM 1013/E**

Deutsch	English	Français	Italiano
Steuerzeiten ohne Stößel- und Ventilspiel	Valve timing without valve clearance adjusted	Calage distribution sans jeu aux culbuteurs réglé	Fasatura senza gioco delle punterie e delle aste
Einlaß öffnet vor OT  Grad	Inlet opens before TDC  degrees	Admission ouvre avant PMH  degrés	Valvola aspirazione apre prima del PMS  Gradi
Einlaß schließt nach UT  Grad	Inlet closes after BDC  degrees	Admission ferme après PMB  degrés	Valvola aspirazione chiude dopo il PMI  Gradi
Auslaß öffnet vor UT  Grad	Exhaust opens before BDC  degrees	Echappement ouvre avant PMB  degrés	Valvola scarico apre prima del PMI  Gradi
Auslaß schließt nach OT  Grad	Exhaust closes after TDC  degrees	Echappement ferme après PMH  degrés	Valvola scarico chiude dopo il PMS  Gradi
Absteuerventil  bar	Pressurestat  bar	Clapet régulateur final  bars	Valvola di regolazione pressione olio  bar
Schmieröldruck in niedrigem Leerlauf Temperatur ca. 120 °C Öl SAE 15W/40  Minimum bar	Lube oil pressure at low idling Temperature approx. 120 °C oil SAE 15W/40  min. bar	Pression d'huile au bas ralent température ca. 120 °C huile SAE 15W/40  mini bars	Pressione olio con motore al minimo, temp. olio circa 120 °C, olio SAE 15W/40  minima bar

Werkstatthandbuch BFM 1012/E, BFM 1013/E

BF4M 1012 BF4M 1013	BF4M 1012 E BF4M 1013 E	BF6M 1012 BF6M 1013	BF6M 1012 E BF6M 1013 E
		46 46,5	BFM 1012/ E BFM 1013/ E
		56 55,5	BFM 1012/ E BFM 1013/ E
		96 100,5	BFM 1012/ E BFM 1013/ E
		50 51,5	BFM 1012/ E BFM 1013/ E
	6 ± 0,75		10 ± 1
		0,8	







**Ventilspieleinstellschema**  
**Schematic for valve clearance adjustment**  
**Schéma de réglage des soupapes**  
**Schema di regolazione del gioco delle valvole**

Werkstatthandbuch BFM 1012/E, BFM 1013/E

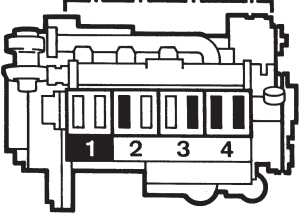
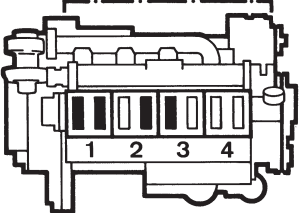
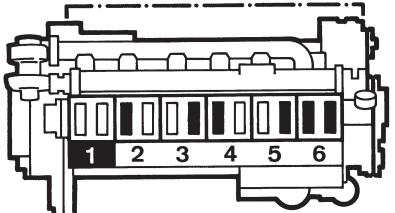
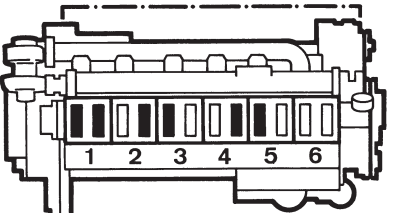
1	2
<p><b>Kurbelwellenstellung</b></p> <p>Motor bis zum Erreichen der Ventilüberschneidung am Zyl. Nr. 1 durchdrehen.</p>	<p><b>Kurbelwellenstellung</b></p> <p>Motor um eine volle Umdrehung (360°) weiterdrehen.</p>
<p>nicht einstellbar</p> 	<p>einstellbar</p> 
	





English	Français	Italiano
<p><b>Crankshaft position 1</b></p> <p>Turn engine until valves of cylinder No. 1 overlap.</p> <p>Not ready for adjustment.</p>	<p><b>Position de l'arbre à cames 1</b></p> <p>Virer le moteur jusqu'au chevauchement des soupapes au cylindre 1.</p> <p>non réglable</p>	<p><b>Posizione dell'albero a gomiti 1</b></p> <p>Virare il motore nel suo senso di rotazione fino a portare le valvole del cilindro nr. 1 nella posizione di sovrapposizione.</p> <p>La regolazione non è effettuabile.</p>
<p><b>Crankshaft position 2:</b></p> <p>Turn engine further by one complete revolution (360°).</p> <p>Ready for adjustment.</p>	<p><b>Position de l'arbre à cames 2</b></p> <p>Tourner le moteur d'un tour complet (360°)</p> <p>réglable</p>	<p><b>Posizione dell'albero a gomiti 2</b></p> <p>Virare il motore nel suo senso di rotazione di un giro completo, cioè per ulteriori 360°.</p> <p>La regolazione è effettuabile.</p>

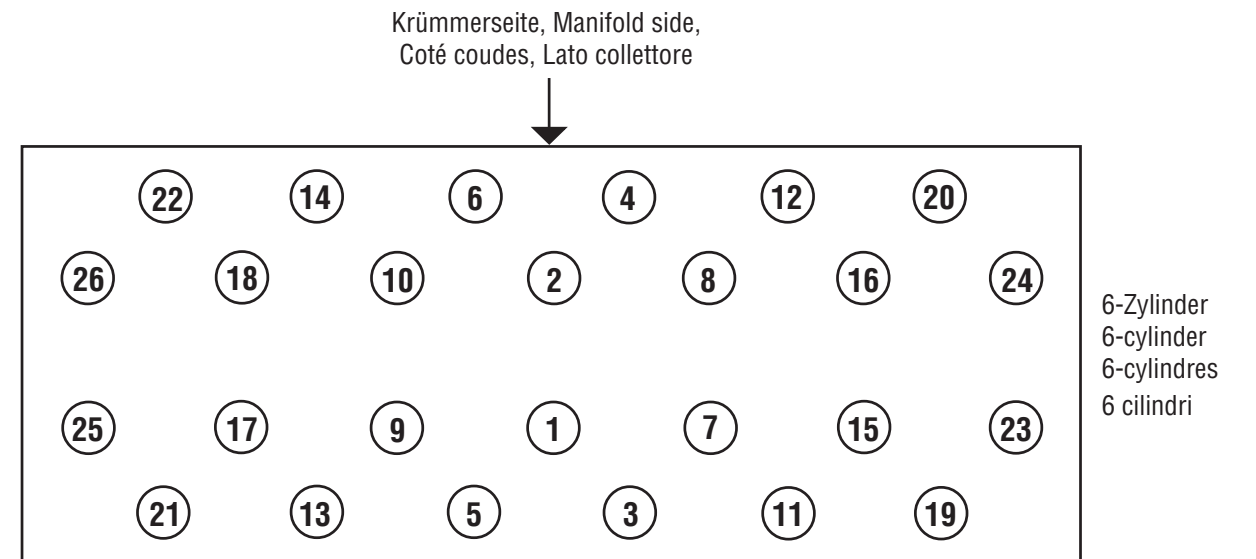
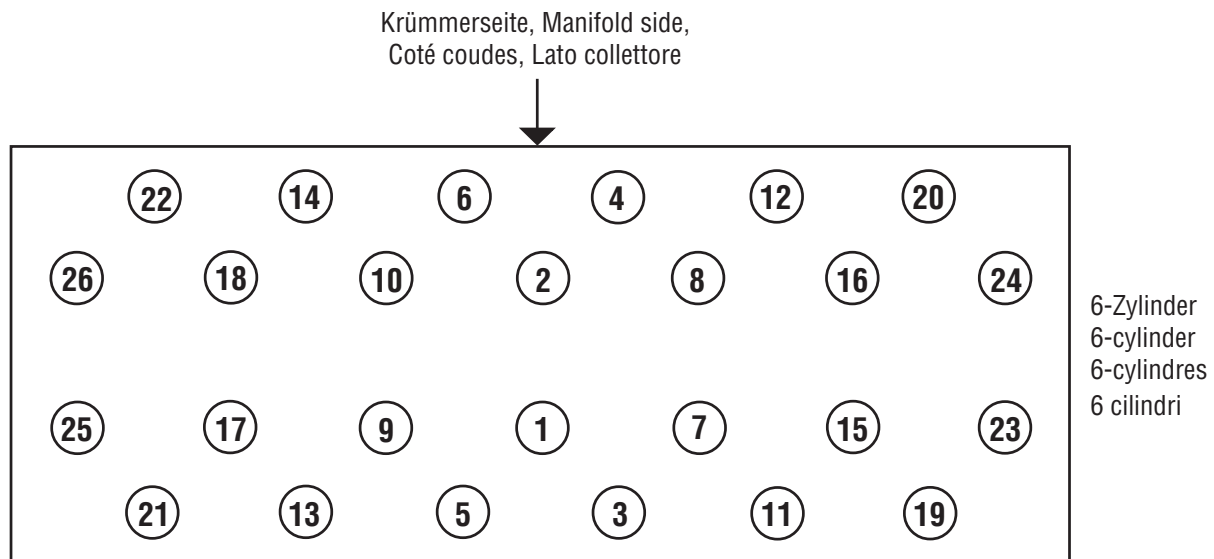
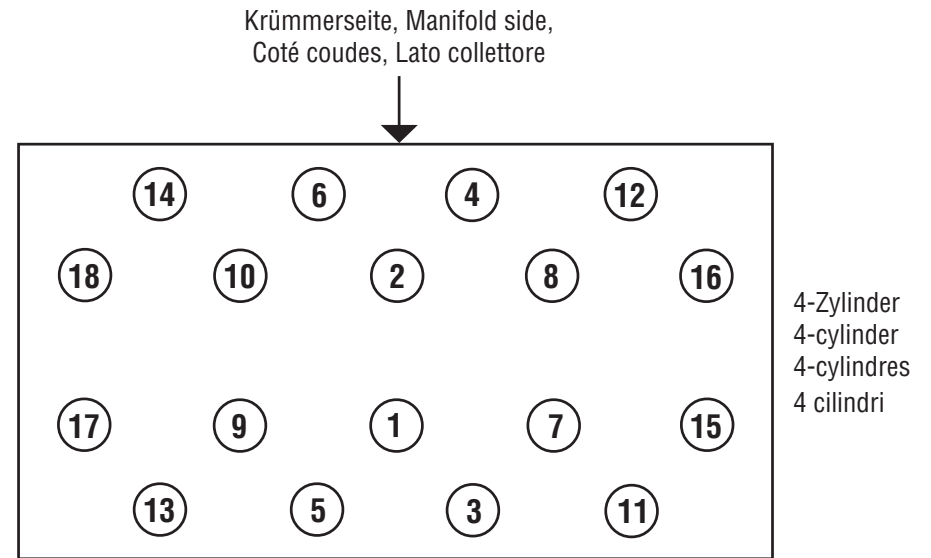
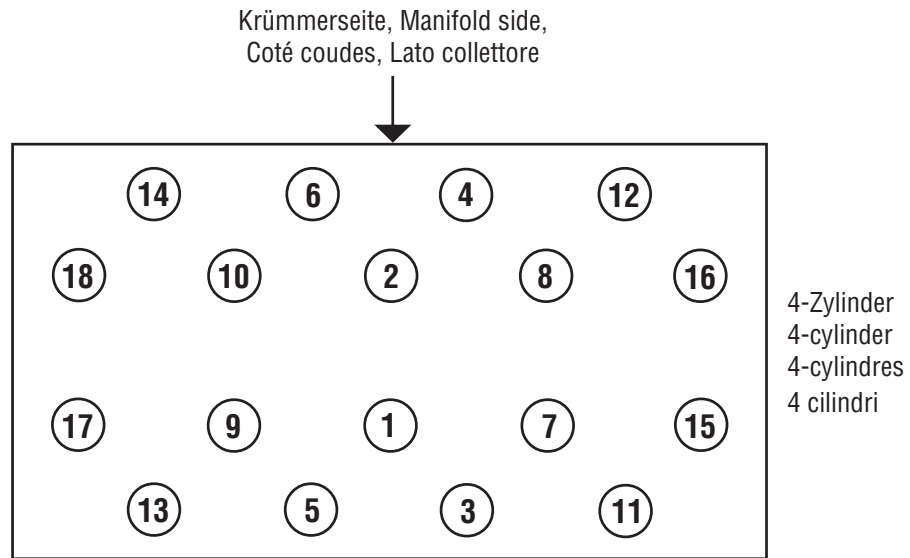
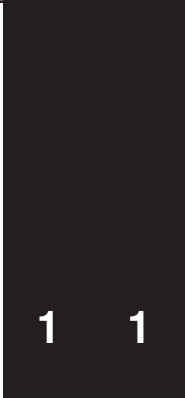

Reihenfolge beim Anziehen der Zylinderkopfschrauben  
 Tightening order for cylinder head bolts  
 Ordre à respecter lors du serrage d'approche et définitif des vis de cul.  
 Sequenza di serraggio delle viti delle teste dei cilindri

Werkstatthandbuch BFM 1012/E, BFM 1013/E



Mot. - Typ	Code	Mot. - Nr.	kW(G) red.	EP	K	E <input type="checkbox"/>	<input type="text"/>	<input type="text"/>	0122 3237
<input type="text"/>	<input type="text"/>	<input type="text"/>	<input type="text"/>	<input type="text"/>	<input type="text"/>		<input type="text"/>	<input type="text"/>	
	kW(S)	1/min	←°	kW(S) red.			<input type="text"/>	<input type="text"/>	
	<input type="text"/>	<input type="text"/>	<input type="text"/>	<input type="text"/>			<input type="text"/>	<input type="text"/>	
	kW(W)			°C			<input type="text"/>	<input type="text"/>	
	<input type="text"/>	<input type="text"/>	<input type="text"/>	m			<input type="text"/>	<input type="text"/>	
	DEUTZ AG	MADE IN GERMANY							

**Hinweis:**

Ab 07.1996 ist auf dem Schriftfeld für den Förderbeginn auch der Nockenwellentyp A, B oder C angegeben. Dies ist bei der Grundeinstellung der Einspritzpumpen, siehe Tabelle 1, unbedingt zu berücksichtigen.

**Note:**

As of July 1996, camshaft type A, B or C will also be indicated in the inscription field for the commencement of delivery. It is absolutely necessary to consider this when determining the standard dimension of the injection pumps, see table 1.

**Nota:**

A compter de 07/1996 le cadre d'identification réservé au début d'injection indiquera également le type d'arbre à cames A, B ou C. Prière de respecter impérativement cette indication lors du calagne des pompes d'injection, voir tableau 1.

**Nota:**

A partire dal mese di luglio 1996, nel riquadro per l'inizio di mandata è riportato pure il tipo di albero a camme (A, B o C). Di tale dato si deve assolutamente tener conto all'atto della messa a punto di base delle pompe di iniezione, vedi tabella 1.







# Ausgleichscheibendicke für Förderbeginn ermitteln. Bosch Einspritzpumpe

Tabelle 1

Motortyp	Förderbeginn (FB) Nenn./Tol. (° kW v. OT)	Nockenwelle Typ	Vorhub (Vh) Nennwert (mm)	Vorhub Korrekturfaktor (mm/° kW)	Grundmaß E-Pumpe (Lo) (mm)
BFM 1012	6	C	5,16	0,1	109 / 119
BFM 1012	7	C	4,98	0,1	109 / 119
BFM 1012	8	C	4,80	0,1	109 / 119
BFM 1012/ C	9	C	4,63	0,1	109 / 119
BFM 1012/ C	10	C	4,47	0,1	109 / 119
BFM 1012/ C	11	C	4,30	0,1	109 / 119
BFM 1012	12	C	4,14	0,1	109 / 119
BFM 1012	13	C	4,00	0,1	109 / 119
BFM 1013	5	A	6,32	0,1	143
BFM 1013	6	A	6,11	0,1	143
BFM 1013	7	A	5,90	0,1	143
BFM 1013	8	A	5,70	0,1	143
BFM 1013/ C	9	A	5,50	0,1	143
BFM 1013	10	A	5,31	0,1	143
BFM 1013	4	B	5,70	0,1	143
BFM 1013	4,5	B	5,60	0,1	143
BFM 1013	5	B	5,50	0,1	143
BFM 1013	5,5	B	5,40	0,1	143
BFM 1013	6	B	5,31	0,1	143
BFM 1013	7	B	5,10	0,1	143

Tabelle 2

Theor. Dicke "T <sub>s</sub> " (mm)	Ausgleichscheibendicke "S <sub>s</sub> " (mm)	Theor. Dicke "T <sub>s</sub> " (mm)	Ausgleichscheibendicke "S <sub>s</sub> " (mm)
0,95 - 1,049	1,0	2,45 - 2,549	2,5
1,05 - 1,149	1,1	2,55 - 2,649	2,6
1,15 - 1,249	1,2	2,65 - 2,749	2,7
1,25 - 1,349	1,3	2,75 - 2,849	2,8
1,35 - 1,449	1,4	2,85 - 2,949	2,9
1,45 - 1,549	1,5	2,95 - 3,049	3,0
1,55 - 1,649	1,6	3,05 - 3,149	3,1
1,65 - 1,749	1,7	3,15 - 3,249	3,2
1,75 - 1,849	1,8	3,25 - 3,349	3,3
1,85 - 1,949	1,9	3,35 - 3,449	3,4
1,95 - 2,049	2,0	3,45 - 3,549	3,5
2,05 - 2,149	2,1	3,55 - 3,649	3,6
2,15 - 2,249	2,2	3,65 - 3,749	3,7
2,25 - 2,349	2,3		
2,35 - 2,449	2,4		

1 1

Tabelle 1

Motortyp	Förderbeginn (FB) Nenn./Tol. (° kW v. OT)	Nockenwelle Typ	Vorhub (Vh) Nennwert (mm)	Vorhub Korrekturfaktor (mm/° kW)	Grundmaß E-Pumpe (Lo) (mm)
BFM 1012	6	C	5,16	0,1	109 / 119
BFM 1012	7	C	4,98	0,1	109 / 119
BFM 1012	8	C	4,80	0,1	109 / 119
BFM 1012/ C	9	C	4,63	0,1	109 / 119
BFM 1012/ C	10	C	4,47	0,1	109 / 119
BFM 1012/ C	11	C	4,30	0,1	109 / 119
BFM 1012	12	C	4,14	0,1	109 / 119
BFM 1012	13	C	4,00	0,1	109 / 119
BFM 1013	5	A	6,32	0,1	143
BFM 1013	6	A	6,11	0,1	143
BFM 1013	7	A	5,90	0,1	143
BFM 1013	8	A	5,70	0,1	143
BFM 1013/ C	9	A	5,50	0,1	143
BFM 1013	10	A	5,31	0,1	143
BFM 1013	4	B	5,70	0,1	143
BFM 1013	4,5	B	5,60	0,1	143
BFM 1013	5	B	5,50	0,1	143
BFM 1013	5,5	B	5,40	0,1	143
BFM 1013	6	B	5,31	0,1	143
BFM 1013	7	B	5,10	0,1	143

Tabelle 2

Theor. Dicke "T <sub>s</sub> " (mm)	Ausgleichscheibendicke "S <sub>s</sub> " (mm)	Theor. Dicke "T <sub>s</sub> " (mm)	Ausgleichscheibendicke "S <sub>s</sub> " (mm)
0,95 - 1,049	1,0	2,45 - 2,549	2,5
1,05 - 1,149	1,1	2,55 - 2,649	2,6
1,15 - 1,249	1,2	2,65 - 2,749	2,7
1,25 - 1,349	1,3	2,75 - 2,849	2,8
1,35 - 1,449	1,4	2,85 - 2,949	2,9
1,45 - 1,549	1,5	2,95 - 3,049	3,0
1,55 - 1,649	1,6	3,05 - 3,149	3,1
1,65 - 1,749	1,7	3,15 - 3,249	3,2
1,75 - 1,849	1,8	3,25 - 3,349	3,3
1,85 - 1,949	1,9	3,35 - 3,449	3,4
1,95 - 2,049	2,0	3,45 - 3,549	3,5
2,05 - 2,149	2,1	3,55 - 3,649	3,6
2,15 - 2,249	2,2	3,65 - 3,749	3,7
2,25 - 2,349	2,3		
2,35 - 2,449	2,4		

Berechnungsbeispiel:

BFM 1012

BFM 1013

Zylinder Nr.	0	0	1	2	0	1	2	3
E - Pumpen Nr.	xxx	xxx			xxx			
FB Ist gemessen °kW	8	8			10			
FB Nenn aus Tabelle 1 °kW	9	9			10			
Vh Korr.faktor aus Tab. 1 mm/°kW	0,1	0,1			0,1			
Vh Nenn aus Tabelle 1 mm	4,63	4,63			5,31			
Lo aus Tabelle 1 mm	<b>109</b>	<b>119</b>			<b>143</b>			
A/100 von E.-Pumpe mm	0,53	0,22			1,33			
L gemessen mm	116,26	126,57			152,22			
E1 = FB Ist - FB Nenn °kW	-1	-1			0			
E2 = E1 x Vh Korrekturfaktor mm	-0,1	-0,1			0			
E3 = E2 + Vh Nenn mm	4,53	4,53			5,31			
E4 = E3 + L 0 mm	113,53	123,53			148,31			
E5 = E4 + A/100 mm	114,06	123,75			149,64			
Ts = L - E5 mm	2,20	2,82			2,58			
"Ss" aus Tabelle 2 mm	<b>2,2</b>	<b>2,8</b>			<b>2,6</b>			

Berechnungsbeispiel:

BFM 1012

BFM 1013

Zylinder Nr.	0	0	1	2	0	1	2	3
E - Pumpen Nr.	xxx	xxx			xxx			
FB Ist gemessen °kW	8	8			10			
FB Nenn aus Tabelle 1 °kW	9	9			10			
Vh Korr.faktor aus Tab. 1 mm/°kW	0,1	0,1			0,1			
Vh Nenn aus Tabelle 1 mm	4,63	4,63			5,31			
Lo aus Tabelle 1 mm	<b>109</b>	<b>119</b>			<b>143</b>			
A/100 von E.-Pumpe mm	0,53	0,22			1,33			
L gemessen mm	116,26	126,57			152,22			
E1 = FB Ist - FB Nenn °kW	-1	-1			0			
E2 = E1 x Vh Korrekturfaktor mm	-0,1	-0,1			0			
E3 = E2 + Vh Nenn mm	4,53	4,53			5,31			
E4 = E3 + L 0 mm	113,53	123,53			148,31			
E5 = E4 + A/100 mm	114,06	123,75			149,64			
Ts = L - E5 mm	2,20	2,82			2,58			
"Ss" aus Tabelle 2 mm	<b>2,2</b>	<b>2,8</b>			<b>2,6</b>			





**Determining shim thickness for commencement of delivery.  
Bosch injection pump**

**Table 1**

Engine type	Commencement of delivery (FB) (° C/A BTDC)	Camshaft type	Pre-stroke (Vh) Nom. value (mm)	Pre-stroke correction factor (mm/° C/A)	Standard dimensions inj. pump (Lo) (mm)
BFM 1012	6	C	5,16	0,1	109 / 119
BFM 1012	7	C	4,98	0,1	109 / 119
BFM 1012	8	C	4,80	0,1	109 / 119
BFM 1012/ C	9	C	4,63	0,1	109 / 119
BFM 1012/ C	10	C	4,47	0,1	109 / 119
BFM 1012/ C	11	C	4,30	0,1	109 / 119
BFM 1012	12	C	4,14	0,1	109 / 119
BFM 1012	13	C	4,00	0,1	109 / 119
BFM 1013	5	A	6,32	0,1	143
BFM 1013	6	A	6,11	0,1	143
BFM 1013	7	A	5,90	0,1	143
BFM 1013	8	A	5,70	0,1	143
BFM 1013/ C	9	A	5,50	0,1	143
BFM 1013	10	A	5,31	0,1	143
BFM 1013	4	B	5,70	0,1	143
BFM 1013	4,5	B	5,60	0,1	143
BFM 1013	5	B	5,50	0,1	143
BFM 1013	5,5	B	5,40	0,1	143
BFM 1013	6	B	5,31	0,1	143
BFM 1013	7	B	5,10	0,1	143

**Table 2**

Theor. thickness "Ts" (mm)	Shim-thickness "Ss" (mm)	Theor. thickness "Ts" (mm)	Shim-thickness "Ss" (mm)
0,95 - 1,049	1,0	2,45 - 2,549	2,5
1,05 - 1,149	1,1	2,55 - 2,649	2,6
1,15 - 1,249	1,2	2,65 - 2,749	2,7
1,25 - 1,349	1,3	2,75 - 2,849	2,8
1,35 - 1,449	1,4	2,85 - 2,949	2,9
1,45 - 1,549	1,5	2,95 - 3,049	3,0
1,55 - 1,649	1,6	3,05 - 3,149	3,1
1,65 - 1,749	1,7	3,15 - 3,249	3,2
1,75 - 1,849	1,8	3,25 - 3,349	3,3
1,85 - 1,949	1,9	3,35 - 3,449	3,4
1,95 - 2,049	2,0	3,45 - 3,549	3,5
2,05 - 2,149	2,1	3,55 - 3,649	3,6
2,15 - 2,249	2,2	3,65 - 3,749	3,7
2,25 - 2,349	2,3		
2,35 - 2,449	2,4		

1 1

**Table 1**

Engine type	Commencement of delivery (FB) (° C/A BTDC)	Camshaft type	Pre-stroke (Vh) Nom. value (mm)	Pre-stroke correction factor (mm/° C/A)	Standard dimensions inj. pump (Lo) (mm)
BFM 1012	6	C	5,16	0,1	109 / 119
BFM 1012	7	C	4,98	0,1	109 / 119
BFM 1012	8	C	4,80	0,1	109 / 119
BFM 1012/ C	9	C	4,63	0,1	109 / 119
BFM 1012/ C	10	C	4,47	0,1	109 / 119
BFM 1012/ C	11	C	4,30	0,1	109 / 119
BFM 1012	12	C	4,14	0,1	109 / 119
BFM 1012	13	C	4,00	0,1	109 / 119
BFM 1013	5	A	6,32	0,1	143
BFM 1013	6	A	6,11	0,1	143
BFM 1013	7	A	5,90	0,1	143
BFM 1013	8	A	5,70	0,1	143
BFM 1013/ C	9	A	5,50	0,1	143
BFM 1013	10	A	5,31	0,1	143
BFM 1013	4	B	5,70	0,1	143
BFM 1013	4,5	B	5,60	0,1	143
BFM 1013	5	B	5,50	0,1	143
BFM 1013	5,5	B	5,40	0,1	143
BFM 1013	6	B	5,31	0,1	143
BFM 1013	7	B	5,10	0,1	143

**Table 2**

Theor. thickness "Ts" (mm)	Shim-thickness "Ss" (mm)	Theor. thickness "Ts" (mm)	Shim-thickness "Ss" (mm)
0,95 - 1,049	1,0	2,45 - 2,549	2,5
1,05 - 1,149	1,1	2,55 - 2,649	2,6
1,15 - 1,249	1,2	2,65 - 2,749	2,7
1,25 - 1,349	1,3	2,75 - 2,849	2,8
1,35 - 1,449	1,4	2,85 - 2,949	2,9
1,45 - 1,549	1,5	2,95 - 3,049	3,0
1,55 - 1,649	1,6	3,05 - 3,149	3,1
1,65 - 1,749	1,7	3,15 - 3,249	3,2
1,75 - 1,849	1,8	3,25 - 3,349	3,3
1,85 - 1,949	1,9	3,35 - 3,449	3,4
1,95 - 2,049	2,0	3,45 - 3,549	3,5
2,05 - 2,149	2,1	3,55 - 3,649	3,6
2,15 - 2,249	2,2	3,65 - 3,749	3,7
2,25 - 2,349	2,3		
2,35 - 2,449	2,4		

Calculation example:

**BFM 1012**

**BFM 1013**

Cylinder No.	0	0	1	2	0	1	2	3
Injection pump No.	xxx	xxx			xxx			
FB measured °C/A	8	8			10			
FB nom. from table 1 °C/A	9	9			10			
Vh corr. factor from table 1 mm/°C/A	0.1	0.1			0.1			
Vh nom. from table 1 mm	4.63	4.63			5.31			
L0 nom. from table 1 mm	<b>109</b>	<b>119</b>			<b>143</b>			
A/100 of inj. pump mm	0.53	0.22			1.33			
L measured mm	116.26	126.57			152.22			
E1 = FB act. - FB nom °C/A	-1	-1			0			
E2 = E1 x Vh corr. factor mm	-0.1	-0.1			0			
E3 = E2 + Vh nom. mm	4.53	4.53			5.31			
E4 = E3 + L 0 mm	113.53	123.53			148.31			
E5 = E4 + A/100 mm	114.06	123.75			149.64			
Ts = L - E5 mm	2.20	2.82			2.58			
"Ss" from table 2 mm	<b>2.2</b>	<b>2.8</b>			<b>2.6</b>			

Calculation example:

**BFM 1012**

**BFM 1013**

Cylinder No.	0	0	1	2	0	1	2	3
Injection pump No.	xxx	xxx			xxx			
FB measured °C/A	8	8			10			
FB nom. from table 1 °C/A	9	9			10			
Vh corr. factor from table 1 mm/°C/A	0.1	0.1			0.1			
Vh nom. from table 1 mm	4.63	4.63			5.31			
L0 nom. from table 1 mm	<b>109</b>	<b>119</b>			<b>143</b>			
A/100 of inj. pump mm	0.53	0.22			1.33			
L measured mm	116.26	126.57			152.22			
E1 = FB act. - FB nom °C/A	-1	-1			0			
E2 = E1 x Vh corr. factor mm	-0.1	-0.1			0			
E3 = E2 + Vh nom. mm	4.53	4.53			5.31			
E4 = E3 + L 0 mm	113.53	123.53			148.31			
E5 = E4 + A/100 mm	114.06	123.75			149.64			
Ts = L - E5 mm	2.20	2.82			2.58			
"Ss" from table 2 mm	<b>2.2</b>	<b>2.8</b>			<b>2.6</b>			



# Calcul de l'épaisseur des rondelles d'épaisseur pour le début d'injection. Pompe d'injection Bosch

Tableau 1

Type de moteur	Début d'injection (FB) nomin./tol. (° vil. av. PMH)	Arbre à cames type	Précourse (Vh) valeur nomin. (mm)	Course à Facteur de correction (mm/° vil.)	Cote de base Ppe d'inject. (Lo) (mm)
BFM 1012	6	C	5,16	0,1	109 / 119
BFM 1012	7	C	4,98	0,1	109 / 119
BFM 1012	8	C	4,80	0,1	109 / 119
BFM 1012/ C	9	C	4,63	0,1	109 / 119
BFM 1012/ C	10	C	4,47	0,1	109 / 119
BFM 1012/ C	11	C	4,30	0,1	109 / 119
BFM 1012	12	C	4,14	0,1	109 / 119
BFM 1012	13	C	4,00	0,1	109 / 119
BFM 1013	5	A	6,32	0,1	143
BFM 1013	6	A	6,11	0,1	143
BFM 1013	7	A	5,90	0,1	143
BFM 1013	8	A	5,70	0,1	143
BFM 1013/ C	9	A	5,50	0,1	143
BFM 1013	10	A	5,31	0,1	143
BFM 1013	4	B	5,70	0,1	143
BFM 1013	4,5	B	5,60	0,1	143
BFM 1013	5	B	5,50	0,1	143
BFM 1013	5,5	B	5,40	0,1	143
BFM 1013	6	B	5,31	0,1	143
BFM 1013	7	B	5,10	0,1	143

Tableau 2

Epaisseur théorique "Ts" (mm)	Epaisseur rondelles-d'épaisseur "Ss" (mm)	Epaisseur théorique "Ts" (mm)	Epaisseur rondelles-d'épaisseur "Ss" (mm)
0,95 - 1,049	1,0	2,45 - 2,549	2,5
1,05 - 1,149	1,1	2,55 - 2,649	2,6
1,15 - 1,249	1,2	2,65 - 2,749	2,7
1,25 - 1,349	1,3	2,75 - 2,849	2,8
1,35 - 1,449	1,4	2,85 - 2,949	2,9
1,45 - 1,549	1,5	2,95 - 3,049	3,0
1,55 - 1,649	1,6	3,05 - 3,149	3,1
1,65 - 1,749	1,7	3,15 - 3,249	3,2
1,75 - 1,849	1,8	3,25 - 3,349	3,3
1,85 - 1,949	1,9	3,35 - 3,449	3,4
1,95 - 2,049	2,0	3,45 - 3,549	3,5
2,05 - 2,149	2,1	3,55 - 3,649	3,6
2,15 - 2,249	2,2	3,65 - 3,749	3,7
2,25 - 2,349	2,3		
2,35 - 2,449	2,4		

1 1

Tableau 1

Type de moteur	Début d'injection (FB) nomin./tol. (° vil. av. PMH)	Arbre à cames type	Précourse (Vh) valeur nomin. (mm)	Course à Facteur de correction (mm/° vil.)	Cote de base Ppe d'inject. (Lo) (mm)
BFM 1012	6	C	5,16	0,1	109 / 119
BFM 1012	7	C	4,98	0,1	109 / 119
BFM 1012	8	C	4,80	0,1	109 / 119
BFM 1012/ C	9	C	4,63	0,1	109 / 119
BFM 1012/ C	10	C	4,47	0,1	109 / 119
BFM 1012/ C	11	C	4,30	0,1	109 / 119
BFM 1012	12	C	4,14	0,1	109 / 119
BFM 1012	13	C	4,00	0,1	109 / 119
BFM 1013	5	A	6,32	0,1	143
BFM 1013	6	A	6,11	0,1	143
BFM 1013	7	A	5,90	0,1	143
BFM 1013	8	A	5,70	0,1	143
BFM 1013/ C	9	A	5,50	0,1	143
BFM 1013	10	A	5,31	0,1	143
BFM 1013	4	B	5,70	0,1	143
BFM 1013	4,5	B	5,60	0,1	143
BFM 1013	5	B	5,50	0,1	143
BFM 1013	5,5	B	5,40	0,1	143
BFM 1013	6	B	5,31	0,1	143
BFM 1013	7	B	5,10	0,1	143

Tableau 2

Epaisseur théorique "Ts" (mm)	Epaisseur rondelles-d'épaisseur "Ss" (mm)	Epaisseur théorique "Ts" (mm)	Epaisseur rondelles-d'épaisseur "Ss" (mm)
0,95 - 1,049	1,0	2,45 - 2,549	2,5
1,05 - 1,149	1,1	2,55 - 2,649	2,6
1,15 - 1,249	1,2	2,65 - 2,749	2,7
1,25 - 1,349	1,3	2,75 - 2,849	2,8
1,35 - 1,449	1,4	2,85 - 2,949	2,9
1,45 - 1,549	1,5	2,95 - 3,049	3,0
1,55 - 1,649	1,6	3,05 - 3,149	3,1
1,65 - 1,749	1,7	3,15 - 3,249	3,2
1,75 - 1,849	1,8	3,25 - 3,349	3,3
1,85 - 1,949	1,9	3,35 - 3,449	3,4
1,95 - 2,049	2,0	3,45 - 3,549	3,5
2,05 - 2,149	2,1	3,55 - 3,649	3,6
2,15 - 2,249	2,2	3,65 - 3,749	3,7
2,25 - 2,349	2,3		
2,35 - 2,449	2,4		

Exemple de calcul:

BFM 1012

BFM 1013

Cylindre no.	0	0	1	2	0	1	2	3
Pompe no.	xxx	xxx			xxx			
FB Début d'injection mesuré °vil	8	8			10			
FB Début d'injection nominal tableau 1 °vil	9	9			10			
Facteur de correction Vh tableau 1 mm/°vil	0,1	0,1			0,1			
Vh nominal tableau 1 mm	4,63	4,63			5,31			
L0 tableau 1 mm	<b>109</b>	<b>119</b>			<b>143</b>			
A/100 de pompe d'injection mm	0,53	0,22			1,33			
L mesuré mm	116,26	126,57			152,22			
E1 = FB réel - FB nomin. °vil.	-1	-1			0			
E2 = E1 x Vh facteur de correction mm	-0,1	-0,1			0			
E3 = E2 + Vh nomin. mm	4,53	4,53			5,31			
E4 = E3 + L 0 mm	113,53	123,53			148,31			
E5 = E4 + A/100 mm	114,06	123,75			149,64			
Ts = L - E5 mm	2,20	2,82			2,58			
"Ss" tableau 2 mm	<b>2,2</b>	<b>2,8</b>			<b>2,6</b>			

Exemple de calcul:

BFM 1012

BFM 1013

Cylindre no.	0	0	1	2	0	1	2	3
Pompe no.	xxx	xxx			xxx			
FB Début d'injection mesuré °vil	8	8			10			
FB Début d'injection nominal tableau 1 °vil	9	9			10			
Facteur de correction Vh tableau 1 mm/°vil	0,1	0,1			0,1			
Vh nominal tableau 1 mm	4,63	4,63			5,31			
L0 tableau 1 mm	<b>109</b>	<b>119</b>			<b>143</b>			
A/100 de pompe d'injection mm	0,53	0,22			1,33			
L mesuré mm	116,26	126,57			152,22			
E1 = FB réel - FB nomin. °vil.	-1	-1			0			
E2 = E1 x Vh facteur de correction mm	-0,1	-0,1			0			
E3 = E2 + Vh nomin. mm	4,53	4,53			5,31			
E4 = E3 + L 0 mm	113,53	123,53			148,31			
E5 = E4 + A/100 mm	114,06	123,75			149,64			
Ts = L - E5 mm	2,20	2,82			2,58			
"Ss" tableau 2 mm	<b>2,2</b>	<b>2,8</b>			<b>2,6</b>			



**Determinazione dello spessore delle rondelle per l'inizio di mandata.  
Pompa d'iniezione Bosch**

**Tabella 1**

Tipo di motore	Inizio mandata (FB) Nomin./Toller (*alb. mot pr. PMS)	Albero a camme Tipo	Precorsa (Vh) Valore nom. (mm)	Precorsa Fattore di correzione (mm/°alb. mot)	Misura base pompa iniez. (Lo) (mm)
BFM 1012	6	C	5,16	0,1	109 / 119
BFM 1012	7	C	4,98	0,1	109 / 119
BFM 1012	8	C	4,80	0,1	109 / 119
BFM 1012/ C	9	C	4,63	0,1	109 / 119
BFM 1012/ C	10	C	4,47	0,1	109 / 119
BFM 1012/ C	11	C	4,30	0,1	109 / 119
BFM 1012	12	C	4,14	0,1	109 / 119
BFM 1012	13	C	4,00	0,1	109 / 119
BFM 1013	5	A	6,32	0,1	143
BFM 1013	6	A	6,11	0,1	143
BFM 1013	7	A	5,90	0,1	143
BFM 1013	8	A	5,70	0,1	143
BFM 1013/ C	9	A	5,50	0,1	143
BFM 1013	10	A	5,31	0,1	143
BFM 1013	4	B	5,70	0,1	143
BFM 1013	4,5	B	5,60	0,1	143
BFM 1013	5	B	5,50	0,1	143
BFM 1013	5,5	B	5,40	0,1	143
BFM 1013	6	B	5,31	0,1	143
BFM 1013	7	B	5,10	0,1	143

**Tabella 2**

Spessore teorico "Ts" (mm)	Spessore rondelle "Ts" (mm)	Spessore teorico "Ts" (mm)	Spessore rondelle "Ts" (mm)
0,95 - 1,049	1,0	2,45 - 2,549	2,5
1,05 - 1,149	1,1	2,55 - 2,649	2,6
1,15 - 1,249	1,2	2,65 - 2,749	2,7
1,25 - 1,349	1,3	2,75 - 2,849	2,8
1,35 - 1,449	1,4	2,85 - 2,949	2,9
1,45 - 1,549	1,5	2,95 - 3,049	3,0
1,55 - 1,649	1,6	3,05 - 3,149	3,1
1,65 - 1,749	1,7	3,15 - 3,249	3,2
1,75 - 1,849	1,8	3,25 - 3,349	3,3
1,85 - 1,949	1,9	3,35 - 3,449	3,4
1,95 - 2,049	2,0	3,45 - 3,549	3,5
2,05 - 2,149	2,1	3,55 - 3,649	3,6
2,15 - 2,249	2,2	3,65 - 3,749	3,7
2,25 - 2,349	2,3		
2,35 - 2,449	2,4		

1 1

**Tabella 1**

Tipo di motore	Inizio mandata (FB) Nomin./Toller (*alb. mot pr. PMS)	Albero a camme Tipo	Precorsa (Vh) Valore nom. (mm)	Precorsa Fattore di correzione (mm/°alb. mot)	Misura base pompa iniez. (Lo) (mm)
BFM 1012	6	C	5,16	0,1	109 / 119
BFM 1012	7	C	4,98	0,1	109 / 119
BFM 1012	8	C	4,80	0,1	109 / 119
BFM 1012/ C	9	C	4,63	0,1	109 / 119
BFM 1012/ C	10	C	4,47	0,1	109 / 119
BFM 1012/ C	11	C	4,30	0,1	109 / 119
BFM 1012	12	C	4,14	0,1	109 / 119
BFM 1012	13	C	4,00	0,1	109 / 119
BFM 1013	5	A	6,32	0,1	143
BFM 1013	6	A	6,11	0,1	143
BFM 1013	7	A	5,90	0,1	143
BFM 1013	8	A	5,70	0,1	143
BFM 1013/ C	9	A	5,50	0,1	143
BFM 1013	10	A	5,31	0,1	143
BFM 1013	4	B	5,70	0,1	143
BFM 1013	4,5	B	5,60	0,1	143
BFM 1013	5	B	5,50	0,1	143
BFM 1013	5,5	B	5,40	0,1	143
BFM 1013	6	B	5,31	0,1	143
BFM 1013	7	B	5,10	0,1	143

**Tabella 2**

Spessore teorico "Ts" (mm)	Spessore rondelle "Ts" (mm)	Spessore teorico "Ts" (mm)	Spessore rondelle "Ts" (mm)
0,95 - 1,049	1,0	2,45 - 2,549	2,5
1,05 - 1,149	1,1	2,55 - 2,649	2,6
1,15 - 1,249	1,2	2,65 - 2,749	2,7
1,25 - 1,349	1,3	2,75 - 2,849	2,8
1,35 - 1,449	1,4	2,85 - 2,949	2,9
1,45 - 1,549	1,5	2,95 - 3,049	3,0
1,55 - 1,649	1,6	3,05 - 3,149	3,1
1,65 - 1,749	1,7	3,15 - 3,249	3,2
1,75 - 1,849	1,8	3,25 - 3,349	3,3
1,85 - 1,949	1,9	3,35 - 3,449	3,4
1,95 - 2,049	2,0	3,45 - 3,549	3,5
2,05 - 2,149	2,1	3,55 - 3,649	3,6
2,15 - 2,249	2,2	3,65 - 3,749	3,7
2,25 - 2,349	2,3		
2,35 - 2,449	2,4		

**Esempio di calcolo**

**BFM 1012**

**BFM 1013**

Cilindro nr.	0	0	1	2	0	1	2	3
Pompe di iniezione nr.	xxx	xxx			xxx			
FB reale misurato °alb.mot.	8	8			10			
FB nom. da tab.1 °alb.mot.	9	9			10			
Fatt. corr. Vh da tab.1 mm/°alb.mot.	0,1	0,1			0,1			
Vh nom. da tabella 1 mm	4,63	4,63			5,31			
Lo da tabella 1 mm	<b>109</b>	<b>119</b>			<b>143</b>			
A/100 della pompa iniez. mm	0,53	0,22			1,33			
L misurata mm	116,26	126,57			152,22			
E1 = FB reale - FB nom °alb.mot.	-1	-1			0			
E2 = E1x fattore correz. Vh mm	-0,1	-0,1			0			
E3 = E2 + Vh Nominale mm	4,53	4,53			5,31			
E4 = E3 + L 0 mm	113,53	123,53			148,31			
E5 = E4 + A/100 mm	114,06	123,75			149,64			
Ts = L - E5 mm	2,20	2,82			2,58			
"Ss" da tabella 5 mm	<b>2,2</b>	<b>2,8</b>			<b>2,6</b>			

**Esempio di calcolo**

**BFM 1012**

**BFM 1013**

Cilindro nr.	0	0	1	2	0	1	2	3
Pompe di iniezione nr.	xxx	xxx			xxx			
FB reale misurato °alb.mot.	8	8			10			
FB nom. da tab.1 °alb.mot.	9	9			10			
Fatt. corr. Vh da tab.1 mm/°alb.mot.	0,1	0,1			0,1			
Vh nom. da tabella 1 mm	4,63	4,63			5,31			
Lo da tabella 1 mm	<b>109</b>	<b>119</b>			<b>143</b>			
A/100 della pompa iniez. mm	0,53	0,22			1,33			
L misurata mm	116,26	126,57			152,22			
E1 = FB reale - FB nom °alb.mot.	-1	-1			0			
E2 = E1x fattore correz. Vh mm	-0,1	-0,1			0			
E3 = E2 + Vh Nominale mm	4,53	4,53			5,31			
E4 = E3 + L 0 mm	113,53	123,53			148,31			
E5 = E4 + A/100 mm	114,06	123,75			149,64			
Ts = L - E5 mm	2,20	2,82			2,58			
"Ss" da tabella 5 mm	<b>2,2</b>	<b>2,8</b>			<b>2,6</b>			



# Ausgleichscheibendicke für Förderbeginn ermitteln bei BFM 1012 Bosch Einspritzpumpentausch im Servicefall. Grundmaß Lo = 109 mm

Die alte Einspritzpumpe und Ausgleichscheibe ist hierzu nicht erforderlich.

**Beispiel:** An einem BF6M1012 ist die Einspritzpumpe von Zylinder 3 zu ersetzen.

Vorgehensweise:

Vom Firmenschild in der Rubrik "EP" den EP-Code für Zylinder 3 ablesen, z.B. 070.  
(Lesefolge: Zeile 1 = Zyl.1, Zeile 2 = Zyl.2, u.s.w.)

The image shows a Deutz engine nameplate with various technical specifications. The EP code for cylinder 3 is highlighted as 070. The nameplate includes fields for Mot.-Typ, Code, Mot.-Nr., kW(G) red., kW(S) red., kW(W), 1/min, °C, m, and EP. The EP code is 070.

Korrigiertes Einspritzpumpeneinbaumaß ( $E_k$ ) aus Tabelle 3 entsprechend dem EP-Code entnehmen, z.B.111,725 mm.

**Tabelle 3**

$E_k$ (mm)	EP-Code	$E_k$ (mm)	EP-Code	$E_k$ (mm)	EP-Code	$E_k$ (mm)	EP-Code	$E_k$ (mm)	EP-Code
110,0		110,6		111,2	049	111,8	073	112,4	097
110,025		110,625		111,225	050	111,825	074	112,425	098
110,05		110,65		111,25	051	111,85	075	112,45	099
110,075		110,675		111,275	052	111,875	076	112,475	100
110,1		110,7		111,3	053	111,9	077	112,5	101
110,125		110,725		111,325	054	111,925	078	112,525	102
110,15		110,75	031	111,35	055	111,95	079	112,55	103
110,175		110,775	032	111,375	056	111,975	080	112,575	104
110,2		110,8	033	111,4	057	112,0	081	112,6	105
110,225		110,825	034	111,425	058	112,025	082	112,625	106
110,25		110,85	035	111,45	059	112,05	083	112,65	
110,275		110,875	036	111,475	060	112,075	084	112,675	
110,3		110,9	037	111,5	061	112,1	085	112,7	
110,325		110,925	038	111,525	062	112,125	086	112,725	
110,35		110,95	039	111,55	063	112,15	087	112,75	
110,375		110,975	040	111,575	064	112,175	088	112,775	
110,4		111,0	041	111,6	065	112,2	089	112,8	
110,425		111,025	042	111,625	066	112,225	090	112,825	
110,45		111,05	043	111,65	067	112,25	091	112,85	
110,475		111,075	044	111,675	068	112,275	092	112,875	
110,5		111,1	045	111,7	069	112,3	093	112,9	
110,525		111,125	046	111,725	070	112,325	094	112,925	
110,55		111,15	047	111,75	071	112,35	095	112,95	
110,575		111,175	048	111,775	072	112,375	096	112,975	

Kennzahl für Einspritzpumpenlänge (A) von der neuen Einspritzpumpe ablesen, z.B. 53.

Grundmaß der Einspritzpumpe ( $L_0$ ) aus Tabelle 1 entnehmen, z.B. 109 mm.

Theoretische Ausgleichscheibendicke ( $T_s$ ) ermitteln.

$$T_s = EK - (L_0 + A/100)$$

$$T_s = 111,725 \text{ mm} - (109 \text{ mm} + 53/100 \text{ mm})$$

$$T_s = 2,195 \text{ mm}$$

Ausgleichscheibendicke ( $S_s$ ) nach Tabelle 2 auswählen.

$$T_s 2,195 \text{ mm} = S_s \mathbf{2,2 \text{ mm}}$$

1 1

Die alte Einspritzpumpe und Ausgleichscheibe ist hierzu nicht erforderlich.

**Beispiel:** An einem BF6M1012 ist die Einspritzpumpe von Zylinder 3 zu ersetzen.

Vorgehensweise:

Vom Firmenschild in der Rubrik "EP" den EP-Code für Zylinder 3 ablesen, z.B. 070.  
(Lesefolge: Zeile 1 = Zyl.1, Zeile 2 = Zyl.2, u.s.w.)

The image shows a Deutz engine nameplate with various technical specifications. The EP code for cylinder 3 is highlighted as 070. The nameplate includes fields for Mot.-Typ, Code, Mot.-Nr., kW(G) red., kW(S) red., kW(W), 1/min, °C, m, and EP. The EP code is 070.

Korrigiertes Einspritzpumpeneinbaumaß ( $E_k$ ) aus Tabelle 3 entsprechend dem EP-Code entnehmen, z.B.111,725 mm.

**Tabelle 3**

$E_k$ (mm)	EP-Code	$E_k$ (mm)	EP-Code	$E_k$ (mm)	EP-Code	$E_k$ (mm)	EP-Code	$E_k$ (mm)	EP-Code
110,0		110,6		111,2	049	111,8	073	112,4	097
110,025		110,625		111,225	050	111,825	074	112,425	098
110,05		110,65		111,25	051	111,85	075	112,45	099
110,075		110,675		111,275	052	111,875	076	112,475	100
110,1		110,7		111,3	053	111,9	077	112,5	101
110,125		110,725		111,325	054	111,925	078	112,525	102
110,15		110,75	031	111,35	055	111,95	079	112,55	103
110,175		110,775	032	111,375	056	111,975	080	112,575	104
110,2		110,8	033	111,4	057	112,0	081	112,6	105
110,225		110,825	034	111,425	058	112,025	082	112,625	106
110,25		110,85	035	111,45	059	112,05	083	112,65	
110,275		110,875	036	111,475	060	112,075	084	112,675	
110,3		110,9	037	111,5	061	112,1	085	112,7	
110,325		110,925	038	111,525	062	112,125	086	112,725	
110,35		110,95	039	111,55	063	112,15	087	112,75	
110,375		110,975	040	111,575	064	112,175	088	112,775	
110,4		111,0	041	111,6	065	112,2	089	112,8	
110,425		111,025	042	111,625	066	112,225	090	112,825	
110,45		111,05	043	111,65	067	112,25	091	112,85	
110,475		111,075	044	111,675	068	112,275	092	112,875	
110,5		111,1	045	111,7	069	112,3	093	112,9	
110,525		111,125	046	111,725	070	112,325	094	112,925	
110,55		111,15	047	111,75	071	112,35	095	112,95	
110,575		111,175	048	111,775	072	112,375	096	112,975	

Kennzahl für Einspritzpumpenlänge (A) von der neuen Einspritzpumpe ablesen, z.B. 53.

Grundmaß der Einspritzpumpe ( $L_0$ ) aus Tabelle 1 entnehmen, z.B. 109 mm.

Theoretische Ausgleichscheibendicke ( $T_s$ ) ermitteln.

$$T_s = EK - (L_0 + A/100)$$

$$T_s = 111,725 \text{ mm} - (109 \text{ mm} + 53/100 \text{ mm})$$

$$T_s = 2,195 \text{ mm}$$

Ausgleichscheibendicke ( $S_s$ ) nach Tabelle 2 auswählen.

$$T_s 2,195 \text{ mm} = S_s \mathbf{2,2 \text{ mm}}$$





# Determining shim thickness for Bosch injection pump replacement on BFM 1012 in case of service. Standard dimensions $L_0 = 109$ mm

The old injection pump with shim is not required for such purpose.

**Example:** The injection pump of cylinder 3 is to be replaced on a BFM 1012 engine.

Procedure:

Read off EP code for cylinder 3 from nameplate under column „EP“, e.g. 070.  
(Reading sequence: line 1=cyl.1, line 2 = cyl.2, etc.)

The nameplate shows fields for Mot.-Typ, Code, Mot.-Nr., kW(G) red., EP, K, kW(S) red., kW(W), °C, and m. A circled 'E' is shown next to a grid of boxes. The EP code '070' is highlighted in the grid.

Take corrected injection pump installation dimension ( $E_k$ ) from table 3 according to EP code, e.g. 111.725 mm.

**Tabelle 3**

$E_k$ (mm)	EP code	$E_k$ (mm)	EP code	$E_k$ (mm)	EP code	$E_k$ (mm)	EP code	$E_k$ (mm)	EP code
110.0		110.6		111.2	049	111.8	073	112.4	097
110.025		110.625		111.225	050	111.825	074	112.425	098
110.05		110.65		111.25	051	111.85	075	112.45	099
110.075		110.675		111.275	052	111.875	076	112.475	100
110.1		110.7		111.3	053	111.9	077	112.5	101
110.125		110.725		111.325	054	111.925	078	112.525	102
110.15		110.75	031	111.35	055	111.95	079	112.55	103
110.175		110.775	032	111.375	056	111.975	080	112.575	104
110.2		110.8	033	111.4	057	112.0	081	112.6	105
110.225		110.825	034	111.425	058	112.025	082	112.625	106
110.25		110.85	035	111.45	059	112.05	083	112.65	
110.275		110.875	036	111.475	060	112.075	084	112.675	
110.3		110.9	037	111.5	061	112.1	085	112.7	
110.325		110.925	038	111.525	062	112.125	086	112.725	
110.35		110.95	039	111.55	063	112.15	087	112.75	
110.375		110.975	040	111.575	064	112.175	088	112.775	
110.4		111.0	041	111.6	065	112.2	089	112.8	
110.425		111.025	042	111.625	066	112.225	090	112.825	
110.45		111.05	043	111.65	067	112.25	091	112.85	
110.475		111.075	044	111.675	068	112.275	092	112.875	
110.5		111.1	045	111.7	069	112.3	093	112.9	
110.525		111.125	046	111.725	070	112.325	094	112.925	
110.55		111.15	047	111.75	071	112.35	095	112.95	
110.575		111.175	048	111.775	072	112.375	096	112.975	

Take code for injection pump length (A) from new injection pump, e.g. 53.

Take standard dimension of injection pump ( $L_0$ ) from table 1, e.g. 109 mm.

Determine theoretical shim thickness ( $T_s$ ).

$$T_s = E_k - (L_0 + A/100)$$

$$T_s = 111.725 \text{ mm} - (109 \text{ mm} + 53/100 \text{ mm})$$

$$T_s = 2.195 \text{ mm}$$

Select shim thickness ( $S_s$ ) according to table 2.

$$T_s 2.195 \text{ mm} = S_s \mathbf{2.2 \text{ mm}}$$



The old injection pump with shim is not required for such purpose.

**Example:** The injection pump of cylinder 3 is to be replaced on a BFM 1012 engine.

Procedure:

Read off EP code for cylinder 3 from nameplate under column „EP“, e.g. 070.  
(Reading sequence: line 1=cyl.1, line 2 = cyl.2, etc.)

The nameplate shows fields for Mot.-Typ, Code, Mot.-Nr., kW(G) red., EP, K, kW(S) red., kW(W), °C, and m. A circled 'E' is shown next to a grid of boxes. The EP code '070' is highlighted in the grid.

Take corrected injection pump installation dimension ( $E_k$ ) from table 3 according to EP code, e.g. 111.725 mm.

**Tabelle 3**

$E_k$ (mm)	EP code	$E_k$ (mm)	EP code	$E_k$ (mm)	EP code	$E_k$ (mm)	EP code	$E_k$ (mm)	EP code
110.0		110.6		111.2	049	111.8	073	112.4	097
110.025		110.625		111.225	050	111.825	074	112.425	098
110.05		110.65		111.25	051	111.85	075	112.45	099
110.075		110.675		111.275	052	111.875	076	112.475	100
110.1		110.7		111.3	053	111.9	077	112.5	101
110.125		110.725		111.325	054	111.925	078	112.525	102
110.15		110.75	031	111.35	055	111.95	079	112.55	103
110.175		110.775	032	111.375	056	111.975	080	112.575	104
110.2		110.8	033	111.4	057	112.0	081	112.6	105
110.225		110.825	034	111.425	058	112.025	082	112.625	106
110.25		110.85	035	111.45	059	112.05	083	112.65	
110.275		110.875	036	111.475	060	112.075	084	112.675	
110.3		110.9	037	111.5	061	112.1	085	112.7	
110.325		110.925	038	111.525	062	112.125	086	112.725	
110.35		110.95	039	111.55	063	112.15	087	112.75	
110.375		110.975	040	111.575	064	112.175	088	112.775	
110.4		111.0	041	111.6	065	112.2	089	112.8	
110.425		111.025	042	111.625	066	112.225	090	112.825	
110.45		111.05	043	111.65	067	112.25	091	112.85	
110.475		111.075	044	111.675	068	112.275	092	112.875	
110.5		111.1	045	111.7	069	112.3	093	112.9	
110.525		111.125	046	111.725	070	112.325	094	112.925	
110.55		111.15	047	111.75	071	112.35	095	112.95	
110.575		111.175	048	111.775	072	112.375	096	112.975	

Take code for injection pump length (A) from new injection pump, e.g. 53.

Take standard dimension of injection pump ( $L_0$ ) from table 1, e.g. 109 mm.

Determine theoretical shim thickness ( $T_s$ ).

$$T_s = E_k - (L_0 + A/100)$$

$$T_s = 111.725 \text{ mm} - (109 \text{ mm} + 53/100 \text{ mm})$$

$$T_s = 2.195 \text{ mm}$$

Select shim thickness ( $S_s$ ) according to table 2.

$$T_s 2.195 \text{ mm} = S_s \mathbf{2.2 \text{ mm}}$$



# Calcul de l'épaisseur des rondelles d'épaisseur pour le début d'injection pour remplacement de pompe d'injection Bosch BFM 1012 en intervention SAV. Cote de base Lo = 109 mm

L'ancienne pompe d'injection et la rondelle d'épaisseur ne sont pas nécessaires pour cela.

**Exemple :** remplacement de la pompe d'injection du cylindre 3 sur le BF6M 1012.

Procédure à suivre :

Lire sur la plaque d'identification du constructeur à la rubrique „EP“ le code EP pour le cylindre 3, exemple : 070, ensuite comme suit : ligne 1 = cyl. 1, ligne 2 = cyl. 2 etc.

Cote de montage corrigé de la pompe d'injection ( $E_k$ ) relevée dans le tableau 3 correspondant au code EP.  
Exemple 111,725 mm

**Tableau 3**

$E_k$ (mm)	Code EP	$E_k$ (mm)	Code EP	$E_k$ (mm)	Code EP	$E_k$ (mm)	Code EP	$E_k$ (mm)	Code EP
110,0		110,6		111,2	049	111,8	073	112,4	097
110,025		110,625		111,225	050	111,825	074	112,425	098
110,05		110,65		111,25	051	111,85	075	112,45	099
110,075		110,675		111,275	052	111,875	076	112,475	100
110,1		110,7		111,3	053	111,9	077	112,5	101
110,125		110,725		111,325	054	111,925	078	112,525	102
110,15		110,75	031	111,35	055	111,95	079	112,55	103
110,175		110,775	032	111,375	056	111,975	080	112,575	104
110,2		110,8	033	111,4	057	112,0	081	112,6	105
110,225		110,825	034	111,425	058	112,025	082	112,625	106
110,25		110,85	035	111,45	059	112,05	083	112,65	
110,275		110,875	036	111,475	060	112,075	084	112,675	
110,3		110,9	037	111,5	061	112,1	085	112,7	
110,325		110,925	038	111,525	062	112,125	086	112,725	
110,35		110,95	039	111,55	063	112,15	087	112,75	
110,375		110,975	040	111,575	064	112,175	088	112,775	
110,4		111,0	041	111,6	065	112,2	089	112,8	
110,425		111,025	042	111,625	066	112,225	090	112,825	
110,45		111,05	043	111,65	067	112,25	091	112,85	
110,475		111,075	044	111,675	068	112,275	092	112,875	
110,5		111,1	045	111,7	069	112,3	093	112,9	
110,525		111,125	046	111,725	070	112,325	094	112,925	
110,55		111,15	047	111,75	071	112,35	095	112,95	
110,575		111,175	048	111,775	072	112,375	096	112,975	

Consulter le tableau indiquant l'indice de longueur de la pompe d'injection (A) (nouvelle pompe d'injection), exemple 53.

La cote de base de la pompe d'injection ( $L_o$ ) est indiquée dans le tableau 1, exemple 109 mm.

Calculer l'épaisseur théorique ( $T_s$ ) des rondelles d'épaisseur

$$T_s = E_k - (L_o + A/100)$$

$$T_s = 111,725 \text{ mm} - (109 \text{ mm} + 53/100 \text{ mm})$$

$$T_s = 2,195 \text{ mm}$$

Choisir l'épaisseur des rondelles d'épaisseur ( $S_s$ ) selon le tableau 2

$$T_s 2,195 \text{ mm} = S_s \mathbf{2,2 \text{ mm}}$$

1 1

L'ancienne pompe d'injection et la rondelle d'épaisseur ne sont pas nécessaires pour cela.

**Exemple :** remplacement de la pompe d'injection du cylindre 3 sur le BF6M 1012.

Procédure à suivre :

Lire sur la plaque d'identification du constructeur à la rubrique „EP“ le code EP pour le cylindre 3, exemple : 070, ensuite comme suit : ligne 1 = cyl. 1, ligne 2 = cyl. 2 etc.

Cote de montage corrigé de la pompe d'injection ( $E_k$ ) relevée dans le tableau 3 correspondant au code EP.  
Exemple 111,725 mm

**Tableau 3**

$E_k$ (mm)	Code EP	$E_k$ (mm)	Code EP	$E_k$ (mm)	Code EP	$E_k$ (mm)	Code EP	$E_k$ (mm)	Code EP
110,0		110,6		111,2	049	111,8	073	112,4	097
110,025		110,625		111,225	050	111,825	074	112,425	098
110,05		110,65		111,25	051	111,85	075	112,45	099
110,075		110,675		111,275	052	111,875	076	112,475	100
110,1		110,7		111,3	053	111,9	077	112,5	101
110,125		110,725		111,325	054	111,925	078	112,525	102
110,15		110,75	031	111,35	055	111,95	079	112,55	103
110,175		110,775	032	111,375	056	111,975	080	112,575	104
110,2		110,8	033	111,4	057	112,0	081	112,6	105
110,225		110,825	034	111,425	058	112,025	082	112,625	106
110,25		110,85	035	111,45	059	112,05	083	112,65	
110,275		110,875	036	111,475	060	112,075	084	112,675	
110,3		110,9	037	111,5	061	112,1	085	112,7	
110,325		110,925	038	111,525	062	112,125	086	112,725	
110,35		110,95	039	111,55	063	112,15	087	112,75	
110,375		110,975	040	111,575	064	112,175	088	112,775	
110,4		111,0	041	111,6	065	112,2	089	112,8	
110,425		111,025	042	111,625	066	112,225	090	112,825	
110,45		111,05	043	111,65	067	112,25	091	112,85	
110,475		111,075	044	111,675	068	112,275	092	112,875	
110,5		111,1	045	111,7	069	112,3	093	112,9	
110,525		111,125	046	111,725	070	112,325	094	112,925	
110,55		111,15	047	111,75	071	112,35	095	112,95	
110,575		111,175	048	111,775	072	112,375	096	112,975	

Consulter le tableau indiquant l'indice de longueur de la pompe d'injection (A) (nouvelle pompe d'injection), exemple 53.

La cote de base de la pompe d'injection ( $L_o$ ) est indiquée dans le tableau 1, exemple 109 mm.

Calculer l'épaisseur théorique ( $T_s$ ) des rondelles d'épaisseur

$$T_s = E_k - (L_o + A/100)$$

$$T_s = 111,725 \text{ mm} - (109 \text{ mm} + 53/100 \text{ mm})$$

$$T_s = 2,195 \text{ mm}$$

Choisir l'épaisseur des rondelles d'épaisseur ( $S_s$ ) selon le tableau 2

$$T_s 2,195 \text{ mm} = S_s \mathbf{2,2 \text{ mm}}$$



**Determinazione dello spessore delle rondelle per l'inizio di mandata nel BFM 1012**  
**Sostituzione della pompa d'iniezione Bosch a cura del service.**  
**Misura base L<sub>0</sub> = 109 mm**

In tale caso non è necessario disporre né della vecchia pompa d'iniezione né del vecchio spessore.

**Esempio:** su un motore BF6M 1012 è necessario sostituire la pompa d'iniezione del cilindro 3.

Procedimento:

rilevare dalla targhetta motore nei riquadri "EP" il codice EP per il cilindro 3, per esempio 070.  
 (sistema di lettura: riquadro 1 = cilindro 1, riquadro 2 = cilindro 2, e così via)

Prendere nota dalla tabella 3 delle dimensioni d'ingombro corrette (E<sub>K</sub>) della pompa d'iniezione in corrispondenza al codice EP, nel nostro caso 111,725 mm.

**Tabella 3**

E <sub>K</sub> (mm)	Codice EP	E <sub>K</sub> (mm)	Codice EP	E <sub>K</sub> (mm)	Codice EP	E <sub>K</sub> (mm)	Codice EP	E <sub>K</sub> (mm)	Codice EP
110,0		110,6		111,2	049	111,8	073	112,4	097
110,025		110,625		111,225	050	111,825	074	112,425	098
110,05		110,65		111,25	051	111,85	075	112,45	099
110,075		110,675		111,275	052	111,875	076	112,475	100
110,1		110,7		111,3	053	111,9	077	112,5	101
110,125		110,725		111,325	054	111,925	078	112,525	102
110,15		110,75	031	111,35	055	111,95	079	112,55	103
110,175		110,775	032	111,375	056	111,975	080	112,575	104
110,2		110,8	033	111,4	057	112,0	081	112,6	105
110,225		110,825	034	111,425	058	112,025	082	112,625	106
110,25		110,85	035	111,45	059	112,05	083	112,65	
110,275		110,875	036	111,475	060	112,075	084	112,675	
110,3		110,9	037	111,5	061	112,1	085	112,7	
110,325		110,925	038	111,525	062	112,125	086	112,725	
110,35		110,95	039	111,55	063	112,15	087	112,75	
110,375		110,975	040	111,575	064	112,175	088	112,775	
110,4		111,0	041	111,6	065	112,2	089	112,8	
110,425		111,025	042	111,625	066	112,225	090	112,825	
110,45		111,05	043	111,65	067	112,25	091	112,85	
110,475		111,075	044	111,675	068	112,275	092	112,875	
110,5		111,1	045	111,7	069	112,3	093	112,9	
110,525		111,125	046	111,725	070	112,325	094	112,925	
110,55		111,15	047	111,75	071	112,35	095	112,95	
110,575		111,175	048	111,775	072	112,375	096	112,975	

Identificare sulla nuova pompa d'iniezione il numero caratteristico per la lunghezza (A) della pompa d'iniezione, per esempio 53.

Prendere dalla tabella 1 la misura base (L<sub>0</sub>) della pompa di iniezione, per esempio 109 mm.

Determinare lo spessore teorico (T<sub>s</sub>) della rondella:

$$T_s = EK - (L_0 + A/100)$$

$$T_s = 111,725 \text{ mm} - (109 \text{ mm} + 53/100 \text{ mm})$$

$$T_s = 2,195 \text{ mm}$$

Ricavare dalla tabella 2 lo spessore effettivo della rondella (S<sub>s</sub>):

$$T_s 2,195 \text{ mm} = S_s \mathbf{2,2 \text{ mm}}$$

1 1

In tale caso non è necessario disporre né della vecchia pompa d'iniezione né del vecchio spessore.

**Esempio:** su un motore BF6M 1012 è necessario sostituire la pompa d'iniezione del cilindro 3.

Procedimento:

rilevare dalla targhetta motore nei riquadri "EP" il codice EP per il cilindro 3, per esempio 070.  
 (sistema di lettura: riquadro 1 = cilindro 1, riquadro 2 = cilindro 2, e così via)

Prendere nota dalla tabella 3 delle dimensioni d'ingombro corrette (E<sub>K</sub>) della pompa d'iniezione in corrispondenza al codice EP, nel nostro caso 111,725 mm.

**Tabella 3**

E <sub>K</sub> (mm)	Codice EP	E <sub>K</sub> (mm)	Codice EP	E <sub>K</sub> (mm)	Codice EP	E <sub>K</sub> (mm)	Codice EP	E <sub>K</sub> (mm)	Codice EP
110,0		110,6		111,2	049	111,8	073	112,4	097
110,025		110,625		111,225	050	111,825	074	112,425	098
110,05		110,65		111,25	051	111,85	075	112,45	099
110,075		110,675		111,275	052	111,875	076	112,475	100
110,1		110,7		111,3	053	111,9	077	112,5	101
110,125		110,725		111,325	054	111,925	078	112,525	102
110,15		110,75	031	111,35	055	111,95	079	112,55	103
110,175		110,775	032	111,375	056	111,975	080	112,575	104
110,2		110,8	033	111,4	057	112,0	081	112,6	105
110,225		110,825	034	111,425	058	112,025	082	112,625	106
110,25		110,85	035	111,45	059	112,05	083	112,65	
110,275		110,875	036	111,475	060	112,075	084	112,675	
110,3		110,9	037	111,5	061	112,1	085	112,7	
110,325		110,925	038	111,525	062	112,125	086	112,725	
110,35		110,95	039	111,55	063	112,15	087	112,75	
110,375		110,975	040	111,575	064	112,175	088	112,775	
110,4		111,0	041	111,6	065	112,2	089	112,8	
110,425		111,025	042	111,625	066	112,225	090	112,825	
110,45		111,05	043	111,65	067	112,25	091	112,85	
110,475		111,075	044	111,675	068	112,275	092	112,875	
110,5		111,1	045	111,7	069	112,3	093	112,9	
110,525		111,125	046	111,725	070	112,325	094	112,925	
110,55		111,15	047	111,75	071	112,35	095	112,95	
110,575		111,175	048	111,775	072	112,375	096	112,975	

Identificare sulla nuova pompa d'iniezione il numero caratteristico per la lunghezza (A) della pompa d'iniezione, per esempio 53.

Prendere dalla tabella 1 la misura base (L<sub>0</sub>) della pompa di iniezione, per esempio 109 mm.

Determinare lo spessore teorico (T<sub>s</sub>) della rondella:

$$T_s = EK - (L_0 + A/100)$$

$$T_s = 111,725 \text{ mm} - (109 \text{ mm} + 53/100 \text{ mm})$$

$$T_s = 2,195 \text{ mm}$$

Ricavare dalla tabella 2 lo spessore effettivo della rondella (S<sub>s</sub>):

$$T_s 2,195 \text{ mm} = S_s \mathbf{2,2 \text{ mm}}$$



# Ausgleichscheibendicke für Förderbeginn ermitteln bei BFM 1012 Bosch Einspritzpumpentausch im Servicefall. Grundmaß L<sub>0</sub> = 119 mm

Die alte Einspritzpumpe und Ausgleichscheibe ist hierzu nicht erforderlich.

**Beispiel:** An einem BF6M1012 ist die Einspritzpumpe von Zylinder 3 zu ersetzen.

Vorgehensweise:

Vom Firmenschild in der Rubrik "EP" den EP-Code für Zylinder 3 ablesen, z.B. 183.  
(Lesefolge: Zeile 1 = Zyl.1, Zeile 2 = Zyl.2, u.s.w.)

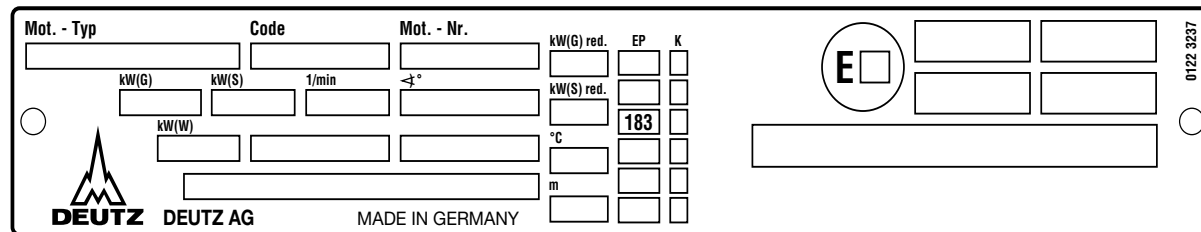

Die alte Einspritzpumpe und Ausgleichscheibe ist hierzu nicht erforderlich.

**Beispiel:** An einem BF6M1012 ist die Einspritzpumpe von Zylinder 3 zu ersetzen.

Vorgehensweise:

Vom Firmenschild in der Rubrik "EP" den EP-Code für Zylinder 3 ablesen, z.B. 183.  
(Lesefolge: Zeile 1 = Zyl.1, Zeile 2 = Zyl.2, u.s.w.)

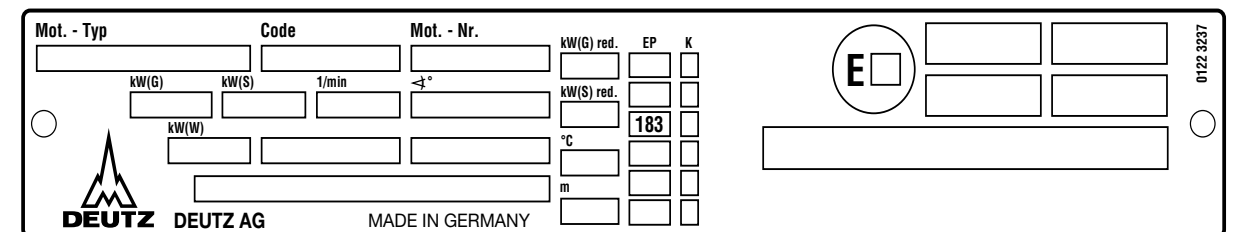

Korrigiertes Einspritzpumpeneinbaumaß (E<sub>K</sub>) aus Tabelle 4 entsprechend dem EP-Code entnehmen, z.B.122,05 mm.

**Tabelle 4**

E <sub>K</sub> (mm)	EP-Code	E <sub>K</sub> (mm)	EP-Code	E <sub>K</sub> (mm)	EP-Code	E <sub>K</sub> (mm)	EP-Code	E <sub>K</sub> (mm)	EP-Code
120,0		120,6		121,2	149	121,8	173	122,4	197
120,025		120,625		121,225	150	121,825	174	122,425	198
120,05		120,65		121,25	151	121,85	175	122,45	199
120,075		120,675		121,275	152	121,875	176	122,475	200
120,1		120,7		121,3	153	121,9	177	122,5	201
120,125		120,725		121,325	154	121,925	178	122,525	202
120,15		120,75	131	121,35	155	121,95	179	122,55	203
120,175		120,775	132	121,375	156	121,975	180	122,575	204
120,2		120,8	133	121,4	157	122,0	181	122,6	205
120,225		120,825	134	121,425	158	122,025	182	122,625	206
120,25		120,85	135	121,45	159	122,05	183	122,65	207
120,275		120,875	136	121,475	160	122,075	184	122,675	208
120,3		120,9	137	121,5	161	122,1	185	122,7	209
120,325		120,925	138	121,525	162	122,125	186	122,725	210
120,35		120,95	139	121,55	163	122,15	187	122,75	211
120,375		120,975	140	121,575	164	122,175	188	122,775	212
120,4		121,0	141	121,6	165	122,2	189	122,8	213
120,425		121,025	142	121,625	166	122,225	190	122,825	214
120,45		121,05	143	121,65	167	122,25	191	122,85	215
120,475		121,075	144	121,675	168	122,275	192	122,875	
120,5		121,1	145	121,7	169	122,3	193	122,9	
120,525		121,125	146	121,725	170	122,325	194	122,925	
120,55		121,15	147	121,75	171	122,35	195	122,95	
120,575		121,175	148	121,775	172	122,375	196	122,975	

Kennzahl für Einspritzpumpenlänge (A) von der neuen Einspritzpumpe ablesen, z.B. 22.

Grundmaß der Einspritzpumpe (L<sub>0</sub>) aus Tabelle 1 entnehmen, z.B. 119 mm.

Theoretische Ausgleichscheibendicke (T<sub>s</sub>) ermitteln.

$$T_s = EK - (L_0 + A/100)$$

$$T_s = 122,05 \text{ mm} - (119 \text{ mm} + 22/100 \text{ mm})$$

$$T_s = 2,83 \text{ mm}$$

Ausgleichscheibendicke (S<sub>s</sub>) nach Tabelle 2 auswählen.

$$T_s 2,83 \text{ mm} = S_s \mathbf{2,8 \text{ mm}}$$

Korrigiertes Einspritzpumpeneinbaumaß (E<sub>K</sub>) aus Tabelle 4 entsprechend dem EP-Code entnehmen, z.B.122,05 mm.

**Tabelle 4**

E <sub>K</sub> (mm)	EP-Code	E <sub>K</sub> (mm)	EP-Code	E <sub>K</sub> (mm)	EP-Code	E <sub>K</sub> (mm)	EP-Code	E <sub>K</sub> (mm)	EP-Code
120,0		120,6		121,2	149	121,8	173	122,4	197
120,025		120,625		121,225	150	121,825	174	122,425	198
120,05		120,65		121,25	151	121,85	175	122,45	199
120,075		120,675		121,275	152	121,875	176	122,475	200
120,1		120,7		121,3	153	121,9	177	122,5	201
120,125		120,725		121,325	154	121,925	178	122,525	202
120,15		120,75	131	121,35	155	121,95	179	122,55	203
120,175		120,775	132	121,375	156	121,975	180	122,575	204
120,2		120,8	133	121,4	157	122,0	181	122,6	205
120,225		120,825	134	121,425	158	122,025	182	122,625	206
120,25		120,85	135	121,45	159	122,05	183	122,65	207
120,275		120,875	136	121,475	160	122,075	184	122,675	208
120,3		120,9	137	121,5	161	122,1	185	122,7	209
120,325		120,925	138	121,525	162	122,125	186	122,725	210
120,35		120,95	139	121,55	163	122,15	187	122,75	211
120,375		120,975	140	121,575	164	122,175	188	122,775	212
120,4		121,0	141	121,6	165	122,2	189	122,8	213
120,425		121,025	142	121,625	166	122,225	190	122,825	214
120,45		121,05	143	121,65	167	122,25	191	122,85	215
120,475		121,075	144	121,675	168	122,275	192	122,875	
120,5		121,1	145	121,7	169	122,3	193	122,9	
120,525		121,125	146	121,725	170	122,325	194	122,925	
120,55		121,15	147	121,75	171	122,35	195	122,95	
120,575		121,175	148	121,775	172	122,375	196	122,975	

Kennzahl für Einspritzpumpenlänge (A) von der neuen Einspritzpumpe ablesen, z.B. 22.

Grundmaß der Einspritzpumpe (L<sub>0</sub>) aus Tabelle 1 entnehmen, z.B. 119 mm.

Theoretische Ausgleichscheibendicke (T<sub>s</sub>) ermitteln.

$$T_s = EK - (L_0 + A/100)$$

$$T_s = 122,05 \text{ mm} - (119 \text{ mm} + 22/100 \text{ mm})$$

$$T_s = 2,83 \text{ mm}$$

Ausgleichscheibendicke (S<sub>s</sub>) nach Tabelle 2 auswählen.

$$T_s 2,83 \text{ mm} = S_s \mathbf{2,8 \text{ mm}}$$





# Determining shim thickness for Bosch injection pump replacement on BFM 1012 in case of service. Standard dimensions L<sub>0</sub> = 119 mm

The old injection pump with shim is not required for such purpose.

**Example:** The injection pump of cylinder 3 is to be replaced on a BFM 1012 engine.

Procedure:

Read off EP code for cylinder 3 from nameplate under column „EP“, e.g. 183.  
(Reading sequence: line 1=cyl.1, line 2 = cyl.2, etc.)

Take corrected injection pump installation dimension (E<sub>K</sub>) from table 4 according to EP code, e.g. 122.05 mm.

**Tabelle 4**

E <sub>K</sub> (mm)	EP code	E <sub>K</sub> (mm)	EP code	E <sub>K</sub> (mm)	EP code	E <sub>K</sub> (mm)	EP code	E <sub>K</sub> (mm)	EP code
120.0		120.6		121.2	149	121.8	173	122.4	197
120.025		120.625		121.225	150	121.825	174	122.425	198
120.05		120.65		121.25	151	121.85	175	122.45	199
120.075		120.675		121.275	152	121.875	176	122.475	200
120.1		120.7		121.3	153	121.9	177	122.5	201
120.125		120.725		121.325	154	121.925	178	122.525	202
120.15		120.75	131	121.35	155	121.95	179	122.55	203
120.175		120.775	132	121.375	156	121.975	180	122.575	204
120.2		120.8	133	121.4	157	122.0	181	122.6	205
120.225		120.825	134	121.425	158	122.025	182	122.625	206
120.25		120.85	135	121.45	159	122.05	183	122.65	207
120.275		120.875	136	121.475	160	122.075	184	122.675	208
120.3		120.9	137	121.5	161	122.1	185	122.7	209
120.325		120.925	138	121.525	162	122.125	186	122.725	210
120.35		120.95	139	121.55	163	122.15	187	122.75	211
120.375		120.975	140	121.575	164	122.175	188	122.775	212
120.4		121.0	141	121.6	165	122.2	189	122.8	213
120.425		121.025	142	121.625	166	122.225	190	122.825	214
120.45		121.05	143	121.65	167	122.25	191	122.85	215
120.475		121.075	144	121.675	168	122.275	192	122.875	
120.5		121.1	145	121.7	169	122.3	193	122.9	
120.525		121.125	146	121.725	170	122.325	194	122.925	
120.55		121.15	147	121.75	171	122.35	195	122.95	
120.575		121.175	148	121.775	172	122.375	196	112.975	

Take code for injection pump length (A) from new injection pump, e.g. 22.

Take standard dimension of injection pump (L<sub>0</sub>) from table 1, e.g. 119 mm.

Determine theoretical shim thickness (T<sub>s</sub>).

$$T_s = E_K - (L_0 + A/100)$$

$$T_s = 122.05 \text{ mm} - (119 \text{ mm} + 22/100 \text{ mm})$$

$$T_s = 2.83 \text{ mm}$$

Select shim thickness (S<sub>s</sub>) according to table 2.

$$T_s 2.83 \text{ mm} = S_s \mathbf{2.8 \text{ mm}}$$

1 1

The old injection pump with shim is not required for such purpose.

**Example:** The injection pump of cylinder 3 is to be replaced on a BFM 1012 engine.

Procedure:

Read off EP code for cylinder 3 from nameplate under column „EP“, e.g. 183.  
(Reading sequence: line 1=cyl.1, line 2 = cyl.2, etc.)

Take corrected injection pump installation dimension (E<sub>K</sub>) from table 4 according to EP code, e.g. 122.05 mm.

**Tabelle 4**

E <sub>K</sub> (mm)	EP code	E <sub>K</sub> (mm)	EP code	E <sub>K</sub> (mm)	EP code	E <sub>K</sub> (mm)	EP code	E <sub>K</sub> (mm)	EP code
120.0		120.6		121.2	149	121.8	173	122.4	197
120.025		120.625		121.225	150	121.825	174	122.425	198
120.05		120.65		121.25	151	121.85	175	122.45	199
120.075		120.675		121.275	152	121.875	176	122.475	200
120.1		120.7		121.3	153	121.9	177	122.5	201
120.125		120.725		121.325	154	121.925	178	122.525	202
120.15		120.75	131	121.35	155	121.95	179	122.55	203
120.175		120.775	132	121.375	156	121.975	180	122.575	204
120.2		120.8	133	121.4	157	122.0	181	122.6	205
120.225		120.825	134	121.425	158	122.025	182	122.625	206
120.25		120.85	135	121.45	159	122.05	183	122.65	207
120.275		120.875	136	121.475	160	122.075	184	122.675	208
120.3		120.9	137	121.5	161	122.1	185	122.7	209
120.325		120.925	138	121.525	162	122.125	186	122.725	210
120.35		120.95	139	121.55	163	122.15	187	122.75	211
120.375		120.975	140	121.575	164	122.175	188	122.775	212
120.4		121.0	141	121.6	165	122.2	189	122.8	213
120.425		121.025	142	121.625	166	122.225	190	122.825	214
120.45		121.05	143	121.65	167	122.25	191	122.85	215
120.475		121.075	144	121.675	168	122.275	192	122.875	
120.5		121.1	145	121.7	169	122.3	193	122.9	
120.525		121.125	146	121.725	170	122.325	194	122.925	
120.55		121.15	147	121.75	171	122.35	195	122.95	
120.575		121.175	148	121.775	172	122.375	196	112.975	

Take code for injection pump length (A) from new injection pump, e.g. 22.

Take standard dimension of injection pump (L<sub>0</sub>) from table 1, e.g. 119 mm.

Determine theoretical shim thickness (T<sub>s</sub>).

$$T_s = E_K - (L_0 + A/100)$$

$$T_s = 122.05 \text{ mm} - (119 \text{ mm} + 22/100 \text{ mm})$$

$$T_s = 2.83 \text{ mm}$$

Select shim thickness (S<sub>s</sub>) according to table 2.

$$T_s 2.83 \text{ mm} = S_s \mathbf{2.8 \text{ mm}}$$



# Calcul de l'épaisseur des rondelles d'épaisseur pour le début d'injection pour remplacement de pompe d'injection Bosch BFM 1012 en intervention SAV. Cote de base L<sub>0</sub> = 119 mm

L'ancienne pompe d'injection et la rondelle d'épaisseur ne sont pas nécessaires pour cela.

**Exemple :** remplacement de la pompe d'injection du cylindre 3 sur le BF6M 1012.

Procédure à suivre :

Lire sur la plaque d'identification du constructeur à la rubrique „EP“ le code EP pour le cylindre 3, exemple : 183, ensuite comme suit : ligne 1 = cyl. 1, ligne 2 = cyl. 2 etc.

Cote de montage corrigé de la pompe d'injection (E<sub>k</sub>) relevée dans le tableau 4 correspondant au code EP.  
Exemple 122,05 mm

**Tableau 4**

E <sub>k</sub> (mm)	Code EP	E <sub>k</sub> (mm)	Code EP	E <sub>k</sub> (mm)	Code EP	E <sub>k</sub> (mm)	Code EP	E <sub>k</sub> (mm)	Code EP
120,0		120,6		121,2	149	121,8	173	122,4	197
120,025		120,625		121,225	150	121,825	174	122,425	198
120,05		120,65		121,25	151	121,85	175	122,45	199
120,075		120,675		121,275	152	121,875	176	122,475	200
120,1		120,7		121,3	153	121,9	177	122,5	201
120,125		120,725		121,325	154	121,925	178	122,525	202
120,15		120,75	131	121,35	155	121,95	179	122,55	203
120,175		120,775	132	121,375	156	121,975	180	122,575	204
120,2		120,8	133	121,4	157	122,0	181	122,6	205
120,225		120,825	134	121,425	158	122,025	182	122,625	206
120,25		120,85	135	121,45	159	122,05	183	122,65	207
120,275		120,875	136	121,475	160	122,075	184	122,675	208
120,3		120,9	137	121,5	161	122,1	185	122,7	209
120,325		120,925	138	121,525	162	122,125	186	122,725	210
120,35		120,95	139	121,55	163	122,15	187	122,75	211
120,375		120,975	140	121,575	164	122,175	188	122,775	212
120,4		121,0	141	121,6	165	122,2	189	122,8	213
120,425		121,025	142	121,625	166	122,225	190	122,825	214
120,45		121,05	143	121,65	167	122,25	191	122,85	215
120,475		121,075	144	121,675	168	122,275	192	122,875	
120,5		121,1	145	121,7	169	122,3	193	122,9	
120,525		121,125	146	121,725	170	122,325	194	122,925	
120,55		121,15	147	121,75	171	122,35	195	122,95	
120,575		121,175	148	121,775	172	122,375	196	122,975	

Consulter le tableau indiquant l'indice de longueur de la pompe d'injection (A) (nouvelle pompe d'injection), exemple 22.

La cote de base de la pompe d'injection (L<sub>0</sub>) est indiquée dans le tableau 1, exemple 119 mm.

Calculer l'épaisseur théorique (T<sub>s</sub>) des rondelles d'épaisseur

$$T_s = E_k - (L_0 + A/100)$$

$$T_s = 122,05 \text{ mm} - (119 \text{ mm} + 22/100 \text{ mm})$$

$$T_s = 2,83 \text{ mm}$$

Choisir l'épaisseur des rondelles d'épaisseur (S<sub>s</sub>) selon le tableau 2

$$T_s 2,83 \text{ mm} = S_s \mathbf{2,8 \text{ mm}}$$

1 1

L'ancienne pompe d'injection et la rondelle d'épaisseur ne sont pas nécessaires pour cela.

**Exemple :** remplacement de la pompe d'injection du cylindre 3 sur le BF6M 1012.

Procédure à suivre :

Lire sur la plaque d'identification du constructeur à la rubrique „EP“ le code EP pour le cylindre 3, exemple : 183, ensuite comme suit : ligne 1 = cyl. 1, ligne 2 = cyl. 2 etc.

Cote de montage corrigé de la pompe d'injection (E<sub>k</sub>) relevée dans le tableau 4 correspondant au code EP.  
Exemple 122,05 mm

**Tableau 4**

E <sub>k</sub> (mm)	Code EP	E <sub>k</sub> (mm)	Code EP	E <sub>k</sub> (mm)	Code EP	E <sub>k</sub> (mm)	Code EP	E <sub>k</sub> (mm)	Code EP
120,0		120,6		121,2	149	121,8	173	122,4	197
120,025		120,625		121,225	150	121,825	174	122,425	198
120,05		120,65		121,25	151	121,85	175	122,45	199
120,075		120,675		121,275	152	121,875	176	122,475	200
120,1		120,7		121,3	153	121,9	177	122,5	201
120,125		120,725		121,325	154	121,925	178	122,525	202
120,15		120,75	131	121,35	155	121,95	179	122,55	203
120,175		120,775	132	121,375	156	121,975	180	122,575	204
120,2		120,8	133	121,4	157	122,0	181	122,6	205
120,225		120,825	134	121,425	158	122,025	182	122,625	206
120,25		120,85	135	121,45	159	122,05	183	122,65	207
120,275		120,875	136	121,475	160	122,075	184	122,675	208
120,3		120,9	137	121,5	161	122,1	185	122,7	209
120,325		120,925	138	121,525	162	122,125	186	122,725	210
120,35		120,95	139	121,55	163	122,15	187	122,75	211
120,375		120,975	140	121,575	164	122,175	188	122,775	212
120,4		121,0	141	121,6	165	122,2	189	122,8	213
120,425		121,025	142	121,625	166	122,225	190	122,825	214
120,45		121,05	143	121,65	167	122,25	191	122,85	215
120,475		121,075	144	121,675	168	122,275	192	122,875	
120,5		121,1	145	121,7	169	122,3	193	122,9	
120,525		121,125	146	121,725	170	122,325	194	122,925	
120,55		121,15	147	121,75	171	122,35	195	122,95	
120,575		121,175	148	121,775	172	122,375	196	122,975	

Consulter le tableau indiquant l'indice de longueur de la pompe d'injection (A) (nouvelle pompe d'injection), exemple 22.

La cote de base de la pompe d'injection (L<sub>0</sub>) est indiquée dans le tableau 1, exemple 119 mm.

Calculer l'épaisseur théorique (T<sub>s</sub>) des rondelles d'épaisseur

$$T_s = E_k - (L_0 + A/100)$$

$$T_s = 122,05 \text{ mm} - (119 \text{ mm} + 22/100 \text{ mm})$$

$$T_s = 2,83 \text{ mm}$$

Choisir l'épaisseur des rondelles d'épaisseur (S<sub>s</sub>) selon le tableau 2

$$T_s 2,83 \text{ mm} = S_s \mathbf{2,8 \text{ mm}}$$



# Determinazione dello spessore delle rondelle per l'inizio di mandata nel BFM 1012

## Sostituzione della pompa d'iniezione Bosch a cura del service.

### Misura base L<sub>0</sub>= 119 mm

In tale caso non è necessario disporre né della vecchia pompa d'iniezione né del vecchio spessore.

**Esempio:** su un motore BF6M 1012 è necessario sostituire la pompa d'iniezione del cilindro 3.

Procedimento:

rilevare dalla targhetta motore nei riquadri "EP" il codice EP per il cilindro 3, per esempio 183.  
(sistema di lettura: riquadro 1 = cilindro 1, riquadro 2 = cilindro 2, e così via)

Prendere nota dalla tabella 4 delle dimensioni d'ingombro (E<sub>K</sub>) della pompa d'iniezione in corrispondenza al codice EP, nel nostro caso 122,05 mm.

**Tabelle 4**

E <sub>K</sub> (mm)	Codice EP	E <sub>K</sub> (mm)	Codice EP	E <sub>K</sub> (mm)	Codice EP	E <sub>K</sub> (mm)	Codice EP	E <sub>K</sub> (mm)	Codice EP
120,0		120,6		121,2	149	121,8	173	122,4	197
120,025		120,625		121,225	150	121,825	174	122,425	198
120,05		120,65		121,25	151	121,85	175	122,45	199
120,075		120,675		121,275	152	121,875	176	122,475	200
120,1		120,7		121,3	153	121,9	177	122,5	201
120,125		120,725		121,325	154	121,925	178	122,525	202
120,15		120,75	131	121,35	155	121,95	179	122,55	203
120,175		120,775	132	121,375	156	121,975	180	122,575	204
120,2		120,8	133	121,4	157	122,0	181	122,6	205
120,225		120,825	134	121,425	158	122,025	182	122,625	206
120,25		120,85	135	121,45	159	122,05	183	122,65	207
120,275		120,875	136	121,475	160	122,075	184	122,675	208
120,3		120,9	137	121,5	161	122,1	185	122,7	209
120,325		120,925	138	121,525	162	122,125	186	122,725	210
120,35		120,95	139	121,55	163	122,15	187	122,75	211
120,375		120,975	140	121,575	164	122,175	188	122,775	212
120,4		121,0	141	121,6	165	122,2	189	122,8	213
120,425		121,025	142	121,625	166	122,225	190	122,825	214
120,45		121,05	143	121,65	167	122,25	191	122,85	215
120,475		121,075	144	121,675	168	122,275	192	122,875	
120,5		121,1	145	121,7	169	122,3	193	122,9	
120,525		121,125	146	121,725	170	122,325	194	122,925	
120,55		121,15	147	121,75	171	122,35	195	122,95	
120,575		121,175	148	121,775	172	122,375	196	122,975	

Identificare sulla nuova pompa d'iniezione il numero caratteristico per la lunghezza (A) della pompa d'iniezione, per esempio 22.

Prendere dalla tabella 1 la misura base (L<sub>0</sub>) della pompa di iniezione, per esempio 119 mm.

Determinare lo spessore teorico (T<sub>s</sub>) della rondella:

$$T_s = EK - (L_0 + A/100)$$

$$T_s = 122,05 \text{ mm} - (119 \text{ mm} + 22/100 \text{ mm})$$

$$T_s = 2,83 \text{ mm}$$

Ricavare dalla tabella 2 lo spessore effettivo della rondella (S<sub>s</sub>):

$$T_s 2,83 \text{ mm} = S_s \mathbf{2,8 \text{ mm}}$$

1 1

In tale caso non è necessario disporre né della vecchia pompa d'iniezione né del vecchio spessore.

**Esempio:** su un motore BF6M 1012 è necessario sostituire la pompa d'iniezione del cilindro 3.

Procedimento:

rilevare dalla targhetta motore nei riquadri "EP" il codice EP per il cilindro 3, per esempio 183.  
(sistema di lettura: riquadro 1 = cilindro 1, riquadro 2 = cilindro 2, e così via)

Prendere nota dalla tabella 4 delle dimensioni d'ingombro (E<sub>K</sub>) della pompa d'iniezione in corrispondenza al codice EP, nel nostro caso 122,05 mm.

**Tabelle 4**

E <sub>K</sub> (mm)	Codice EP	E <sub>K</sub> (mm)	Codice EP	E <sub>K</sub> (mm)	Codice EP	E <sub>K</sub> (mm)	Codice EP	E <sub>K</sub> (mm)	Codice EP
120,0		120,6		121,2	149	121,8	173	122,4	197
120,025		120,625		121,225	150	121,825	174	122,425	198
120,05		120,65		121,25	151	121,85	175	122,45	199
120,075		120,675		121,275	152	121,875	176	122,475	200
120,1		120,7		121,3	153	121,9	177	122,5	201
120,125		120,725		121,325	154	121,925	178	122,525	202
120,15		120,75	131	121,35	155	121,95	179	122,55	203
120,175		120,775	132	121,375	156	121,975	180	122,575	204
120,2		120,8	133	121,4	157	122,0	181	122,6	205
120,225		120,825	134	121,425	158	122,025	182	122,625	206
120,25		120,85	135	121,45	159	122,05	183	122,65	207
120,275		120,875	136	121,475	160	122,075	184	122,675	208
120,3		120,9	137	121,5	161	122,1	185	122,7	209
120,325		120,925	138	121,525	162	122,125	186	122,725	210
120,35		120,95	139	121,55	163	122,15	187	122,75	211
120,375		120,975	140	121,575	164	122,175	188	122,775	212
120,4		121,0	141	121,6	165	122,2	189	122,8	213
120,425		121,025	142	121,625	166	122,225	190	122,825	214
120,45		121,05	143	121,65	167	122,25	191	122,85	215
120,475		121,075	144	121,675	168	122,275	192	122,875	
120,5		121,1	145	121,7	169	122,3	193	122,9	
120,525		121,125	146	121,725	170	122,325	194	122,925	
120,55		121,15	147	121,75	171	122,35	195	122,95	
120,575		121,175	148	121,775	172	122,375	196	122,975	

Identificare sulla nuova pompa d'iniezione il numero caratteristico per la lunghezza (A) della pompa d'iniezione, per esempio 22.

Prendere dalla tabella 1 la misura base (L<sub>0</sub>) della pompa di iniezione, per esempio 119 mm.

Determinare lo spessore teorico (T<sub>s</sub>) della rondella:

$$T_s = EK - (L_0 + A/100)$$

$$T_s = 122,05 \text{ mm} - (119 \text{ mm} + 22/100 \text{ mm})$$

$$T_s = 2,83 \text{ mm}$$

Ricavare dalla tabella 2 lo spessore effettivo della rondella (S<sub>s</sub>):

$$T_s 2,83 \text{ mm} = S_s \mathbf{2,8 \text{ mm}}$$



# Ausgleichscheibendicke für Förderbeginn ermitteln bei BFM 1013 Bosch Einspritzpumpentausch im Servicefall. Grundmaß L<sub>0</sub> = 143 mm

Die alte Einspritzpumpe und Ausgleichscheibe ist hierzu nicht erforderlich.

**Beispiel:** An einem BF6M1013 ist die Einspritzpumpe von Zylinder 3 zu ersetzen.

Vorgehensweise:

Vom Firmenschild in der Rubrik "EP" den EP-Code für Zylinder 3 ablesen, z.B. 397.  
(Lesefolge: Zeile 1 = Zyl.1, Zeile 2 = Zyl.2, u.s.w.)

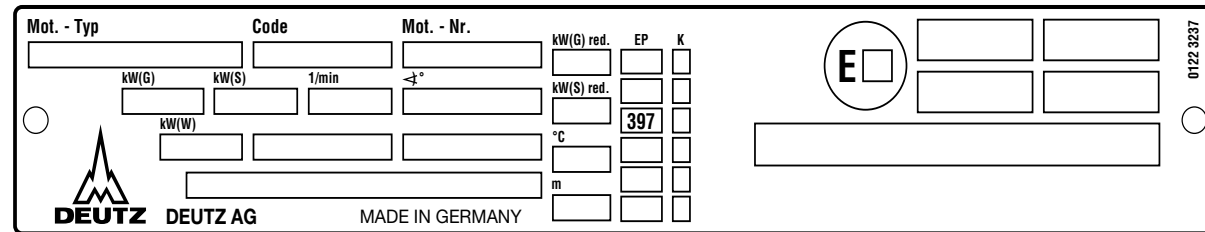

Korrigiertes Einspritzpumpeneinbaumaß (E<sub>K</sub>) aus Tabelle 5 entsprechend dem EP-Code entnehmen, z.B.146,9 mm.

Tabelle 5

E <sub>K</sub> (mm)	EP-Code	E <sub>K</sub> (mm)	EP-Code	E <sub>K</sub> (mm)	EP-Code	E <sub>K</sub> (mm)	EP-Code	E <sub>K</sub> (mm)	EP-Code
144,5		145,1		145,7	349	146,3	373	146,9	397
144,525		145,125		145,725	350	146,325	374	146,925	398
144,55		145,15		145,75	351	146,35	375	146,95	399
144,575		145,175		145,775	352	146,375	376	146,975	400
144,6		145,2		145,8	353	146,4	377	147,0	401
144,625		145,225		145,825	354	146,425	378	147,025	
144,65		145,25		145,85	355	146,45	379	147,05	
144,675		145,275		145,875	356	146,475	380	147,075	
144,7		145,3		145,9	357	146,5	381	147,1	
144,725		145,325		145,925	358	146,525	382	147,125	
144,75		145,35	335	145,95	359	146,55	383	147,15	
144,775		145,375	336	145,975	360	146,575	384	147,175	
144,8		145,4	337	146,0	361	146,6	385	147,2	
144,825		145,425	338	146,025	362	146,625	386	147,225	
144,85		145,45	339	146,05	363	146,65	387	147,25	
144,875		145,475	340	146,075	364	146,675	388	147,275	
144,9		145,5	341	146,1	365	146,7	389	147,3	
144,925		145,525	342	146,125	366	146,725	390	147,325	
144,95		145,55	343	146,15	367	146,75	391	147,35	
144,975		145,575	344	146,175	368	146,775	392	147,375	
145,0		145,6	345	146,2	369	146,8	393	147,4	
145,025		145,625	346	146,225	370	146,825	394	147,425	
145,05		145,65	347	146,25	371	146,85	395	147,45	
145,075		145,675	348	146,275	372	146,875	396	147,475	

Kennzahl für Einspritzpumpenlänge (A) von der neuen Einspritzpumpe ablesen, z.B. 133.

Grundmaß der Einspritzpumpe (L<sub>0</sub>) aus Tabelle 1 entnehmen, z.B. 143 mm.

Theoretische Ausgleichscheibendicke (T<sub>s</sub>) ermitteln.

$$T_s = EK - (L_0 + A/100)$$

$$T_s = 146,9 \text{ mm} - (143 \text{ mm} + 133/100 \text{ mm})$$

$$T_s = 2,57 \text{ mm}$$

Ausgleichscheibendicke (S<sub>s</sub>) nach Tabelle 2 auswählen.

$$T_s 2,57 \text{ mm} = S_s \mathbf{2,6mm}$$

1 1

Die alte Einspritzpumpe und Ausgleichscheibe ist hierzu nicht erforderlich.

**Beispiel:** An einem BF6M1013 ist die Einspritzpumpe von Zylinder 3 zu ersetzen.

Vorgehensweise:

Vom Firmenschild in der Rubrik "EP" den EP-Code für Zylinder 3 ablesen, z.B. 397.  
(Lesefolge: Zeile 1 = Zyl.1, Zeile 2 = Zyl.2, u.s.w.)

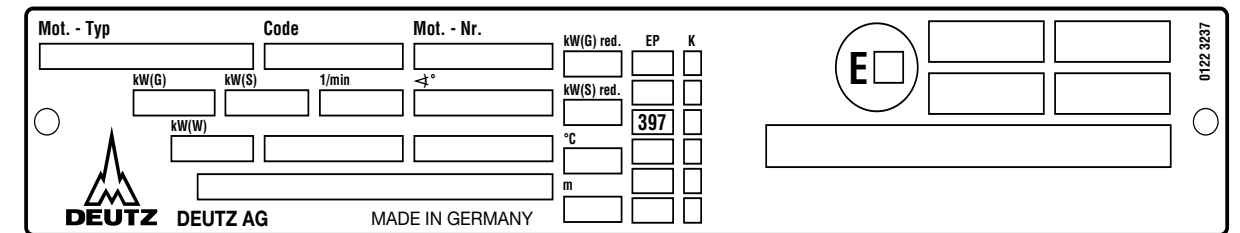

Korrigiertes Einspritzpumpeneinbaumaß (E<sub>K</sub>) aus Tabelle 5 entsprechend dem EP-Code entnehmen, z.B.146,9 mm.

Tabelle 5

E <sub>K</sub> (mm)	EP-Code	E <sub>K</sub> (mm)	EP-Code	E <sub>K</sub> (mm)	EP-Code	E <sub>K</sub> (mm)	EP-Code	E <sub>K</sub> (mm)	EP-Code
144,5		145,1		145,7	349	146,3	373	146,9	397
144,525		145,125		145,725	350	146,325	374	146,925	398
144,55		145,15		145,75	351	146,35	375	146,95	399
144,575		145,175		145,775	352	146,375	376	146,975	400
144,6		145,2		145,8	353	146,4	377	147,0	401
144,625		145,225		145,825	354	146,425	378	147,025	
144,65		145,25		145,85	355	146,45	379	147,05	
144,675		145,275		145,875	356	146,475	380	147,075	
144,7		145,3		145,9	357	146,5	381	147,1	
144,725		145,325		145,925	358	146,525	382	147,125	
144,75		145,35	335	145,95	359	146,55	383	147,15	
144,775		145,375	336	145,975	360	146,575	384	147,175	
144,8		145,4	337	146,0	361	146,6	385	147,2	
144,825		145,425	338	146,025	362	146,625	386	147,225	
144,85		145,45	339	146,05	363	146,65	387	147,25	
144,875		145,475	340	146,075	364	146,675	388	147,275	
144,9		145,5	341	146,1	365	146,7	389	147,3	
144,925		145,525	342	146,125	366	146,725	390	147,325	
144,95		145,55	343	146,15	367	146,75	391	147,35	
144,975		145,575	344	146,175	368	146,775	392	147,375	
145,0		145,6	345	146,2	369	146,8	393	147,4	
145,025		145,625	346	146,225	370	146,825	394	147,425	
145,05		145,65	347	146,25	371	146,85	395	147,45	
145,075		145,675	348	146,275	372	146,875	396	147,475	

Kennzahl für Einspritzpumpenlänge (A) von der neuen Einspritzpumpe ablesen, z.B. 133.

Grundmaß der Einspritzpumpe (L<sub>0</sub>) aus Tabelle 1 entnehmen, z.B. 143 mm.

Theoretische Ausgleichscheibendicke (T<sub>s</sub>) ermitteln.

$$T_s = EK - (L_0 + A/100)$$

$$T_s = 146,9 \text{ mm} - (143 \text{ mm} + 133/100 \text{ mm})$$

$$T_s = 2,57 \text{ mm}$$

Ausgleichscheibendicke (S<sub>s</sub>) nach Tabelle 2 auswählen.

$$T_s 2,57 \text{ mm} = S_s \mathbf{2,6mm}$$





# Determining shim thickness for Bosch injection pump replacement on BFM 1013 in case of service. Standard dimensions L<sub>0</sub> = 143 mm

The old injection pump with shim is not required for such purpose.

**Example:** The injection pump of cylinder 3 is to be replaced on a BFM 1013 engine.

Procedure:

Read off EP code for cylinder 3 from nameplate under column „EP“, e.g. 397.  
(Reading sequence: line 1=cyl.1, line 2 = cyl.2, etc.)

The nameplate shows fields for Mot.-Typ, Code, Mot.-Nr., kW(G) red., EP, K, kW(S) red., kW(W), °C, and m. A circled 'E' code is highlighted, with the value 397 visible in the EP field.

Take corrected injection pump installation dimension (E<sub>K</sub>) from table 5 according to EP code, e.g. 146.9 mm.

**Table 5**

E <sub>K</sub> (mm)	EP code	E <sub>K</sub> (mm)	EP code	E <sub>K</sub> (mm)	EP code	E <sub>K</sub> (mm)	EP code	E <sub>K</sub> (mm)	EP code
144.5		145.1		145.7	349	146.3	373	146.9	397
144.525		145.125		145.725	350	146.325	374	146.925	398
144.55		145.15		145.75	351	146.35	375	146.95	399
144.575		145.175		145.775	352	146.375	376	146.975	400
144.6		145.2		145.8	353	146.4	377	147.0	401
144.625		145.225		145.825	354	146.425	378	147.025	
144.65		145.25		145.85	355	146.45	379	147.05	
144.675		145.275		145.875	356	146.475	380	147.075	
144.7		145.3		145.9	357	146.5	381	147.1	
144.725		145.325		145.925	358	146.525	382	147.125	
144.75		145.35	335	145.95	359	146.55	383	147.15	
144.775		145.375	336	145.975	360	146.575	384	147.175	
144.8		145.4	337	146.0	361	146.6	385	147.2	
144.825		145.425	338	146.025	362	146.625	386	147.225	
144.85		145.45	339	146.05	363	146.65	387	147.25	
144.875		145.475	340	146.075	364	146.675	388	147.275	
144.9		145.5	341	146.1	365	146.7	389	147.3	
144.925		145.525	342	146.125	366	146.725	390	147.325	
144.95		145.55	343	146.15	367	146.75	391	147.35	
144.975		145.575	344	146.175	368	146.775	392	147.375	
145.0		145.6	345	146.2	369	146.8	393	147.4	
145.025		145.625	346	146.225	370	146.825	394	147.425	
145.05		145.65	347	146.25	371	146.85	395	147.45	
145.075		145.675	348	146.275	372	146.875	396	147.475	

Take code for injection pump length (A) from new injection pump, e.g. 133.

Take standard dimension of injection pump (L<sub>0</sub>) from table 1, e.g. 143 mm.

Determine theoretical shim thickness (T<sub>s</sub>).

$$T_s = E_K - (L_0 + A/100)$$

$$T_s = 146.9 \text{ mm} - (143 \text{ mm} + 133/100 \text{ mm})$$

$$T_s = 2.57 \text{ mm}$$

Select shim thickness (S<sub>s</sub>) according to table 2.

$$T_s 2.57 \text{ mm} = S_s \mathbf{2.6 \text{ mm}}$$

1 1

The old injection pump with shim is not required for such purpose.

**Example:** The injection pump of cylinder 3 is to be replaced on a BFM 1013 engine.

Procedure:

Read off EP code for cylinder 3 from nameplate under column „EP“, e.g. 397.  
(Reading sequence: line 1=cyl.1, line 2 = cyl.2, etc.)

The nameplate shows fields for Mot.-Typ, Code, Mot.-Nr., kW(G) red., EP, K, kW(S) red., kW(W), °C, and m. A circled 'E' code is highlighted, with the value 397 visible in the EP field.

Take corrected injection pump installation dimension (E<sub>K</sub>) from table 5 according to EP code, e.g. 146.9 mm.

**Table 5**

E <sub>K</sub> (mm)	EP code	E <sub>K</sub> (mm)	EP code	E <sub>K</sub> (mm)	EP code	E <sub>K</sub> (mm)	EP code	E <sub>K</sub> (mm)	EP code
144.5		145.1		145.7	349	146.3	373	146.9	397
144.525		145.125		145.725	350	146.325	374	146.925	398
144.55		145.15		145.75	351	146.35	375	146.95	399
144.575		145.175		145.775	352	146.375	376	146.975	400
144.6		145.2		145.8	353	146.4	377	147.0	401
144.625		145.225		145.825	354	146.425	378	147.025	
144.65		145.25		145.85	355	146.45	379	147.05	
144.675		145.275		145.875	356	146.475	380	147.075	
144.7		145.3		145.9	357	146.5	381	147.1	
144.725		145.325		145.925	358	146.525	382	147.125	
144.75		145.35	335	145.95	359	146.55	383	147.15	
144.775		145.375	336	145.975	360	146.575	384	147.175	
144.8		145.4	337	146.0	361	146.6	385	147.2	
144.825		145.425	338	146.025	362	146.625	386	147.225	
144.85		145.45	339	146.05	363	146.65	387	147.25	
144.875		145.475	340	146.075	364	146.675	388	147.275	
144.9		145.5	341	146.1	365	146.7	389	147.3	
144.925		145.525	342	146.125	366	146.725	390	147.325	
144.95		145.55	343	146.15	367	146.75	391	147.35	
144.975		145.575	344	146.175	368	146.775	392	147.375	
145.0		145.6	345	146.2	369	146.8	393	147.4	
145.025		145.625	346	146.225	370	146.825	394	147.425	
145.05		145.65	347	146.25	371	146.85	395	147.45	
145.075		145.675	348	146.275	372	146.875	396	147.475	

Take code for injection pump length (A) from new injection pump, e.g. 133.

Take standard dimension of injection pump (L<sub>0</sub>) from table 1, e.g. 143 mm.

Determine theoretical shim thickness (T<sub>s</sub>).

$$T_s = E_K - (L_0 + A/100)$$

$$T_s = 146.9 \text{ mm} - (143 \text{ mm} + 133/100 \text{ mm})$$

$$T_s = 2.57 \text{ mm}$$

Select shim thickness (S<sub>s</sub>) according to table 2.

$$T_s 2.57 \text{ mm} = S_s \mathbf{2.6 \text{ mm}}$$



# Calcul de l'épaisseur des rondelles d'épaisseur pour le début d'injection pour remplacement de pompe d'injection Bosch BFM 1013 en intervention SAV. Cote de base L<sub>0</sub> = 143 mm

L'ancienne pompe d'injection et la rondelle d'épaisseur ne sont pas nécessaires pour cela.

**Exemple :** remplacement de la pompe d'injection du cylindre 3 sur le BF6M 1013.

Procédure à suivre :

Lire sur la plaque d'identification du constructeur à la rubrique „EP“ le code EP pour le cylindre 3, exemple : 397, ensuite comme suit : ligne 1 = cyl. 1, ligne 2 = cyl. 2 etc.

Cote de montage corrigé de la pompe d'injection (E<sub>k</sub>) relevée dans le tableau 5 correspondant au code EP.  
Exemple 146,9 mm

**Tableau 5**

E <sub>K</sub> (mm)	Code EP	E <sub>K</sub> (mm)	Code EP	E <sub>K</sub> (mm)	Code EP	E <sub>K</sub> (mm)	Code EP	E <sub>K</sub> (mm)	Code EP
144,5		145,1		145,7	349	146,3	373	146,9	397
144,525		145,125		145,725	350	146,325	374	146,925	398
144,55		145,15		145,75	351	146,35	375	146,95	399
144,575		145,175		145,775	352	146,375	376	146,975	400
144,6		145,2		145,8	353	146,4	377	147,0	401
144,625		145,225		145,825	354	146,425	378	147,025	
144,65		145,25		145,85	355	146,45	379	147,05	
144,675		145,275		145,875	356	146,475	380	147,075	
144,7		145,3		145,9	357	146,5	381	147,1	
144,725		145,325		145,925	358	146,525	382	147,125	
144,75		145,35	335	145,95	359	146,55	383	147,15	
144,775		145,375	336	145,975	360	146,575	384	147,175	
144,8		145,4	337	146,0	361	146,6	385	147,2	
144,825		145,425	338	146,025	362	146,625	386	147,225	
144,85		145,45	339	146,05	363	146,65	387	147,25	
144,875		145,475	340	146,075	364	146,675	388	147,275	
144,9		145,5	341	146,1	365	146,7	389	147,3	
144,925		145,525	342	146,125	366	146,725	390	147,325	
144,95		145,55	343	146,15	367	146,75	391	147,35	
144,975		145,575	344	146,175	368	146,775	392	147,375	
145,0		145,6	345	146,2	369	146,8	393	147,4	
145,025		145,625	346	146,225	370	146,825	394	147,425	
145,05		145,65	347	146,25	371	146,85	395	147,45	
145,075		145,675	348	146,275	372	146,875	396	147,475	

Consulter le tableau indiquant l'indice de longueur de la pompe d'injection (A) (nouvelle pompe d'injection), exemple 133.

La cote de base de la pompe d'injection (L<sub>0</sub>) est indiquée dans le tableau 1, exemple 143 mm.

Calculer l'épaisseur théorique (T<sub>s</sub>) des rondelles d'épaisseur

$$T_s = E_K - (L_0 + A/100)$$

$$T_s = 146,9 \text{ mm} - (143 \text{ mm} + 133/100 \text{ mm})$$

$$T_s = 2,57 \text{ mm}$$

Choisir l'épaisseur des rondelles d'épaisseur (S<sub>s</sub>) selon le tableau 2

$$T_s 2,57 \text{ mm} = S_s \mathbf{2,6 \text{ mm}}$$

1 1

L'ancienne pompe d'injection et la rondelle d'épaisseur ne sont pas nécessaires pour cela.

**Exemple :** remplacement de la pompe d'injection du cylindre 3 sur le BF6M 1013.

Procédure à suivre :

Lire sur la plaque d'identification du constructeur à la rubrique „EP“ le code EP pour le cylindre 3, exemple : 397, ensuite comme suit : ligne 1 = cyl. 1, ligne 2 = cyl. 2 etc.

Cote de montage corrigé de la pompe d'injection (E<sub>k</sub>) relevée dans le tableau 5 correspondant au code EP.  
Exemple 146,9 mm

**Tableau 5**

E <sub>K</sub> (mm)	Code EP	E <sub>K</sub> (mm)	Code EP	E <sub>K</sub> (mm)	Code EP	E <sub>K</sub> (mm)	Code EP	E <sub>K</sub> (mm)	Code EP
144,5		145,1		145,7	349	146,3	373	146,9	397
144,525		145,125		145,725	350	146,325	374	146,925	398
144,55		145,15		145,75	351	146,35	375	146,95	399
144,575		145,175		145,775	352	146,375	376	146,975	400
144,6		145,2		145,8	353	146,4	377	147,0	401
144,625		145,225		145,825	354	146,425	378	147,025	
144,65		145,25		145,85	355	146,45	379	147,05	
144,675		145,275		145,875	356	146,475	380	147,075	
144,7		145,3		145,9	357	146,5	381	147,1	
144,725		145,325		145,925	358	146,525	382	147,125	
144,75		145,35	335	145,95	359	146,55	383	147,15	
144,775		145,375	336	145,975	360	146,575	384	147,175	
144,8		145,4	337	146,0	361	146,6	385	147,2	
144,825		145,425	338	146,025	362	146,625	386	147,225	
144,85		145,45	339	146,05	363	146,65	387	147,25	
144,875		145,475	340	146,075	364	146,675	388	147,275	
144,9		145,5	341	146,1	365	146,7	389	147,3	
144,925		145,525	342	146,125	366	146,725	390	147,325	
144,95		145,55	343	146,15	367	146,75	391	147,35	
144,975		145,575	344	146,175	368	146,775	392	147,375	
145,0		145,6	345	146,2	369	146,8	393	147,4	
145,025		145,625	346	146,225	370	146,825	394	147,425	
145,05		145,65	347	146,25	371	146,85	395	147,45	
145,075		145,675	348	146,275	372	146,875	396	147,475	

Consulter le tableau indiquant l'indice de longueur de la pompe d'injection (A) (nouvelle pompe d'injection), exemple 133.

La cote de base de la pompe d'injection (L<sub>0</sub>) est indiquée dans le tableau 1, exemple 143 mm.

Calculer l'épaisseur théorique (T<sub>s</sub>) des rondelles d'épaisseur

$$T_s = E_K - (L_0 + A/100)$$

$$T_s = 146,9 \text{ mm} - (143 \text{ mm} + 133/100 \text{ mm})$$

$$T_s = 2,57 \text{ mm}$$

Choisir l'épaisseur des rondelles d'épaisseur (S<sub>s</sub>) selon le tableau 2

$$T_s 2,57 \text{ mm} = S_s \mathbf{2,6 \text{ mm}}$$



**Determinazione dello spessore delle rondelle per l'inizio di mandata nel BFM 1013**  
**Sostituzione della pompa d'iniezione Bosch a cura del service.**  
**Misura base L<sub>0</sub> = 143 mm**

In tale caso non è necessario disporre né della vecchia pompa d'iniezione né del vecchio spessore.

**Esempio:** su un motore BF6M 1013 è necessario sostituire la pompa d'iniezione del cilindro 3.

Procedimento:

rilevare dalla targhetta motore nei riquadri "EP" il codice EP per il cilindro 3, per esempio 397.  
 (sistema di lettura: riquadro 1 = cilindro 1, riquadro 2 = cilindro 2, e così via)

(E<sub>K</sub>)Prendere nota dalla tabella 5 delle dimensioni d'ingombro (E<sub>K</sub>) della pompa d'iniezione in corrispondenza al codice EP, nel nostro caso 146,9 mm.

**Tabella 5**

E <sub>K</sub> (mm)	Codice EP	E <sub>K</sub> (mm)	Codice EP	E <sub>K</sub> (mm)	Codice EP	E <sub>K</sub> (mm)	Codice EP	E <sub>K</sub> (mm)	Codice EP
144,5		145,1		145,7	349	146,3	373	146,9	397
144,525		145,125		145,725	350	146,325	374	146,925	398
144,55		145,15		145,75	351	146,35	375	146,95	399
144,575		145,175		145,775	352	146,375	376	146,975	400
144,6		145,2		145,8	353	146,4	377	147,0	401
144,625		145,225		145,825	354	146,425	378	147,025	
144,65		145,25		145,85	355	146,45	379	147,05	
144,675		145,275		145,875	356	146,475	380	147,075	
144,7		145,3		145,9	357	146,5	381	147,1	
144,725		145,325		145,925	358	146,525	382	147,125	
144,75		145,35	335	145,95	359	146,55	383	147,15	
144,775		145,375	336	145,975	360	146,575	384	147,175	
144,8		145,4	337	146,0	361	146,6	385	147,2	
144,825		145,425	338	146,025	362	146,625	386	147,225	
144,85		145,45	339	146,05	363	146,65	387	147,25	
144,875		145,475	340	146,075	364	146,675	388	147,275	
144,9		145,5	341	146,1	365	146,7	389	147,3	
144,925		145,525	342	146,125	366	146,725	390	147,325	
144,95		145,55	343	146,15	367	146,75	391	147,35	
144,975		145,575	344	146,175	368	146,775	392	147,375	
145,0		145,6	345	146,2	369	146,8	393	147,4	
145,025		145,625	346	146,225	370	146,825	394	147,425	
145,05		145,65	347	146,25	371	146,85	395	147,45	
145,075		145,675	348	146,275	372	146,875	396	147,475	

Identificare sulla nuova pompa d'iniezione il numero caratteristico per la lunghezza (A) della pompa d'iniezione, per esempio 133.

Prendere dalla tabella 1 la misura base (L<sub>0</sub>) della pompa di iniezione, per esempio 143 mm.

Determinare lo spessore teorico (T<sub>s</sub>) della rondella:

$$T_s = EK - (L_0 + A/100)$$

$$T_s = 146,9 \text{ mm} - (143 \text{ mm} + 133/100 \text{ mm})$$

$$T_s = 2,57 \text{ mm}$$

Ricavare dalla tabella 2 lo spessore effettivo della rondella (S<sub>s</sub>):

$$T_s 2,57 \text{ mm} = S_s \mathbf{2,6mm}$$

1 1

In tale caso non è necessario disporre né della vecchia pompa d'iniezione né del vecchio spessore.

**Esempio:** su un motore BF6M 1013 è necessario sostituire la pompa d'iniezione del cilindro 3.

Procedimento:

rilevare dalla targhetta motore nei riquadri "EP" il codice EP per il cilindro 3, per esempio 397.  
 (sistema di lettura: riquadro 1 = cilindro 1, riquadro 2 = cilindro 2, e così via)

(E<sub>K</sub>)Prendere nota dalla tabella 5 delle dimensioni d'ingombro (E<sub>K</sub>) della pompa d'iniezione in corrispondenza al codice EP, nel nostro caso 146,9 mm.

**Tabella 5**

E <sub>K</sub> (mm)	Codice EP	E <sub>K</sub> (mm)	Codice EP	E <sub>K</sub> (mm)	Codice EP	E <sub>K</sub> (mm)	Codice EP	E <sub>K</sub> (mm)	Codice EP
144,5		145,1		145,7	349	146,3	373	146,9	397
144,525		145,125		145,725	350	146,325	374	146,925	398
144,55		145,15		145,75	351	146,35	375	146,95	399
144,575		145,175		145,775	352	146,375	376	146,975	400
144,6		145,2		145,8	353	146,4	377	147,0	401
144,625		145,225		145,825	354	146,425	378	147,025	
144,65		145,25		145,85	355	146,45	379	147,05	
144,675		145,275		145,875	356	146,475	380	147,075	
144,7		145,3		145,9	357	146,5	381	147,1	
144,725		145,325		145,925	358	146,525	382	147,125	
144,75		145,35	335	145,95	359	146,55	383	147,15	
144,775		145,375	336	145,975	360	146,575	384	147,175	
144,8		145,4	337	146,0	361	146,6	385	147,2	
144,825		145,425	338	146,025	362	146,625	386	147,225	
144,85		145,45	339	146,05	363	146,65	387	147,25	
144,875		145,475	340	146,075	364	146,675	388	147,275	
144,9		145,5	341	146,1	365	146,7	389	147,3	
144,925		145,525	342	146,125	366	146,725	390	147,325	
144,95		145,55	343	146,15	367	146,75	391	147,35	
144,975		145,575	344	146,175	368	146,775	392	147,375	
145,0		145,6	345	146,2	369	146,8	393	147,4	
145,025		145,625	346	146,225	370	146,825	394	147,425	
145,05		145,65	347	146,25	371	146,85	395	147,45	
145,075		145,675	348	146,275	372	146,875	396	147,475	

Identificare sulla nuova pompa d'iniezione il numero caratteristico per la lunghezza (A) della pompa d'iniezione, per esempio 133.

Prendere dalla tabella 1 la misura base (L<sub>0</sub>) della pompa di iniezione, per esempio 143 mm.

Determinare lo spessore teorico (T<sub>s</sub>) della rondella:

$$T_s = EK - (L_0 + A/100)$$

$$T_s = 146,9 \text{ mm} - (143 \text{ mm} + 133/100 \text{ mm})$$

$$T_s = 2,57 \text{ mm}$$

Ricavare dalla tabella 2 lo spessore effettivo della rondella (S<sub>s</sub>):

$$T_s 2,57 \text{ mm} = S_s \mathbf{2,6mm}$$



## Korrigiertes Einbaumaß ( $E_k$ ) und EP-Code ermitteln für Bosch Einspritzpumpe.

Bei Austausch von Kurbelgehäuse, Nockenwelle oder Rollenstößel muß das korrigierte Einbaumaß ( $E_k$ ) neu ermittelt und der dazugehörige EP-Code auf dem Firmenschild geändert werden.

Tabellen siehe Seite 1.00.13 und 1.00.15 / 1.00.15.1 / 1.00.17

Berechnungsbeispiel:	BFM 1012				BFM 1013			
Zylinder Nr.	0	0	1	2	0	1	2	3
Lo aus Tabelle 1 mm	<b>109</b>	<b>119</b>			<b>143</b>			
FB Ist gemessen °Kw	8	8			10			
FB Nenn aus Tabelle 1 °Kw	9	9			10			
Vh Korr.faktor aus Tab.1 mm/°Kw	0,1	0,1			0,1			
Vh Nenn aus Tabelle 1 mm	4,63	4,63			5,31			
L gemessen mm	116,26	126,57			152,22			
E1 = FB Ist - FB Nenn °Kw	-1	-1			0			
E2 = E1 x Vh Korrekturfaktor mm	-0,1	-0,1			0			
E3 = E2 + Vh Nenn mm	4,53	4,53			5,31			
$E_k = L - E3$ mm	111,73	122,04			146,91			
$E_k$ symmetrisch gerundet mm	111,725	122,05			146,9			
EP-Code aus Tabelle 3	<b>070</b>							
EP-Code aus Tabelle 4		<b>183</b>						
EP-Code aus Tabelle 5					<b>397</b>			

1 1

Bei Austausch von Kurbelgehäuse, Nockenwelle oder Rollenstößel muß das korrigierte Einbaumaß ( $E_k$ ) neu ermittelt und der dazugehörige EP-Code auf dem Firmenschild geändert werden.

Tabellen siehe Seite 1.00.13 und 1.00.15 / 1.00.15.1 / 1.00.17

Berechnungsbeispiel:	BFM 1012				BFM 1013			
Zylinder Nr.	0	0	1	2	0	1	2	3
Lo aus Tabelle 1 mm	<b>109</b>	<b>119</b>			<b>143</b>			
FB Ist gemessen °Kw	8	8			10			
FB Nenn aus Tabelle 1 °Kw	9	9			10			
Vh Korr.faktor aus Tab.1 mm/°Kw	0,1	0,1			0,1			
Vh Nenn aus Tabelle 1 mm	4,63	4,63			5,31			
L gemessen mm	116,26	126,57			152,22			
E1 = FB Ist - FB Nenn °Kw	-1	-1			0			
E2 = E1 x Vh Korrekturfaktor mm	-0,1	-0,1			0			
E3 = E2 + Vh Nenn mm	4,53	4,53			5,31			
$E_k = L - E3$ mm	111,73	122,04			146,91			
$E_k$ symmetrisch gerundet mm	111,725	122,05			146,9			
EP-Code aus Tabelle 3	<b>070</b>							
EP-Code aus Tabelle 4		<b>183</b>						
EP-Code aus Tabelle 5					<b>397</b>			





## Determining corrected installation dimension ( $E_k$ ) and EP code for Bosch injection pump.

When replacing crankcase, camshaft or roller tappets, the corrected installation dimension ( $E_k$ ) must be determined once again and the relevant EP code on the nameplate must be changed.  
For tables see pages 1.00.13 and 1.00.15 / 1.00.15.1 / 1.00.17

Calculation example:	BFM 1012				BFM 1013			
Cylinder No.	0	0	1	2	0	1	2	3
Lo nom. from table 1 mm	<b>109</b>	<b>119</b>			<b>143</b>			
FB measured °C/A	8	8			10			
FB nom. from table °C/A	9	9			10			
Vh corr.factor from tab.1 mm/°C/A	0.1	0,1			0.1			
Vh nom. from table 1 mm	4.63	4.63			5.31			
L measured mm	116.26	126.57			152.22			
E1 = FB actual - FB nom °C/A	-1	-1			0			
E2 = E1 x Vh corr.factor mm	-0.1	-0.1			0			
E3 = E2 + Vh nom. mm	4.53	4.53			5.31			
EK = L - E3 mm	111.73	122.04			146.91			
$E_k$ symm. rounded mm	111.725	122.05			146.9			
EP code from table 3	<b>070</b>							
EP code from table 4		<b>183</b>						
EP code from table 5					<b>397</b>			

1 1

When replacing crankcase, camshaft or roller tappets, the corrected installation dimension ( $E_k$ ) must be determined once again and the relevant EP code on the nameplate must be changed.  
For tables see pages 1.00.13 and 1.00.15 / 1.00.15.1 / 1.00.17

Calculation example:	BFM 1012				BFM 1013			
Cylinder No.	0	0	1	2	0	1	2	3
Lo nom. from table 1 mm	<b>109</b>	<b>119</b>			<b>143</b>			
FB measured °C/A	8	8			10			
FB nom. from table °C/A	9	9			10			
Vh corr.factor from tab.1 mm/°C/A	0.1	0,1			0.1			
Vh nom. from table 1 mm	4.63	4.63			5.31			
L measured mm	116.26	126.57			152.22			
E1 = FB actual - FB nom °C/A	-1	-1			0			
E2 = E1 x Vh corr.factor mm	-0.1	-0.1			0			
E3 = E2 + Vh nom. mm	4.53	4.53			5.31			
EK = L - E3 mm	111.73	122.04			146.91			
$E_k$ symm. rounded mm	111.725	122.05			146.9			
EP code from table 3	<b>070</b>							
EP code from table 4		<b>183</b>						
EP code from table 5					<b>397</b>			



## Calculer la cote de montage corrigée ( $E_k$ ) et le code EP pour la pompe d'injection Bosch

En cas de changement du carter moteur, de l'arbre à came ou du poussoir à galet recalculer à nouveau la cote de montage corrigée ( $E_k$ ), le code EP se trouvant sur la plaque d'identification du constructeur doit être modifié.  
Tableau voir page 1.00.13 et 1.00.15 / 1.00.15.1 / 1.00.17

Exemple de calcul:	BFM 1012				BFM 1013			
Cylindre no.	0	0	1	2	0	1	2	3
L0 tableau 1 mm	<b>109</b>	<b>119</b>			<b>143</b>			
FB réel mesuré °vil.	8	8			10			
FB nominal indiqué dans le tableau 1 °vil.	9	9			10			
Vh facteur de correction indiqué dans le tableau 1 mm/°vil.	0,1	0,1			0,1			
Vh nominal indiqué dans le tableau 1 mm	4,63	4,63			5,31			
L mesuré mm	116,26	126,57			152,22			
E1 = FB réel - FB nominal °vil.	-1	-1			0			
E2 = E1 x Vh facteur de correction mm	-0,1	-0,1			0			
E3 = E2 + Vh nominal mm	4,53	4,53			5,31			
$E_k = L - E3$ mm	111,73	122,04			146,91			
$E_k$ arrondi symétrique mm	111,725	122,05			146,9			
Code EP tableau 3	<b>070</b>							
Code EP tableau 4		<b>183</b>						
Code EP tableau 5					<b>397</b>			

1 1

En cas de changement du carter moteur, de l'arbre à came ou du poussoir à galet recalculer à nouveau la cote de montage corrigée ( $E_k$ ), le code EP se trouvant sur la plaque d'identification du constructeur doit être modifié.  
Tableau voir page 1.00.13 et 1.00.15 / 1.00.15.1 / 1.00.17

Exemple de calcul:	BFM 1012				BFM 1013			
Cylindre no.	0	0	1	2	0	1	2	3
L0 tableau 1 mm	<b>109</b>	<b>119</b>			<b>143</b>			
FB réel mesuré °vil.	8	8			10			
FB nominal indiqué dans le tableau 1 °vil.	9	9			10			
Vh facteur de correction indiqué dans le tableau 1 mm/°vil.	0,1	0,1			0,1			
Vh nominal indiqué dans le tableau 1 mm	4,63	4,63			5,31			
L mesuré mm	116,26	126,57			152,22			
E1 = FB réel - FB nominal °vil.	-1	-1			0			
E2 = E1 x Vh facteur de correction mm	-0,1	-0,1			0			
E3 = E2 + Vh nominal mm	4,53	4,53			5,31			
$E_k = L - E3$ mm	111,73	122,04			146,91			
$E_k$ arrondi symétrique mm	111,725	122,05			146,9			
Code EP tableau 3	<b>070</b>							
Code EP tableau 4		<b>183</b>						
Code EP tableau 5					<b>397</b>			



## Determinazione delle misure d'ingombro corrette ( $E_k$ ) e del Codice EP per la pompa d'iniezione **Bosch**.

Nel caso di sostituzione dell'incastellatura motore, dell'albero a camme o della punteria a rullo, si deve procedere a calcolare nuovamente le misure d'ingombro corrette ( $E_k$ ), nonché a modificare il relativo codice EP sulla targhetta del motore.

Vedere le tabelle alle pagine 1.00.13 ed 1.00.15 / 1.00.15.1 / 1.00.17

Esempio di calcolo	BFM 1012				BFM 1013			
	0	0	1	2	0	1	2	3
Cilindro nr.								
L0 come da tabella 1 mm	<b>109</b>	<b>119</b>			<b>143</b>			
FB reale misurato °alb.mot.	8	8			10			
FB Nenn aus Tabelle 1 °alb.mot.	9	9			10			
Fatt. corr. Vh da tab.1 mm/°alb.mot.	0,1	0,1			0,1			
Vh nom. da tabella 1 mm	4,63	4,63			5,31			
L misurata mm	116,26	126,57			152,22			
<hr/>								
$E1 = FB_{reale} - FB_{nom.}$ °alb.mot.	-1	-1			0			
$E2 = E1 \times \text{fattore correzione Vh}$ mm	-0,1	-0,1			0			
$E3 = E2 + Vh$ nominale mm	4,53	4,53			5,31			
$E_k = L - E3$ mm	111,73	122,04			146,91			
$E_k$ arrotondato simmetricam mm	111,725	122,05			146,9			
Codice Ep come da tabella 3	<b>070</b>							
Codice Ep come da tabella 4		<b>183</b>						
Codice Ep come da tabella 5					<b>397</b>			

1 1

Nel caso di sostituzione dell'incastellatura motore, dell'albero a camme o della punteria a rullo, si deve procedere a calcolare nuovamente le misure d'ingombro corrette ( $E_k$ ), nonché a modificare il relativo codice EP sulla targhetta del motore.

Vedere le tabelle alle pagine 1.00.13 ed 1.00.15 / 1.00.15.1 / 1.00.17

Esempio di calcolo	BFM 1012				BFM 1013			
	0	0	1	2	0	1	2	3
Cilindro nr.								
L0 come da tabella 1 mm	<b>109</b>	<b>119</b>			<b>143</b>			
FB reale misurato °alb.mot.	8	8			10			
FB Nenn aus Tabelle 1 °alb.mot.	9	9			10			
Fatt. corr. Vh da tab.1 mm/°alb.mot.	0,1	0,1			0,1			
Vh nom. da tabella 1 mm	4,63	4,63			5,31			
L misurata mm	116,26	126,57			152,22			
<hr/>								
$E1 = FB_{reale} - FB_{nom.}$ °alb.mot.	-1	-1			0			
$E2 = E1 \times \text{fattore correzione Vh}$ mm	-0,1	-0,1			0			
$E3 = E2 + Vh$ nominale mm	4,53	4,53			5,31			
$E_k = L - E3$ mm	111,73	122,04			146,91			
$E_k$ arrotondato simmetricam mm	111,725	122,05			146,9			
Codice Ep come da tabella 3	<b>070</b>							
Codice Ep come da tabella 4		<b>183</b>						
Codice Ep come da tabella 5					<b>397</b>			



# Bildzeichenerklärung

## Werkstatthandbuch BFM 1012/E, BFM 1013/E

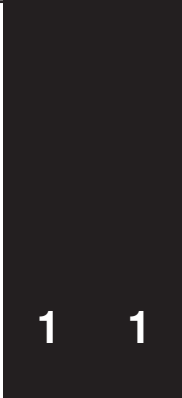

	Zerlegen von Baugruppen		Personenschäden verhüten Hinweis auf Gefahrenstelle
	Zusammenbauen zu einer Baugruppe		Materialschaden verhüten Teilbeschädigung
	Abbauen - Ausbauen behindernder Teile		Unterbauen - Abstützen - Abfangen
	Einbauen - Anbauen Teile, die beim Ab-/ Ausbau hinderten		Einölen
	Achtung, wichtiger Hinweis		Einfetten
	Prüfen - Einstellen z. B. Drehmomente, Maße, Drücke usw.		Markieren vor dem Zerlegen, beachten beim Zusammenbau
	Spezialwerkzeug		Wuchten Ausgleichen von Unwuchten
	Einbaurichtung beachten		Einfüllen - Auffüllen - Nachfüllen z. B. Öl, Kühlwasser usw.
	Kontrollieren - Prüfen Sichtprüfung		Ablassen z. B. Öl, Kühlwasser usw.
	Bedingt wiederverwendbar Bei Bedarf auswechseln		Lösen z. B. Lockern einer Spanneinrichtung
	Beim Zusammenbau immer erneuern		Spannen z. B. Anziehen einer Spanneinrichtung
	Entsichern - Sichern z. B. Splint, Sicherungsblech usw.		Entlüften
	Sichern - Kleben z. B. Dichtmittel flüssig		Spanabhebende Bearbeitung

	Zerlegen von Baugruppen		Personenschäden verhüten Hinweis auf Gefahrenstelle
	Zusammenbauen zu einer Baugruppe		Materialschaden verhüten Teilbeschädigung
	Abbauen - Ausbauen behindernder Teile		Unterbauen - Abstützen - Abfangen
	Einbauen - Anbauen Teile, die beim Ab-/ Ausbau hinderten		Einölen
	Achtung, wichtiger Hinweis		Einfetten
	Prüfen - Einstellen z. B. Drehmomente, Maße, Drücke usw.		Markieren vor dem Zerlegen, beachten beim Zusammenbau
	Spezialwerkzeug		Wuchten Ausgleichen von Unwuchten
	Einbaurichtung beachten		Einfüllen - Auffüllen - Nachfüllen z. B. Öl, Kühlwasser usw.
	Kontrollieren - Prüfen Sichtprüfung		Ablassen z. B. Öl, Kühlwasser usw.
	Bedingt wiederverwendbar Bei Bedarf auswechseln		Lösen z. B. Lockern einer Spanneinrichtung
	Beim Zusammenbau immer erneuern		Spannen z. B. Anziehen einer Spanneinrichtung
	Entsichern - Sichern z. B. Splint, Sicherungsblech usw.		Entlüften
	Sichern - Kleben z. B. Dichtmittel flüssig		Spanabhebende Bearbeitung





# Key to Symbols

## Werkstatthandbuch BFM 1012/E, BFM 1013/E



	Disassembly of assembly groups		Guard against personal injury Indication of hazard
	Reassembly to form assembly group		Guard against material damage Damage to parts
	Remove obstructing parts		Prop up - Support - Hold
	Reinstall - Remount parts which had obstructed disassembly		Oil
	Attention! Important notice!		Grease
	Check - Adjust e. g. torque dimensions, pressures, etc.		Mark before disassembly, observe marks when reassembling
	Special tool		Balance Eliminate any imbalance
	Note direction of installation		Filling - Topping up - Refilling e. g. oil, cooling water, etc.
	Visual inspection		Drain off e. g. oil, cooling water, etc.
	Possibly still serviceable Renew if necessary		Loosen - Release e. g. loosening a clamping device
	Renew at each reassembly		Tighten - Clamp e. g. tightening a clamping device
	Unlock - Lock e. g. split pin, locking plate, etc.		Vent
	Lock - Adhere e. g. with liquid sealant		Machining process

	Disassembly of assembly groups		Guard against personal injury Indication of hazard
	Reassembly to form assembly group		Guard against material damage Damage to parts
	Remove obstructing parts		Prop up - Support - Hold
	Reinstall - Remount parts which had obstructed disassembly		Oil
	Attention! Important notice!		Grease
	Check - Adjust e. g. torque dimensions, pressures, etc.		Mark before disassembly, observe marks when reassembling
	Special tool		Balance Eliminate any imbalance
	Note direction of installation		Filling - Topping up - Refilling e. g. oil, cooling water, etc.
	Visual inspection		Drain off e. g. oil, cooling water, etc.
	Possibly still serviceable Renew if necessary		Loosen - Release e. g. loosening a clamping device
	Renew at each reassembly		Tighten - Clamp e. g. tightening a clamping device
	Unlock - Lock e. g. split pin, locking plate, etc.		Vent
	Lock - Adhere e. g. with liquid sealant		Machining process



# Légende des symboles

## Werkstatthandbuch BFM 1012/E, BFM 1013/E

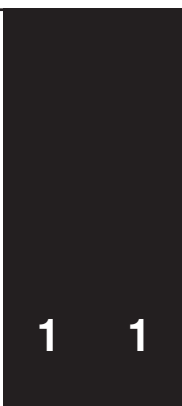

	Déassemblage d'un ensemble constructif		Prévention aux accidents profession attirer l'attention sur un risque eventuel d' accident
	Assemblage des composants d'un ensemble constructif		Prévention à la détérioration de matériels Risque d'endommager des pièces
	Démontage d'éléments entravant l'accès		Monter sur tréteaux - freiner par sabots - immobiliser par un moyen quelconque
	Remontage - Remise en place d'éléments qui entravaient l'accès		Huiler
	Remarque importante!		Graisser employer lubrifiant plastique
	Utilisation impérative p. ex.: couple-moteur, cotes, pressions etc.		Repérage en cours de démontage permet un remontage correct!
	Utilisation impérative d'un outil specialise		Equilibrer éliminer le balourd
	Respecter l'ordre de montage		Premier garnissage - remplissage - garnissage d'appoint p. ex.: Huile eau de refroidissement etc.
	Vérification - Contrôle à vue		Vidanger - soutirer p. ex.: Huile eau de refroidissement etc.
	Réutilisation sous certaines conditions à remplacer, si besoin est		Desserrer p. ex.: desserrage d'un dispositif
	A remplacer systématiquement lors de remontage		Serrer p. ex.: serrage entre un dispositif
	Arracher la goupille - goupiller freiner par tôle-arrêtior		Faire la purge d'air
	Freiner - coller p. ex. avec pâte hermétique, ou frein liquide		Usinage par enlèvement de copeaux

	Déassemblage d'un ensemble constructif		Prévention aux accidents profession attirer l'attention sur un risque eventuel d' accident
	Assemblage des composants d'un ensemble constructif		Prévention à la détérioration de matériels Risque d'endommager des pièces
	Démontage d'éléments entravant l'accès		Monter sur tréteaux - freiner par sabots - immobiliser par un moyen quelconque
	Remontage - Remise en place d'éléments qui entravaient l'accès		Huiler
	Remarque importante!		Graisser employer lubrifiant plastique
	Utilisation impérative p. ex.: couple-moteur, cotes, pressions etc.		Repérage en cours de démontage permet un remontage correct!
	Utilisation impérative d'un outil specialise		Equilibrer éliminer le balourd
	Respecter l'ordre de montage		Premier garnissage - remplissage - garnissage d'appoint p. ex.: Huile eau de refroidissement etc.
	Vérification - Contrôle à vue		Vidanger - soutirer p. ex.: Huile eau de refroidissement etc.
	Réutilisation sous certaines conditions à remplacer, si besoin est		Desserrer p. ex.: desserrage d'un dispositif
	A remplacer systématiquement lors de remontage		Serrer p. ex.: serrage entre un dispositif
	Arracher la goupille - goupiller freiner par tôle-arrêtior		Faire la purge d'air
	Freiner - coller p. ex. avec pâte hermétique, ou frein liquide		Usinage par enlèvement de copeaux



# Spiegazioni dei simboli

## Werkstatthandbuch BFM 1012/E, BFM 1013/E



	Scomporre gruppi di componenti		Prevenire danni alle persone Indicazione di pericolo
	Riassemblare i componenti di un gruppo		Evitare danni ai materiali Danneggiamento di particolari
	Smontare le parti che erano di ostacolo		Puntellare - Supportare -
	Rimontare le parti che sono di ostacolo		Oliare
	Attenzione, indicazione importante		Ingrassare
	Controllare – Regolare per esempio coppie, misure, pressioni, ecc.		Contrassegnare prima dello smontaggio
	Attrezzo speciale		Equilibrare Compensare gli squilibri
	Prestare attenzione al senso di montaggio		Riempire – Rabboccare per esempio olio, liquido refrigerante, ecc.
	Controllare – Provare Controllo visivo		Scaricare per esempio olio, liquido refrigerante, ecc.
	Può venire riutilizzato Se necessario, sostituire		Allentare - Slegare per esempio allentare un dispositivo di bloccaggio
	Sostituire in occasione di ogni riassettaggio		Tendere - Stringere per esempio serrare un dispositivo di bloccaggio
	Sbloccare – Bloccare per esempio copiglia, rosetta di sicurezza, ecc.		Sfiatare - Ventilare
	Fissare, incollare per esempio ermetico liquido		Lavorazione con asportazione di trucioli

	Scomporre gruppi di componenti		Prevenire danni alle persone Indicazione di pericolo
	Riassemblare i componenti di un gruppo		Evitare danni ai materiali Danneggiamento di particolari
	Smontare le parti che erano di ostacolo		Puntellare - Supportare -
	Rimontare le parti che sono di ostacolo		Oliare
	Attenzione, indicazione importante		Ingrassare
	Controllare – Regolare per esempio coppie, misure, pressioni, ecc.		Contrassegnare prima dello smontaggio
	Attrezzo speciale		Equilibrare Compensare gli squilibri
	Prestare attenzione al senso di montaggio		Riempire – Rabboccare per esempio olio, liquido refrigerante, ecc.
	Controllare – Provare Controllo visivo		Scaricare per esempio olio, liquido refrigerante, ecc.
	Può venire riutilizzato Se necessario, sostituire		Allentare - Slegare per esempio allentare un dispositivo di bloccaggio
	Sostituire in occasione di ogni riassettaggio		Tendere - Stringere per esempio serrare un dispositivo di bloccaggio
	Sbloccare – Bloccare per esempio copiglia, rosetta di sicurezza, ecc.		Sfiatare - Ventilare
	Fissare, incollare per esempio ermetico liquido		Lavorazione con asportazione di trucioli

**Prüfen und Einstellen**

**Checking and adjusting**

**Contrôle et réglage**

**Controlli e regolazioni**

**BFM 1012/1013**







**Deutsch**

**Werkstatthandbuch BFM 1012/E, BFM 1013/E**

**2. Prüfen und Einstellen**

**Seite**

Ventilspiel	_____	2.00.01 - 2.00.02
Kompressionsdruck	_____	2.00.03 - 2.00.04
Einspritzventil	_____	2.00.05 - 2.00.07

**English**

**2. Checking and adjusting**

**Page**

Valve clearance	_____	2.00.01 - 2.00.02
Compression pressure	_____	2.00.03 - 2.00.04
Injector	_____	2.00.05 - 2.00.07

**Français**

**2. Contrôle et réglage**

**Page**

Jeu aux soupapes	_____	2.00.01 - 2.00.02
Taux de compression	_____	2.00.03 - 2.00.04
Soupape injectrice	_____	2.00.05 - 2.00.07

**Italiano**

**2. Controlli e regolazioni**

**Pagina**

Gioco delle valvole	_____	2.00.01 - 2.00.02
Pressione di compressione	_____	2.00.03 - 2.00.04
Iniettore	_____	2.00.05 - 2.00.07

English	Français	Italiano
<p><b>Special tool required:</b></p> <p>Turning gear _____ 100 320 Turning gear _____ 100 330</p> <p>The standard valve clearance can be adjusted:</p> <p>with engine cold or warm after cooling down for at least <b>0.5 h</b>. Oil temperature <math>\leq 80^{\circ}\text{C}</math>.</p> <p><b>Note:</b> The valve clearance is to be increased by <b>0.1 mm</b> at every cylinder head gasket renewal. The standard valve clearance is to be adjusted after completion of <b>50-150</b> hours of operation.</p> <p><b>Cylinder head cover and crankcase breather have been removed</b></p> <p>1. Turn engine until valves of cyl. No. 1 overlap.</p> <p><b>See specification data for valve clearance adjustment schematic.</b></p> <p>1.1 If the engine is not freely accessible at the V-belt pulley, turning gear 100 320 may be used with the hydraulic pump removed.</p> <p><b>Note:</b> Valves overlapping means: Exhaust valve about to close. Inlet valve about to open. Neither pushrod can be turned in this position.</p>	<p><b>Outillage usuel:</b></p> <p>Dispositif vireur _____ 100 320 Dispositif vireur _____ 100 330</p> <p>Le réglage standard du jeu aux soupapes est possible:</p> <p>Sur moteur froid ou chaud après une période de refroidissement d'au moins <b>30 minutes</b>. Température de l'huile <math>\leq 80^{\circ}\text{C}</math>.</p> <p><b>Nota:</b> à chaque changement du joint de culasse augmenter le jeu aux culbuteurs de <b>0,1 mm</b>. Après <b>50-150</b> heures de marche procéder au réglage standard des culbuteurs.</p> <p><b>Le cache-culbuteurs et l'évent de carter ont été déposés.</b></p> <p>1. Virer le moteur jusqu'à ce que les soupapes soient en bascule, cyl. no. 1.</p> <p><b>Schéma de réglage du jeu aux culbuteurs voir caractéristiques techniques.</b></p> <p>1.1 Si la poulie à gorge du moteur n'est pas bien accessible, utiliser, après avoir déposé la pompe hydraulique, le dispositif vireur 100 320.</p> <p><b>Nota:</b> le chevauchement des soupapes signifie: soupaped'échappement n'est pas encore fermée et soupape d'admission commence à s'ouvrir. Les deux tiges de culbuteurs ne peuvent plus tourner.</p>	<p><b>Attrezzo speciale:</b></p> <p>Dispositivo di viraggio _____ 100.320 Dispositivo di viraggio _____ 100.330</p> <p>E' possibile eseguire la regolazione standard del gioco delle valvole:</p> <p>sia a motore freddo che a motore caldo dopo un tempo minimo do raffreddamento di <b>0,5 h</b>. Temperatura dell'olio <math>\leq 80^{\circ}\text{C}</math>.</p> <p><b>Nota:</b> Dopo ogni sostituzione della guarnizione della testa, il gioco delle valvole deve venire aumentato di <b>0,1 mm</b>. Dopo <b>50-150</b> h di funzionamento il gioco delle valvole deve venire riportato sul suo valore standard.</p> <p><b>Il coperchio delle punterie e lo sfiato del motore sono smontati.</b></p> <p>1. Virare il motore fino a portare le valvole del cilindro nr. 1 nella posizione di sovrapposizione.</p> <p><b>Schema di registrazione del gioco delle valvole: vedere la tabella dei dati tecnici</b></p> <p>1.1 Nel caso in cui la puleggia della cinghia trapezoidale non sia accessibile, dopo aver smontato la pompa idraulica si può utilizzare il dispositivo di viraggio 100.320.</p> <p><b>Nota:</b> Posizione di sovrapposizione significa che la valvola di scarico non è ancora chiusa, mentre la valvola di aspirazione incomincia ad aprire. In questa posizione le aste delle relative punterie non possono venir fatte girare.</p>

**Deutsch**

**Werkstatthandbuch BFM 1012/E, BFM 1013/E**

**Spezialwerkzeug:**

Durchdrehvorrichtung \_\_\_\_\_ 100 320

Durchdrehvorrichtung \_\_\_\_\_ 100 330

Die Standard-Ventilspieleinstellung ist möglich:

Am kalten- oder am warmen Motor nach einer  
Abkühlzeit von mindestens **0,5 h.**  
Öltemperatur  $\leq 80^{\circ}\text{C}$

**Hinweis:** Bei jedem Zylinderkopf-Dichtungs-  
wechsel ist das Ventilspiel um **0,1 mm**  
zu erhöhen.  
Nach **50-150** Bh ist das Standard-  
Ventilspiel einzustellen.

**Zylinderkopfhaube und  
Kurbelgehäuseentlüftung ist abgebaut.**

1. Motor durchdrehen bis zum Erreichen der  
Ventilüberschneidung, Zyl. Nr. 1

**Ventilspieleinstellschema siehe Techn. Daten**

- 1.1 Ist der Motor an der Keilriemenscheibe nicht  
frei zugänglich, kann bei abgebauter Hydraulikpumpe die Durchdrehvorrichtung 100 320  
verwendet werden.

**Hinweis:** Ventilüberschneidung bedeutet:  
Auslaßventil ist noch nicht geschlos-  
sen, Einlaßventil beginnt zu öffnen.  
Dabei sind beide Stoßstangen nicht  
drehbar.

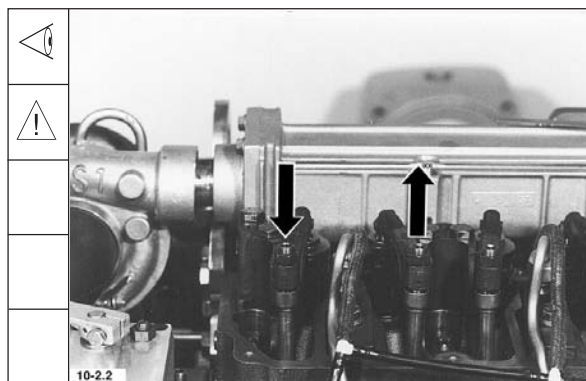
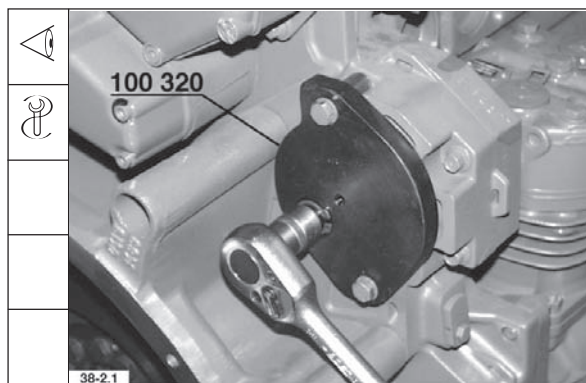
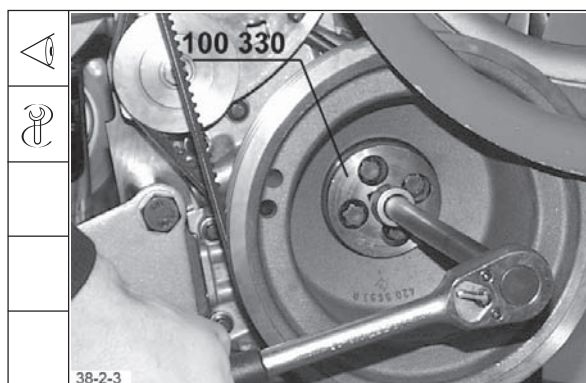

Werkstatthandbuch BFM 1012/E, BFM 1013/E

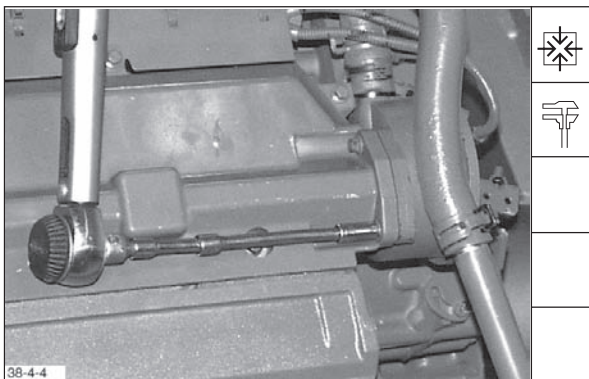
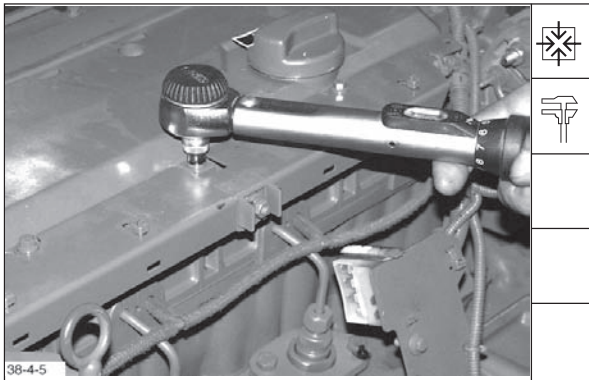
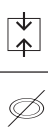
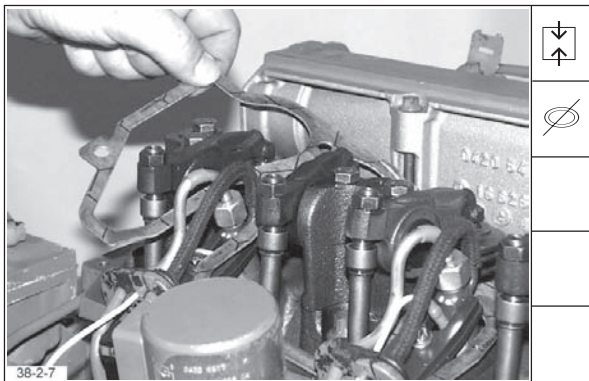
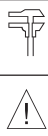
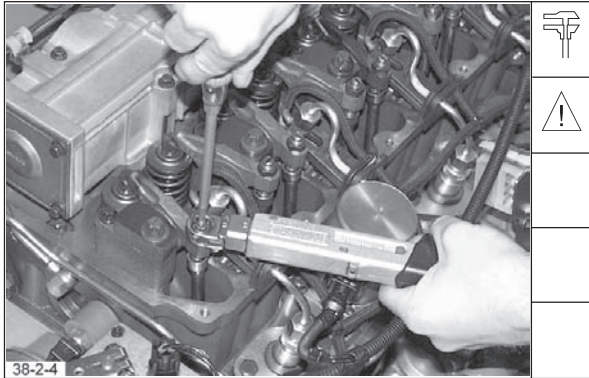

Deutsch

2. Ventilspieleinstellung am entsprechenden Zylinder mit Fühlerlehrenblatt einstellen.

**Hinweis:** Ventilspiel Einlaß: \_\_\_\_\_ **0,3 mm**  
 Ventilspiel Außlaß: \_\_\_\_\_ **0,5 mm**

3. Kontermutter mit einem Drehmoment von **20 ± 2 Nm** festdrehen. Einstellung nochmals mit Fühlerlehrenblatt überprüfen.

4. Dichtung aufsetzen.

5. Zylinderkopfhaube und Abdeckblech montieren. Schrauben mit einem Drehmoment von **9 ± 1 Nm** festdrehen.

6. Kurbelgehäuseentlüftung anbauen. Schrauben mit einem Drehmoment von **9 ± 1 Nm** festdrehen.

English	Français	Italiano
<p>2. Adjust valve clearance on respective cylinder with feeler gauge.</p> <p><b>Note:</b> Inlet valve clearance: — <b>0.3 mm</b> Exhaust valve clearance: _____ <b>0.5 mm</b></p>	<p>2. Régler le jeu aux soupapes au cylindre correspondant avec une jauge d'épaisseur.</p> <p><b>Nota:</b> Jeu soupape ADM: — <b>0,3 mm</b> Jeu soupape ECH: — <b>0,5 mm</b></p>	<p>2. Facendo uso di uno spessimetro, effettuare la regolazione del gioco delle valvole del cilindro corrispondente</p> <p><b>Nota:</b> gioco valvole: aspirazione: _____ <b>0,3 mm</b> scarico: _____ <b>0,5 mm</b></p>
<p>3. Tighten locknut with a torque of <b>20 ± 2 Nm</b>. Recheck the adjustment with feeler gauge.</p>	<p>3. Serrer le contre-écrou au couple de <b>20 ± 2 Nm</b>. Effectuer un nouveau contrôle du serrage avec une jauge d'épaisseur.</p>	<p>3. Bloccare il controdado con una coppia di serraggio di <b>20 ± 2 Nm</b>. Controllare ancora una volta con lo spessimetro</p>
<p>4. Position gasket in place.</p>	<p>4. Mettre en place le joint.</p>	<p>4. Sistemare la guarnizione.</p>
<p>5. Fit cylinder head cover and cover plate. Tighten bolts with a torque of <b>9 ± 1 Nm</b>.</p>	<p>5. Monter le cache-culbuteurs et la tôle de recouvrement. Serrer les vis au couple de <b>9 ± 1 Nm</b>.</p>	<p>5. Montare il coperchio delle punterie e la lamiera di copertura. Bloccare le viti con una coppia di serraggio di <b>9 ± 1 Nm</b>.</p>
<p>6. Fit crankcase breather. Tighten bolts with a torque of <b>9 ± 1 Nm</b>.</p>	<p>6. Monter l'évent de carter. Serrer les vis au couple de <b>9 ± 1 Nm</b>.</p>	<p>6. Rimontare lo sfiato del motore. Bloccare le viti con una coppia di serraggio di <b>9 ± 1 Nm</b>.</p>

**English**

**Commercial tools required:**

Compression tester \_\_\_\_\_ 8005  
Torx tool kit \_\_\_\_\_ 8189

**Special tool required:**

Connector \_\_\_\_\_ 100 110

**Injectors have been removed, valve clearance has been checked.**

1. Insert connector with new special seal.

2. Fit clamping pad. Tighten bolt.

3. If necessary, screw on adapter for connector.

**Français**

**Outillage usuel:**

Compressiomètre \_\_\_\_\_ 8005  
Jeu d'outils Torx \_\_\_\_\_ 8189

**Outil spécial:**

Pièce de raccordement \_\_\_\_\_ 100 110

**Les injecteurs ont été déposés et le jeu aux soupapes contrôlé.**

1. Mettre en place la pièce de raccordement avec un joint spécial neuf.

2. Placer la griffe de serrage et serrer le boulon.

3. Si nécessaire mettre en place l'adaptateur de la pièce de raccordement.

**Italiano**

**Attrezzi comuni:**

Misuratore della pressione di compressione \_\_\_\_\_ 8005  
Kit di attrezzi \_\_\_\_\_ Torx 8189

**Attrezzi speciali:**

Raccordo \_\_\_\_\_ 100 110

**Gli iniettori sono stati smontati ed il gioco delle valvole controllato**

1. Montare il raccordo munito della speciale guarnizione.

2. Applicare la staffa di serraggio e serrare a fondo la vite.

3. Se necessario, avvitare l'adattatore per il raccordo.

**Deutsch**

**Werkstatthandbuch BFM 1012/E, BFM 1013/E**

**Handelsübliche Werkzeuge:**

Kompressionsdruckprüfer \_\_\_\_\_ 8005  
Torx-Werkzeugsatz \_\_\_\_\_ 8189

**Spezialwerkzeug:**

Anschlußstück \_\_\_\_\_ 100 110

**Einspritzventile sind ausgebaut, Ventilspiel ist kontrolliert**

1. Anschlußstück mit Spezialdichtung einsetzen
2. Spannpratze aufsetzen. Schraube festdrehen.
3. Falls notwendig Adapter für Anschlußstück aufschrauben.

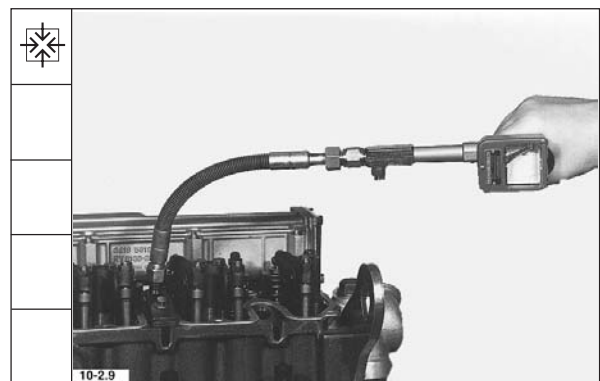
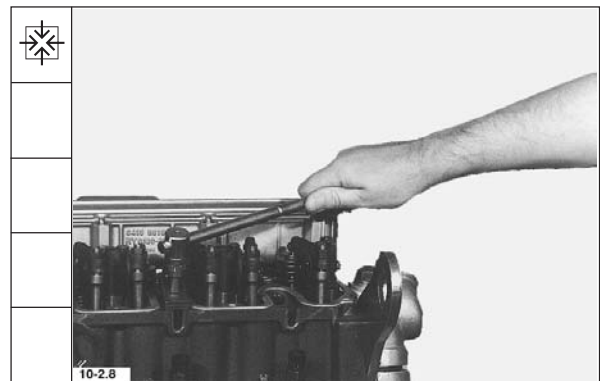
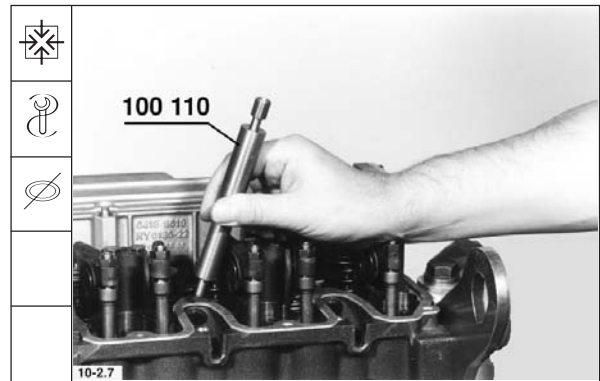



Werkstatthandbuch BFM 1012/E, BFM 1013/E

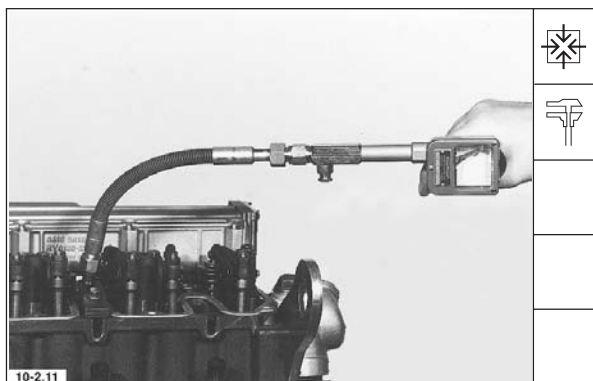

10-2.11

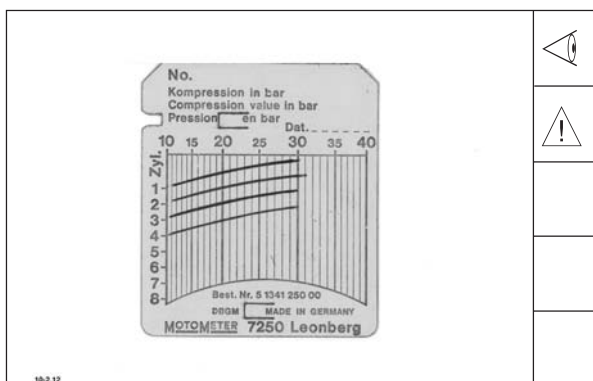

10-2.12



2

Deutsch

4. Kompressionsdruckprüfer anschließen.  
Motor mit Starter durchdrehen.  
Kompressionsdruck: BFM 1012 **28-33 bar**  
BFM 1013 **30-38 bar**

Der gemessene Kompressionsdruck ist abhängig von der Anlaßdrehzahl während des Meßvorganges und der Höhenlage des Motor-aufstellortes.

Grenzwerte sind daher nicht genau festlegbar. Empfohlen wird die Kompressionsdruckmessung nur als Vergleichsmessung aller Zylinder eines Motors untereinander anzusehen. Sind mehr als **15%** Abweichung ermittelt worden, sollte durch die Demontage der betroffenen Zylindereinheit die Ursache ermittelt werden.

**Hinweis:** Einspritzventile mit neuen Spezialdichtungen einsetzen. Spannpratzen aufsetzen und Schrauben lose einschrauben.  
**Neue** Einspritzleitungen anbauen. Überwurfmuttern fingerfest aufschrauben.  
Die Dichtkoneen müssen exakt aufeinander-sitzen.  
**Ein Nachbiegen ist nicht zulässig. Die Einspritzleitungen dürfen nicht 2x verwendet werden.**  
Schrauben der Spannpratzen mit einem Drehmoment von **16 + 5 Nm** festdrehen. Überwurfmuttern der Einspritzleitungen an den Einspritzpumpen und Einspritzventilen mit einem Drehmoment von ca. **5 Nm** vorspannen. Danach die Überwurfmuttern mit einem Drehmoment von **25 + 3,5 Nm** festdrehen.  
**Leckölleitungen sind grundsätzlich zu erneuern.**  
Zylinderkopfhaube mit einem Drehmoment von **9 ± 1 Nm** festdrehen.



English	Français	Italiano
<p>4. Connect compression tester. Turn engine with starter.</p>	<p>4. Brancher le compresseur.</p>	<p>4. Collegare il misuratore della pressione di compressione. Far girare il motore per mezzo del motorino d'avviamento.</p>
<p>Compression pressure:                      BFM 1012           <b>28-33 bar</b>                      BFM 1013           <b>30-38 bar</b></p>	<p>Pression de compression:                      BFM 1012           <b>28-33 bars</b>                      BFM 1013           <b>30-38 bars</b></p>	<p>Valore della pressione:                      BFM 1012           <b>28-33 bar</b>                      BFM 1013           <b>30-38 bar</b></p>
<p>The measured compression pressure is dependent on the starting speed during the measuring process and also on the altitude of the engine site. Therefore it is difficult to specify precise limit values. It is recommended to use the compression pressure measurement only for comparison of compression pressures of all cylinders in one engine. If a difference in pressure in excess of <b>15%</b> is determined, the cylinder unit concerned should be dismantled to establish the cause.</p>	<p>Le taux de compression mesuré dépend de la vitesse de démarrage pendant le relevé des mesures, et du niveau du lieu d'implantation du moteur. Des valeurs limites précises ne peuvent donc pas être fixées. Il est conseillé de considérer la mesure du taux de compression uniquement comme mesure comparative pour tous les cylindres d'un moteur. En cas d'écart supérieur à <b>15%</b>, la cause pourra être déterminée en démontant l'unité cylindre concernée.</p>	<p>Il valore della pressione di compressione misurato dipende dalla velocità d'avviamento durante la misurazione e dall'altitudine del luogo in cui si effettua il controllo. Per questa ragione non è possibile fissare dei valori limite. Si consiglia pertanto di considerare tale misurazione unicamente come un paragone tra i singoli cilindri dello stesso motore. Se però si riscontrano degli scarti superiori al <b>15%</b> se ne deve stabilire la causa dopo avere smontato l'unità cilindro interessata.</p>
<p><b>Note:</b> Fit injectors with new special seals. Position clamping pads and start bolts. Fit <b>new</b> injection lines. Screw on cap nuts fingertight. The sealing cones must match precisely.  <b>Rebending is not permissible. The injection lines may not be used twice.</b>                      Tighten bolts of clamping pads with a torque of <b>16 + 5 Nm</b>. Preload cap nuts of injection lines on injection pumps and injectors with a torque of approx. <b>5 Nm</b>. Thereafter tighten cap nuts with a torque of <b>25 + 3.5 Nm</b>.  <b>Leakage fuel lines must always be renewed.</b>                      Tighten cylinder head cover with a torque of <b>9 ± 1 Nm</b>.</p>	<p><b>Nota:</b> Utiliser des injecteurs avec de nouveaux joints spéciaux. Placer les griffes de serrage et serrer les vis sans serrer. Monter des conduites d'injection <b>neuves</b>. Serrer les écrous-raccords modérément à la main. Les cônes d'étanchéité doivent parfaitement correspondre.  <b>Un recintringe n'est pas autorisé. Ne jamais utiliser deux fois les conduites d'injection.</b>                      Bloquer les vis des griffes de serrage au couple de <b>16 + 5 Nm</b>. Préserrer les écrous-raccords des conduites d'injection et injecteurs au couple d'environ <b>5 Nm</b>. Ensuite bloquer les écrous-raccords au couple de <b>25 + 3,5 Nm</b>.  <b>Toujours renouveler les conduites de retour des fuites.</b>                      Bloquer le cache-culasse au couple de <b>9 ± 1 Nm</b>.</p>	<p><b>Nota:</b> Montare gli iniettori munendoli di nuove guarnizioni speciali. Applicare le staffe di serraggio ed avvitare le viti lasciandole lente. Montare <b>nuove</b> tubazioni di iniezione. Avvitare a mano le viti a risvolto, lasciandole lente. Le tenute coniche devono accoppiarsi esattamente tra di loro. <b>Non è ammesso modificare le curve esistenti od eseguirne di nuove. Le tubazioni di iniezione non possono venire utilizzate più di una volta.</b>                      Bloccare le viti delle staffe di serraggio con una coppia di <b>16 + 5 Nm</b>. Precaricare i dadi a risvolto tra le tubazioni di iniezione e le pompe di iniezione, nonché gli iniettori con una coppia di circa <b>5 Nm</b>. Serrare a fondo quindi i dadi a risvolto con una coppia di <b>25+3,5 Nm</b>.  <b>Le tubazioni di ricupero del combustibile devono di norma venire rinnovate.</b>                      Bloccare il coperchio delle punterie con una coppia di <b>9 ± 1 Nm</b>.</p>



English	Français	Italiano
<b>Commercial tools required:</b>	<b>Outillage usue:</b>	<b>Attrezzi comuni:</b>
Nozzle tester _____ 8008 Long socket a/flats 15 _____ 8012	Banc d'essais d'injecteurs _____ 8008 Longue clé à douille de 15 _____ 8012	Banco prova iniettori _____ 8008 Chiave a bussola SW15 _____ 8012
<b>Special tool required:</b>	<b>Outillage spécial:</b>	<b>Attrezzo speciale</b>
Assembly tool _____ 110 110	Dispositif de montage _____ 110 110	Dispositivo di montaggio _____ 110 110
<b>Note:</b> Utmost cleanliness must be ensured when working on the injection equipment. For testing the injector use only pure test oil to ISO 4113 or clean diesel fuel.	<b>Nota:</b> Tous les travaux à effectuer sur les injecteurs doivent être réalisés dans de parfaites conditions de propreté. Pour contrôler les injecteurs n'utiliser que du gazole d'essai pur selon ISO 4113 ou du combustible diesel parfaitement propre.	<b>Nota:</b> Durante i lavori sul sistema di iniezione ci si deve preoccupare di usare la massima pulizia. Per il controllo degli iniettori far uso soltanto di puro olio di prova ISO 4113 oppure di combustibile pulito.
<b>Caution</b>	<b>Attention</b>	<b>Attenzione</b>
Beware of injection nozzle fuel jet. The fuel penetrates deeply into the skin tissue and may cause blood poisoning.	Tenir les mains à l'écart des jets de gazole, la force de pénétration de ceux-ci est telle qu'ils peuvent créer des blessures graves et provoquer un empoisonnement du sang.	Tenere lontane le mani dal getto dell'iniettore. Il combustibile penetra profondamente nei tessuti e può provocare un avvelenamento del sangue.
1. Connect injector to nozzle tester.	1. Monter l'injecteur sur la pompe d'essais d'injecteurs.	1. Montare l'iniettore sull'apparecchio di prova per i polverizzatori.
<b>2. Checking opening pressure</b>	<b>2. Contrôle de la pression d'ouverture</b>	<b>2. Controllo della pressione di apertura.</b>
With pressure gauge switched on, slowly press down lever of nozzle tester. The pressure at which the gauge pointer stops or suddenly drops, is the opening pressure. Opening pressure check value for possible reuse: BFM 1012 <b>250 + 8 bar</b> BFM 1013 <b>275 + 8 bar.</b>	Le manomètre étant branché, appuyer lentement sur le levier de la pompe d'essai d'injecteurs. La pression à laquelle l'aiguille s'arrête ou chute brusquement, est la pression maxi ou pression d'ouverture. Valeur de contrôle de pression d'ouverture pour réutilisation: BFM 1012 <b>250 + 8 bars</b> BFM 1013 <b>275 + 8 bars.</b>	Dopo avere collegato il manometro, spingere in basso lentamente la leva dell'apparecchio di prova. La pressione alla quale la lancetta si arresta oppure torna indietro improvvisamente rappresenta la pressione di apertura..  Pressione d'apertura: BFM 1012 <b>250 + 8 bar</b> BFM 1013 <b>275 + 8 bar</b>

**Deutsch**

**Werkstatthandbuch BFM 1012/E, BFM 1013/E**

**Handelsübliche Werkzeuge:**

Düsenprüfgerät \_\_\_\_\_ 8008  
Lange Stecknuß SW15 \_\_\_\_\_ 8012

**Spezialwerkzeug**

Montagevorrichtung \_\_\_\_\_ 110 110

**Hinweis:** Bei Arbeiten an der Einspritzaus-  
rüstung auf größte Sauberkeit  
achten. Zur Prüfung der Einspritz-  
ventile nur reines Prüföl nach  
ISO 4113 oder sauberen Diesel-  
kraftstoff verwenden.

**Achtung**

Hände weg vom Düsenstrahl. Der Kraftstoff  
dringt tief in das Fleisch ein und kann zur  
Blutvergiftung führen.

1. Einspritzventil an das Düsenprüfgerät  
anbauen.

**2. Prüfung des Öffnungsdruckes**

Hebel des Düsenprüfgerätes bei  
zugeschaltetem Manometer langsam  
niederdrücken. Der Druck bei dem der Zei-  
ger stehen bleibt oder plötzlich abfällt, ist  
der Öffnungsdruck.

Öffnungsdruck: BFM 1012 **250 + 8 bar**  
BFM 1013 **275 + 8 bar**



Werkstatthandbuch BFM 1012/E, BFM 1013/E

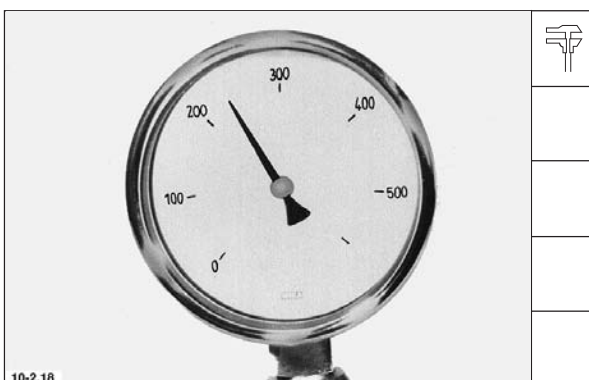
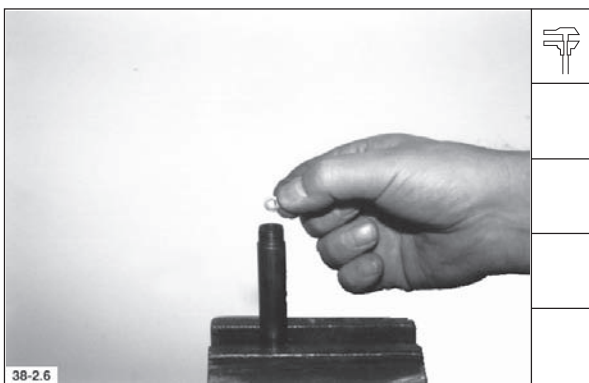
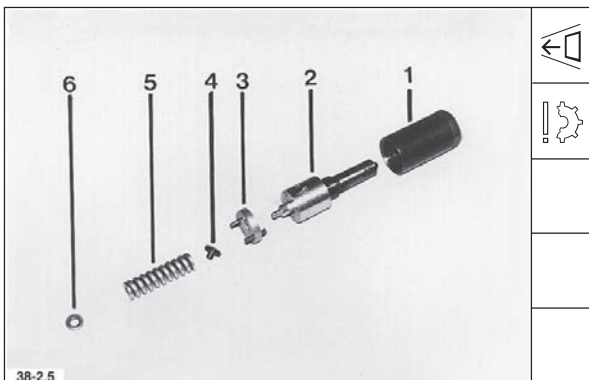
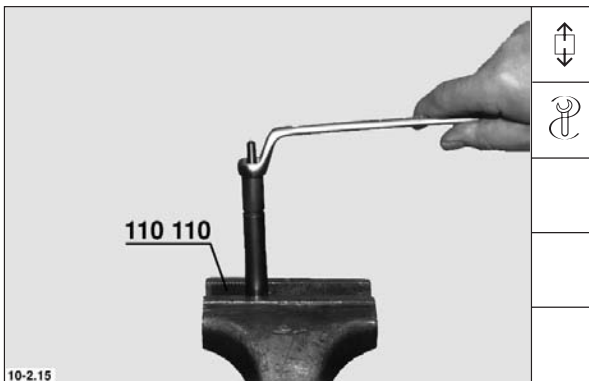

2

Deutsch

**3. Einstellen des Öffnungsdruckes am Einspritzventil**

Überwurfmutter abschrauben, alle Teile ausbauen.

**Folge der Einzeldemontage**

1. Überwurfmutter
2. Einspritzdüse
3. Zwischenstück
4. Druckbolzen
5. Druckfeder
6. Ausgleichscheibe

4. Durch Auswahl der erforderlichen Scheibe Druck einstellen. Stärkere Scheibe ergibt höheren Öffnungsdruck. Einspritzventil zusammenbauen. Überwurfmutter mit einem Drehmoment von **40 - 50 Nm** festdrehen. Einspritzventil auf dem Düsenprüfgerät erneut prüfen.

**5. Prüfung auf Dichtheit**

Düse und Düsenhalter abtrocknen - mit Luft trockenblasen. Handhebel des Prüfgerätes langsam niederdrücken, bis ca. **20 bar** unterhalb des vorher abgelesenen Öffnungsdruckes erreicht werden.

English	Français	Italiano
<p><b>3. Adjusting the opening pressure on the injector</b></p> <p>Unscrew cap nut and remove all parts.</p>	<p><b>3. Tarage de la pression d'ouverture sur injecteur</b></p> <p>Dévisser l'écrou-raccord et déposer toutes les pièces.</p>	<p><b>3. Regolazione della pressione d'apertura dell'inietttore</b></p> <p>Svitare il dado a risvolto e smontare tutti i componenti.</p>
<p><b>Sequence of parts disassembly</b></p> <ol style="list-style-type: none"> <li>1. Cap nut</li> <li>2. Injection nozzle</li> <li>3. Adapter</li> <li>4. Thrust pin</li> <li>5. Compression spring</li> <li>6. Shim</li> </ol>	<p><b>Suite du démontage des pièces</b></p> <ol style="list-style-type: none"> <li>1. Ecrou-raccord</li> <li>2. Injecteur</li> <li>3. Élément intermédiaire</li> <li>4. Tige poussoir</li> <li>5. Ressort</li> <li>6. Rondelle d'épaisseur</li> </ol>	<p><b>Sequenza di smontaggio dei singoli componenti</b></p> <ol style="list-style-type: none"> <li>1. Dado a risvolto</li> <li>2. Polverizzatore</li> <li>3. Piattello intermedio</li> <li>4. Perno</li> <li>5. Molla di compressione</li> <li>6. Rondella di spessore</li> </ol>
<p>4. Adjust pressure by selecting appropriate shim. A thicker shim increases the opening pressure. Tighten cap nut with a torque of <b>40 - 50 Nm</b>. Recheck injector on nozzle tester.</p>	<p>4. Régler la pression en prenant le nombre de rondelles nécessaires. Des rondelles plus épaisses entraînent une pression d'ouverture plus grande. Remonter l'injecteur. Serrer l'écrou-raccord au couple de <b>40 - 50 Nm</b>. Contrôler l'injecteur à nouveau à l'aide de la pompe d'essai d'injecteurs.</p>	<p>4. Regolare la pressione scegliendo le rondelle necessarie. Con una rondella di maggior spessore si ottiene una pressione più alta. Riasssemblare l'inietttore. Serrare a fondo il dado a risvolto con una coppia di <b>40-50 Nm</b>. Controllare nuovamente l'inietttore al banco prova.</p>
<p><b>5. Checking for tightness</b></p> <p>Dry nozzle and nozzle holder - blow out with compressed air. Press down handlever of tester until a pressure of up to about <b>20 bar</b> below the previous opening pressure reading is attained.</p>	<p><b>5. Contrôle de l'étanchéité</b></p> <p>Sécher l'injecteur et le porte-injecteur par jet d'air. Appuyer lentement sur le levier de la pompe d'essai jusqu'à obtention d'environ <b>20 bars</b> en-dessous de la pression d'ouverture lue auparavant.</p>	<p><b>5. Controllo della tenuta</b></p> <p>Con un getto d'aria asciutta asciugare il polverizzatore ed il porta-polverizzatore. Spingere lentamente in basso la leva dell'apparecchio di prova fino a raggiungere circa <b>20 bar</b> al di sotto della pressione di apertura letta precedentemente.</p>



English	Français	Italiano
<p>6. Nozzle is tight if there is no dripping within a period of <b>10</b> seconds.</p> <p>7. In case of a drip, the injector must be dismantled and cleaned to remedy the leak. If this does not cure the leak, the injector must be replaced.</p> <p>Reworking is not permissible.</p>	<p>6. L'injecteur est étanche lorsqu'il ne goutte plus durant <b>10</b> secondes.</p> <p>7. Si l'injecteur goutte, le déposer et le nettoyer pour supprimer le manque d'étanchéité. En cas d'échec, remplacer l'injecteur.</p> <p>Ne jamais rectifier l'injecteur.</p>	<p>6. Il polverizzatore deve ritenersi stagno se nel tempo di <b>10</b> secondi non lascia cadere nessuna goccia.</p> <p>7. Se cade anche una sola goccia, dopo aver smontato completamente l'iniettore se ne devono pulire accuratamente tutti i suoi componenti. Se malgrado ciò il polverizzatore continua a perdere sarà necessario sostituirlo.</p> <p>Non è ammesso tentare di rettificare i componenti dell'iniettore.</p>
<p><b>8. Buzzing and spray pattern test</b></p>	<p><b>8. Contrôle du crissement caractéristique de l'injecteur</b></p>	<p><b>8. Controllo del getto e del ruggio</b></p>
<p>Switch off pressure gauge of tester.</p> <p>The buzzing test permits an audible check of the ease of movement of the nozzle needle in the nozzle body. New injectors emit a different buzzing sound as compared to used injectors. It deteriorates due to wear in the needle seat area. If an injection nozzle does not buzz despite cleaning, it must be renewed.</p> <p>A used injector should buzz clearly during rapid actuation of the handlever, while exhibiting a well atomized spray pattern. The spray pattern may differ noticeably from that of a new injector.</p>	<p>Débrancher le manomètre de la pompe d'essai.</p> <p>Le contrôle du crissement permet un contrôle audible de l'injecteur dont l'aiguille doit retomber d'elle-même dans son logement. Les injecteurs neufs présentent par rapport aux injecteurs usagés un crissement différent. L'usure se produisant au niveau du siège de l'aiguille entraîne une dégradation du crissement. Si, après nettoyage, l'injecteur refuse de crisser, il faut le remplacer.</p> <p>Un injecteur usagé doit, après actionnement rapide du levier de commande, émettre un crissement audible et pulvériser de manière bien homogène. La forme du jet peut alors, à la différence d'un injecteur neuf, être tout à fait différente.</p>	<p>Disinserire il manometro dall'apparecchio di prova.</p> <p>La prova del ruggio consente un controllo acustico circa la facilità di movimento dell'ago del polverizzatore nella sua sede. Un iniettore nuovo produce un ruggio diverso da quello prodotto da un iniettore usato. Tale cambiamento è dovuto all'usura che ha luogo nella zona della sede dell'ago del polverizzatore. Se, dopo averne eseguita la pulizia, un polverizzatore continua a non ruggiare sarà necessario sostituirlo.</p> <p>Azionando velocemente la leva del banco prova, un iniettore usato deve ruggiare in modo udibile ed emettere contemporaneamente un getto perfettamente nebulizzato. L'aspetto del getto può comunque essere sensibilmente diverso da quello di un iniettore nuovo.</p>

**Deutsch**

**Werkstatthandbuch BFM 1012/E, BFM 1013/E**

6. Düse ist dicht, wenn innerhalb **10** Sekunden kein Tropfen abfällt.

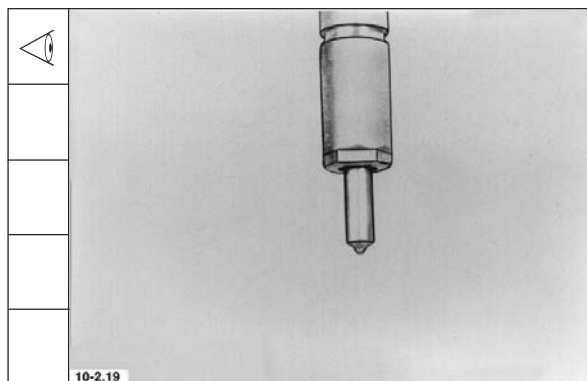

7. Fällt ein Tropfen ab, ist das Einspritzventil zu zerlegen und die Undichtigkeit durch Reinigen zu beseitigen. Ist das nicht erfolgreich, muß die Einspritzdüse erneuert werden.

Nacharbeit ist nicht zulässig.

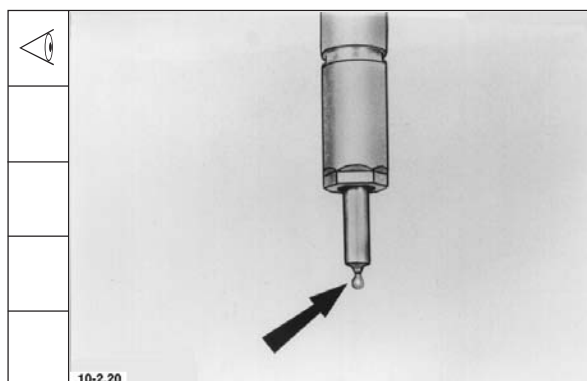

**8. Schnarr- und Strahlprüfung**

Manometer des Prüfgerätes abschalten.

Die Schnarrprüfung ermöglicht eine hörbare Prüfung der Leichtgängigkeit der Düsennadel im Düsenkörper. Neue Einspritzventile haben gegenüber gebrauchten ein geändertes Schnarrverhalten. Durch Verschleiß im Nadelsitzbereich verschlechtert es sich. Schnarrt eine Einspritzdüse trotz Reinigung nicht, muß sie durch eine neue ersetzt werden.

Ein gebrauchtes Einspritzventil muß bei schneller Hebel Tätigkeit hörbar schnarren und dabei gut zerstäubt abspritzen. Das Strahlbild kann dabei gegenüber dem eines neuen Einspritzventils deutlich unterschiedlich sein.







**Bauteile instand setzen**

**Repair of components**

**Mise en état des composants**

**Riparazione di componenti**

**BFM 1012/1013**



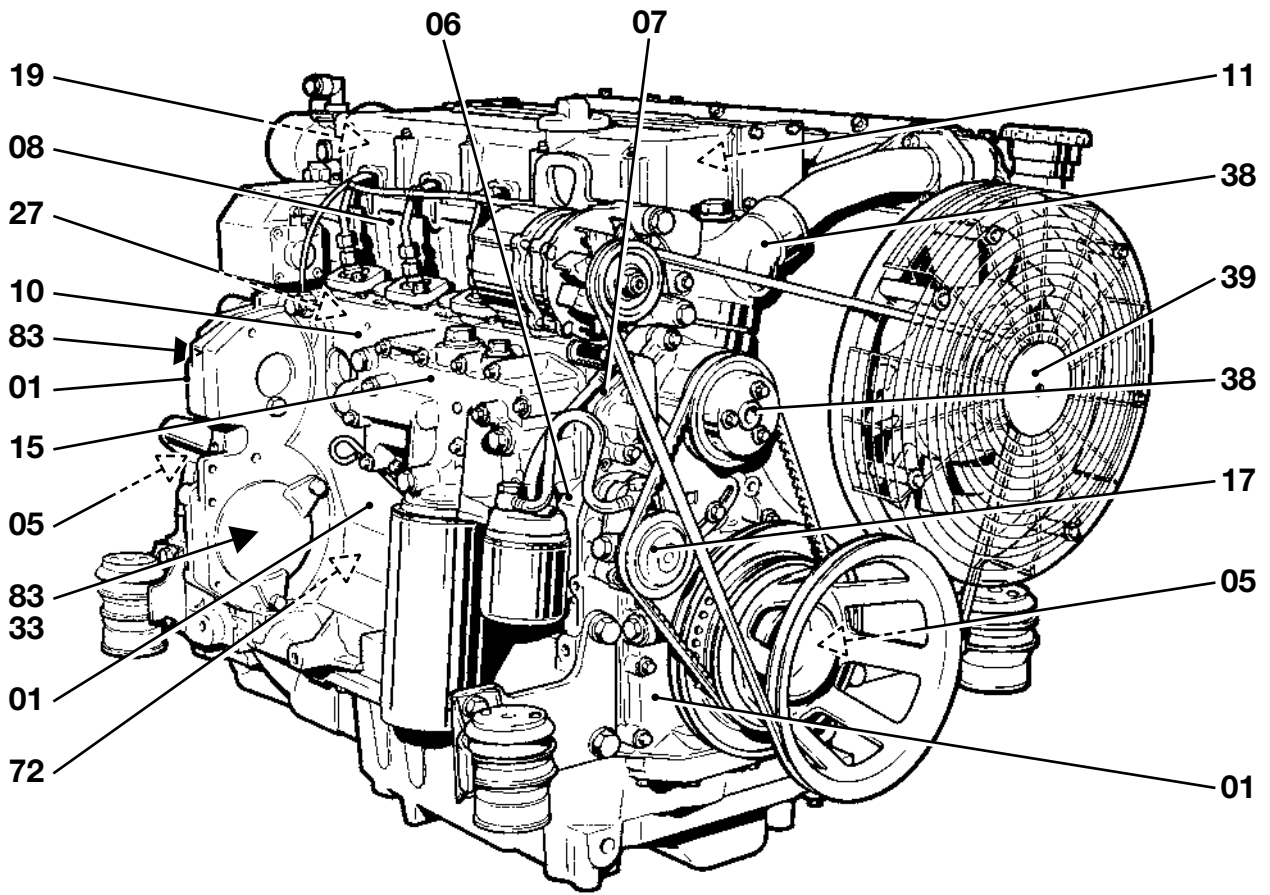

**Werkstatthandbuch BFM 1012/E, BFM 1013/E**

**Deutsch**

**3. Bauteile instandsetzen**

<b>Baugruppe</b>	<b>Benennung</b>	<b>Seite</b>
01	Zylinderkurbelgehäuse	3.01.01 - 3.01.11
01	Vorderer Deckel/Schmierölpumpe	3.01.15 - 3.01.17
01	Räderkasten	3.01.21 - 3.01.22
05	Kurbelwelle	3.05.25 - 3.05.28
05	Starterzahnkranz/Schwungrad	3.05.31
06	Pleuelstange	3.06.35 - 3.06.40
07	Kolben	3.07.43 - 3.07.45
08	Zylinderkopf	3.08.49 - 3.08.54
10	Nockenwelle	3.10.57
11	Kipphebelbock	3.11.61
15	Schmierölkühler	3.15.65 - 3.15.69
17	Kraftstoffpumpe	3.17.73
19	Einspritzventil	3.19.77 - 3.19.79
27	Regelstange	3.27.83 - 3.27.84
33	Luftpresser	3.33.87
38	Thermostat	3.38.91
38	Kühlflüssigkeitspumpe	3.38.95
39	Kühlgebläse	3.39.99 - 3.39.103
72	Massenausgleichswelle	3.72.107
83	Hydraulikpumpenantrieb	3.83.111 - 3.83.113
83	Hydraulikpumpe mit Befestigungsflansch	3.83.117 - 3.83.118

**English**

**3. Repair of components**

<b>Assembly Group</b>	<b>Description</b>	<b>Page</b>
01	Crankcase w. integrated cylinder liners	3.01.01 - 3.01.11
01	Front cover/lube oil pump	3.01.15 - 3.01.17
01	Timing chest	3.01.21 - 3.01.22
05	Crankshaft	3.05.25 - 3.05.28
05	Starter ring gear/flywheel	3.05.31
06	Connecting rod	3.06.35 - 3.06.40
07	Piston	3.07.43 - 3.07.45
08	Cylinder head	3.08.49 - 3.08.54
10	Camshaft	3.10.57
11	Rocker arm	3.11.61
15	Lube oil cooler	3.15.65 - 3.15.69
17	Fuel pump	3.17.73
19	Injector	3.19.77 - 3.19.79
27	Control rod	3.27.83 - 3.27.84
33	Air compressor	3.33.87
38	Thermostat	3.38.91
38	Coolant pump	3.38.95
39	Fan drive	3.39.99 - 3.39.103
72	Mass balancing shaft	3.72.107
83	Hydraulic pump drive	3.83.111 - 3.83.113
83	Hydraulic pump w. fastening flange	3.83.117 - 3.83.118

**Werkstatthandbuch BFM 1012/E, BFM 1013/E**

**Français**

**3. Mise en état des composants**

<b>Groupe</b>	<b>Désignation</b>	<b>Page</b>
01	Bloc moteur	3.01.01 - 3.01.11
01	Couvercle avant/pompe à huile	3.01.15 - 3.01.17
01	Carter de distribution	3.01.21 - 3.01.22
05	Vilebrequin	3.05.25 - 3.05.28
05	Couronne du démarreur/volant moteur	3.05.31
06	Bielle	3.06.35 - 3.06.40
07	Piston	3.07.43 - 3.07.45
08	Culasse	3.08.49 - 3.08.54
10	Arbre à cames	3.10.57
11	Support de culbuteurs	3.11.61
15	Radiateur à huile	3.15.65 - 3.15.69
17	Pompe à combustible	3.17.73
19	Injecteur	3.19.77 - 3.19.79
27	Crémaillère	3.27.83 - 3.27.84
33	Compresseur d'air	3.33.87
38	Thermostat	3.38.91
38	Pompe à eau de refroidissement	3.38.95
39	Soufflante de refroidissement	3.39.99 - 3.39.103
72	Arbre à masses d'équilibrage	3.72.107
83	Entraînement pompe hydraulique	3.83.111 - 3.83.113
83	Pompe hydraulique avec bride de fixation	3.83.117 - 3.83.118

**Italiano**

**3. Riparazione dei componenti**

<b>Gruppo costruttivo</b>	<b>Descrizione</b>	<b>Pagina</b>
01	Incastellatura del motore	3.01.01 - 3.01.11
01	Coperchio anteriore/Coppa dell'olio	3.01.15 - 3.01.17
01	Scatola della distribuzione	3.01.21 - 3.01.22
05	Albero a gomiti	3.05.25 - 3.05.28
05	Corona dentata/Volano	3.05.31
06	Biella	3.06.35 - 3.06.40
07	Pistone	3.07.43 - 3.07.45
08	Testa cilindri	3.08.49 - 3.08.54
10	Albero a camme	3.10.57
11	Supporto del bilanciante	3.11.61
15	Refrigeratore dell'olio	3.15.65 - 3.15.69
17	Pompa del combustibile	3.17.73
19	Iniettore	3.19.77 - 3.19.79
27	Asta a cremagliera	3.27.83 - 3.27.84
33	Compressore dell'aria	3.33.87
38	Termostato	3.38.91
38	Pompa del liquido refrigerante	3.38.95
39	Soffiante di raffreddamento	3.39.99 - 3.39.103
72	Albero dell'equilibratore delle masse	3.72.107
83	Comando della pompa idraulica	3.83.111 - 3.83.113
83	Pompa idraulica con flangia di fissaggio	3.83.117 - 3.83.118

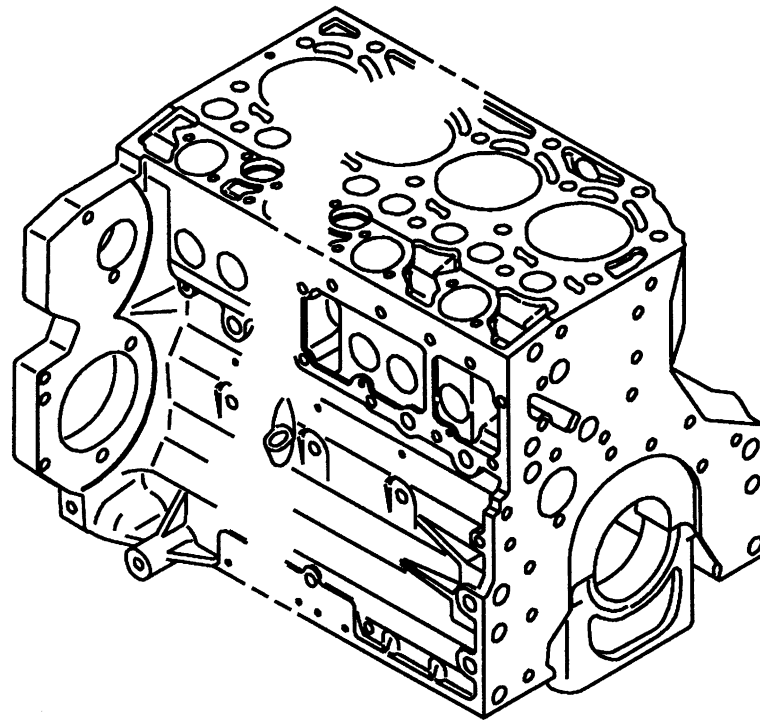

**English**

**Français**

**Italiano**

**Commercial tools required:**

Screw driver socket \_\_\_\_\_ 8112  
 Internal dial gauge

**Special tools required:**

Assembly tool for  
 camshaft sleeves BFM 1012 \_ 143 790  
 BFM 1013 \_ 143 810  
 Assembly tool for  
 engine balancer  
 bushes BFM 1012 \_\_\_\_\_ 143 780  
 Assembly tool for control  
 rod sleeves BFM 1012 \_\_\_\_\_ 110 470  
 BFM 1013 \_\_\_\_\_ 110 480  
 Assembly tool for  
 cylinder liners BFM 1013 \_\_\_\_\_ 150 100  
 Extractor BFM 1013 \_\_\_\_\_ 150 800

1. Clean crankcase and inspect for damage.

**Note:** Prior to measurement tighten main bearing caps as specified.

Initial tightening torque:  
 BFM 1012 **30 Nm**  
 BFM 1013 **50 Nm**  
**1st tightening angle: 60°**  
**2nd tightening angle: 60°**

2. Set internal dial gauge.

BFM 1012 to **94 mm**  
 BFM 1013 to **108 mm**

**Outillage usuel:**

Embout de tournevis \_\_\_\_\_ 8112  
 Appareil de mesure

**Outillage spécial:**

Outil de montage pour bague  
 d'arbre à cames BFM 1012 \_ 143 790  
 BFM 1013 \_ 143 810  
 Outil de montage pour douilles  
 d'arbres à masses d'é  
 quilibrage BFM 1012 \_\_\_\_\_ 143 780  
 Outil de montage pour bague de  
 crémaillère BFM 1012 \_\_\_\_\_ 110 470  
 BFM 1013 \_\_\_\_\_ 110 480  
 Outil de montage pour  
 chemises BFM 1013 \_\_\_\_\_ 150 100  
 Extracteur BFM 1013 \_\_\_\_\_ 150 800

1. Nettoyer le bloc moteur et contrôler visuellement s'il ne présente pas de détérioration.

**Nota:** Avant de procéder au relevé des mesures serrer les chapeaux de paliers de vilebrequin selon les préconisations de serrage.

Valeur de préserrage:  
 BFM 1012 **30 Nm**  
 BFM 1013 **50 Nm**  
 Valeur de serrage à l'angle :  
**1ère passe: 60°**  
**2ème passe: 60°**

2. Régler l'appareil de mesure.

BFM 1012 à **94 mm**  
 BFM 1013 à **108 mm**

**Attrezzi comuni:**

Porta-cacciavite \_\_\_\_\_ 8112  
 Comparatore per interni

**Attrezzi speciali:**

Attrezzo di montaggio per:  
 boccole albero a camme  
 BFM 1012 \_\_\_\_\_ 143 790  
 BFM 1013 \_\_\_\_\_ 143 818  
 Attrezzo di montaggio per:  
 boccole masse controrotanti  
 BFM 1012 \_\_\_\_\_ 143 780  
 Attrezzo di montaggio per:  
 boccole asta cremagliera  
 BFM 1012 \_\_\_\_\_ 110 470  
 BFM 1013 \_\_\_\_\_ 110 480  
 Attrezzo di montaggio per:  
 camicie cilindri BFM 1013 \_\_\_\_\_ 150 100  
 estrattore BFM 1013 \_\_\_\_\_ 150 800

1. Pulire l'incastellatura del motore e controllare che non sia danneggiata.

**Nota:** Prima di eseguire le misurazioni si devono fissare i cappelli dei cuscinetti di banco secondo le prescrizioni di serraggio

Preserraggio:  
 BFM 1012 **30 Nm**  
 BFM 1013 **50 Nm**  
 Serraggio finale:  
**I passaggio 60°**  
**II passaggio 60°**

2. Aggiustaggio del comparatore d'interni

BFM 1012 su **94 mm**  
 BFM 1013 su **108 mm**

**Deutsch**

**Werkstatthandbuch BFM 1012/E, BFM 1013/E**

**Handelsübliche Werkzeuge:**

Schraubendrehereinsatz \_\_\_\_\_ 8112  
 Innenmeßgerät

**Spezialwerkzeuge:**

Montagewerkzeug für  
 Nockenwellenbuchsen BFM 1012 \_\_\_ 143 790  
 BFM 1013 \_\_\_ 143 810  
 Montagewerkzeug für  
 MAG-Buchsen BFM 1012 \_\_\_\_\_ 143 780  
 Montagewerkzeug für  
 Regelstangenbuchsen BFM 1012 \_\_\_ 110 470  
 BFM 1013 \_\_\_ 110 480  
 Montagewerkzeug für  
 Zylinderlaufbuchsen BFM 1013 \_\_\_\_\_ 150 100  
 Ausziehvorrichtung BFM 1013 \_\_\_\_\_ 150 800

1. Kurbelgehäuse reinigen und auf Beschädigung sichtbar prüfen.

**Hinweis:** Vor der Messung sind die Pleuellagerdeckel nach Anziehvorschrift anzuziehen.

Vorspannwert:	BFM 1012	<b>30 Nm</b>
	BFM 1013	<b>50 Nm</b>
Nachspannwert:	<b>1. Stufe</b>	<b>60°</b>
	<b>2. Stufe</b>	<b>60°</b>

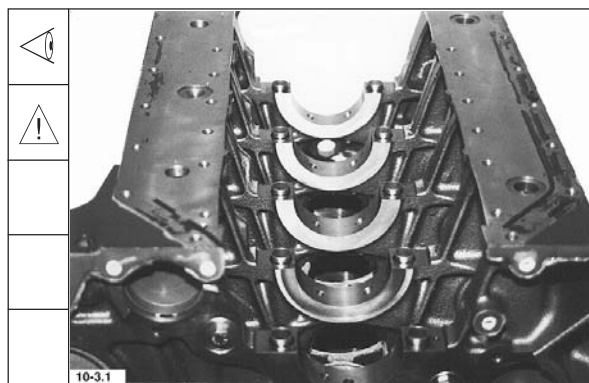

2. Innenmeßgerät einstellen.

BFM 1012 auf	<b>94 mm</b>
BFM 1013 auf	<b>108 mm</b>



Werkstatthandbuch BFM 1012/E, BFM 1013/E

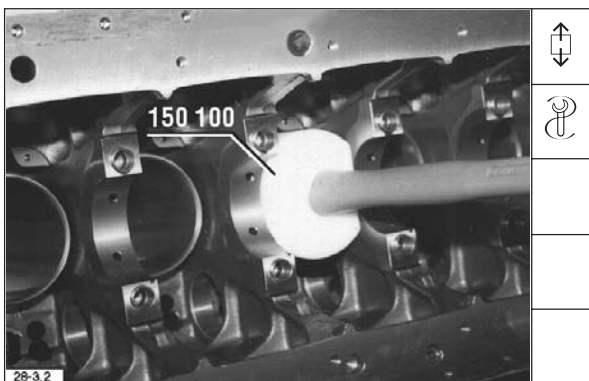
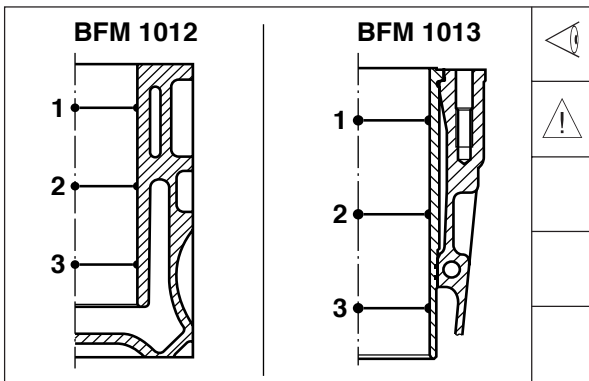
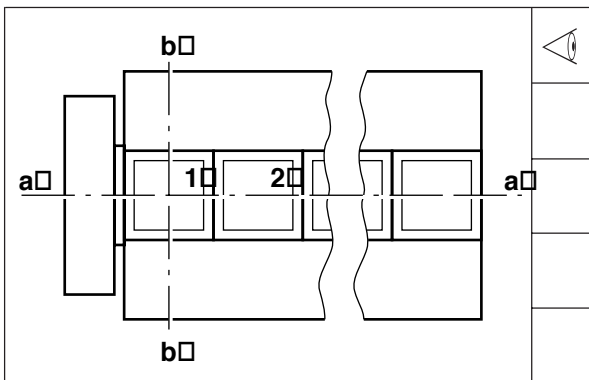
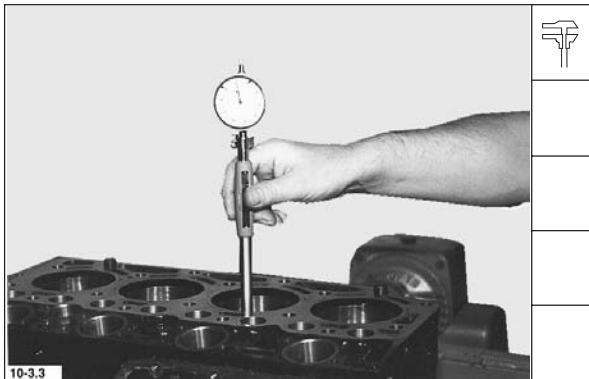

Deutsch

3. Zylinder messen.

Zylinderbohrung: BFM 1012 **94 + 0,02 mm**  
 BFM 1013 **108 + 0,02 mm**

Verschleißgrenze: BFM 1012 **94,1 mm**  
 BFM 1013 **108,1 mm**

3.1 - in der Motorlängsachse "a" und Motorquerachse "b"

3.2 - und in der Ebene 1-3.

**Hinweis:** Zylinderkurbelgehäuse BFM 1012.  
 Bei verschlissener Zylinderlaufbahn besteht die Möglichkeit in unserem Service Center Übersee ein aufgebohrtes, mit neuen Laufbuchsen (Slipfit-Buchsen) ausgerüstetes Zylinderkurbelgehäuse zu beziehen.

4. Zylinderlaufbuchsen ausbauen, bei BFM 1013.



English	Français	Italiano
<p>3. Gauge cylinders-</p> <p>Cylinder bore:            BFM 1012           <b>94 + 0.02 mm</b>            BFM 1013           <b>108 + 0.02 mm</b></p> <p>Wear limit:            BFM 1012           <b>94.1 mm</b>            BFM 1013           <b>108.1 mm</b></p>	<p>3. Mesurer le cylindre-</p> <p>Alésage du cylindre :            BFM 1012           <b>94 + 0,02 mm</b>            BFM 1013           <b>108 + 0,02 mm</b></p> <p>Limite d'usure :            BFM 1012           <b>94,1 mm</b>            BFM 1013           <b>108,1 mm</b></p>	<p>3. Misurazione dei cilindri</p> <p>Alesaggio del cilindro:            BFM 1012           <b>94 + 0,02 mm</b>            BFM 1013           <b>108 + 0,02 mm</b></p> <p>Limite d'usura:            BFM 1012           <b>94,1 mm</b>            BFM 1013           <b>108,1 mm</b></p>
<p>3.1 - in the engine's longitudinal axis „a“ and transverse axis „b“</p>	<p>3.1 dans l'axe dans l'axe longitudinal „a“ et dans l'axe transversal „b“ du moteur.</p>	<p>3.1 - sull'asse trasversale “a” e trasversale “b” del motore</p>
<p>3.2 - and in planes 1-3.</p>	<p>3.2 dans l'axe et sur le plan 1-3.</p>	<p>3.2.- e sul piano 1 - 3</p>
<p><b>Note:</b> BFM 1012 crankcase with integrated cylinder liners. If the cylinder working surface is worn, it is possible to obtain a bored out crankcase equipped with new cylinder liners (slip-fit liners) from our Service Center Übersee.</p>	<p><b>Nota:</b> bloc moteur BFM 1012. Si la surface de frottement du cylindre est usée, il est possible, en s'adressant à notre Service Center Übersee, de se procurer un bloc moteur alésé avec chemises neuves (chemises dites slipfit).</p>	<p><b>Nota:</b> Incastellatura del motore BFM 1012. Se la superficie di lavoro dei cilindri è usurata, esiste la possibilità di ottenere tramite il nostro Service Center Übersee una incastellatura alesata munita di nuove camicie tipo Slipfit.</p>
<p>4. Remove cylinder liners with BFM 1013.</p>	<p>4. Déposer les chemises sur le BFM 1013.</p>	<p>4. Smontaggio delle camicie dei cilindri del motore BFM 1013.</p>



English	Français	Italiano
<p>4.1 With cylinder liners fit for further use inspect liner collar seating and measure at several points on the circumference.            Dimension „X„ = <b>9 - 0.02 mm</b></p> <p><b>Note:</b> Renew cylinder liner in case of damage or dimensional deviation.</p> <p>5. Inspect liner collar seating and sealing surface for cylinder liners.</p> <p>Measure liner collar seating = <b>8.92 + 0.03 mm</b> per cylinder at several points on the circumference.</p> <p><b>Note:</b> Renew crankcase in case of damage or dimensional deviation.</p>	<p>4.1 Si l'on réutilise des chemises, contrôler visuellement la collerette d'appui et procéder en plusieurs emplacements sur la circonférence à un relevé dimensionnel.            Cote „X“ = <b>9 - 0,02 mm</b></p> <p><b>Nota:</b> si la chemise est endommagée ou en cas d'écart de cote, changer la chemise.</p> <p>5. Contrôler visuellement la collerette d'appui et le plan d'appui de la chemise.</p> <p>Sur la circonférence mesurer en plusieurs endroits la cote de la collerette d'appui = <b>8,92 + 0,03 mm</b> pour chaque cylindre.</p> <p><b>Nota:</b> en cas de dommage ou d'écart par rapport à la cote, changer le bloc moteur.</p>	<p>4.1 Se le camicie sono riutilizzabili, controllare il collare e ed eseguirne delle misurazioni in parecchi punti della circonferenza.            Misura "X" = <b>9 - 0,02 mm</b></p> <p><b>Nota:</b> Se la camicia è danneggiata o presenta degli scostamenti dalla misura suddetta deve venire sostituita.</p> <p>5. Controllare sull'incastellatura le sedi del collare delle camicie dei cilindri e le loro superfici di tenuta.</p> <p>Misurare in parecchi punti della circonferenza la sede del collare di ogni cilindro, che deve risultare pari a <b>8,92 - 0,03 mm</b>.</p> <p><b>Nota:</b> Se l'incastellatura è danneggiata o presenta degli scostamenti dalla misura suddetta deve venire sostituita.</p>
<p><b>If the measured data correspond to the values specified for the liners, the crankcase may be repaired as necessary.</b></p>	<p><b>Si le relevé des mesures des cylindres correspond aux valeurs indiquées, au besoin remettre en état le bloc moteur.</b></p>	<p><b>Se le misurazioni effettuate sui cilindri corrispondono ai valori dati, in caso di bisogno l'incastellatura può venire riparata.</b></p>
<p>6. Remove screw plugs. Check oil ducts for free passage.</p>	<p>6. Dévisser et retirer les bouchons filetés. Vérifier le libre passage des canalisations d'huile.</p>	<p>6. Smontare i tappi filettati. Controllare che i condotti dell'olio siano liberi.</p>
<p><b>Camshaft bearing bushes</b></p>	<p><b>Bagues de palier d'arbre à cames</b></p>	<p><b>Gusci dei cuscinetti dell'albero a camme</b></p>
<p>7. Set internal dial gauge:            BFM 1012 to <b>60 mm</b>            BFM 1013 to <b>65 mm</b></p>	<p>7. Régler l'appareil de mesure.            BFM 1012 à <b>60 mm</b>            BFM 1013 à <b>65 mm</b></p>	<p>7. Aggiustare il comparatore per interni            BFM 1012 su <b>60 mm</b>            BFM 1013 su <b>65 mm</b></p>

**Deutsch**

**Werkstatthandbuch BFM 1012/E, BFM 1013/E**

- 4.1 Bei weiterverwendbaren Zylinderlaufbuchsen Bundauflage sichtprüfen und an mehreren Stellen am Umfang messen.  
 Maß „X“ = **9 - 0,02 mm**

**Hinweis:** Bei Beschädigung oder Maßabweichung Zylinderlaufbuchse erneuern.



5. Bundauflage und Dichtfläche für Zylinderlaufbuchse sichtprüfen.  
 Bundauflage = **8,92 + 0,03 mm** je Zylinder an mehreren Stellen am Umfang messen.

**Hinweis:** Bei Beschädigung oder Maßabweichung Kurbelgehäuse erneuern.



**Entsprechen die Messungen der Zylinder den angegebenen Werten, ist nach Bedarf das Zylinderkurbelgehäuse instandzusetzen.**

6. Verschlussschrauben herausrauben. Ölkanaäle auf freien Durchlaß prüfen.

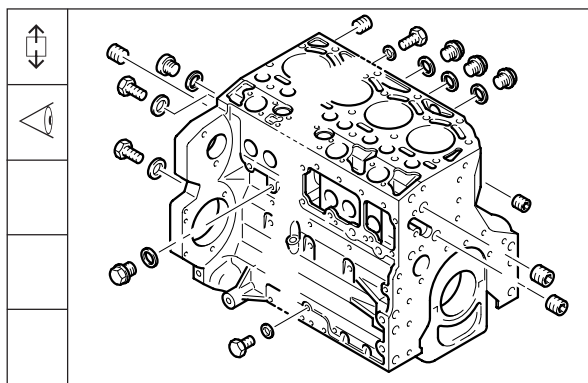

**Nockenwellenlagerbuchsen**

7. Innenmeßgerät einstellen.

BFM 1012 auf **60 mm**  
 BFM 1013 auf **65 mm**

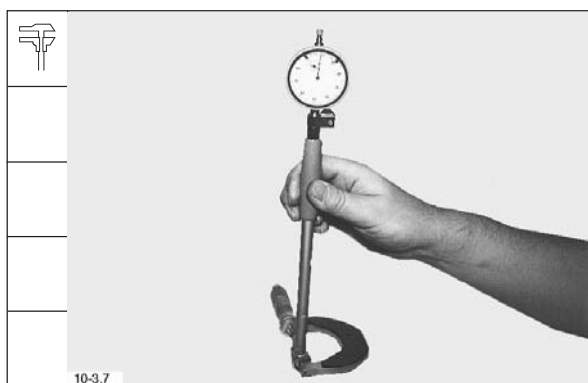

Werkstatthandbuch BFM 1012/E, BFM 1013/E

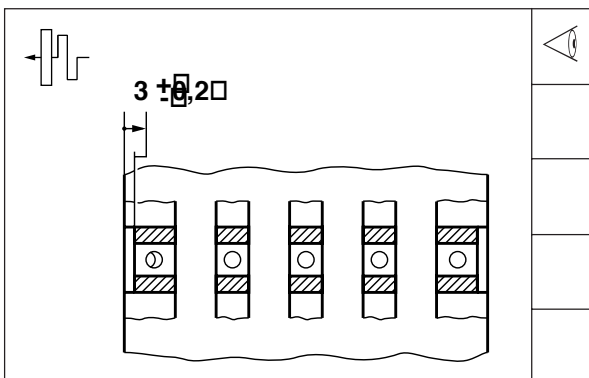
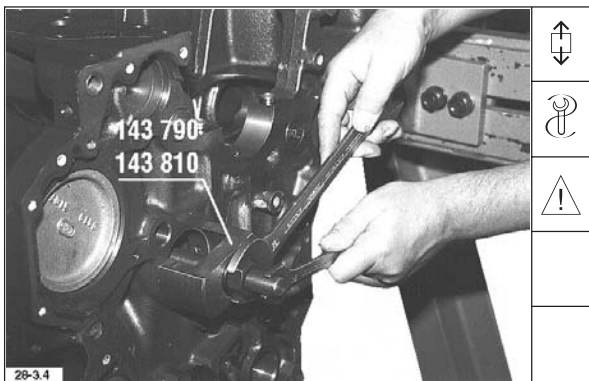
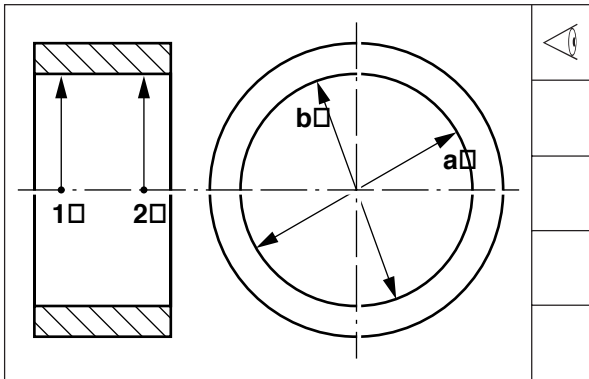

Deutsch

8. Schema zum Vermessen der Lagerbuchsen an den Punkten 1 und 2 in der Ebene "a" und "b".

9. Lagerbuchsen messen, ggf. auswechseln.

Innendurchmesser:  
 BFM 1012 **60 + 0,054 mm**  
 BFM 1013 **65 + 0,054 mm**

Verschleißgrenze:  
 BFM 1012 **60,080 mm**  
 BFM 1013 **65,080 mm**

10. Lagerbuchsen ausbauen.

**Hinweis:** Lagerbuchsen BFM 1013 vor Ausbau markieren und auf neue Lagerbuchsen übertragen.

11. Schema: Einziehmaß der schwungradseitigen Lagerbuchse BFM 1012.

English	Français	Italiano																								
<p>8. Schematic for gauging the bearing bushes at points 1 and 2 in planes „a“ and „b“.</p>	<p>8. Schéma de relevé des mesures des bagues de palier aux points 1 et 2 aux plans „a“ et „b“.</p>	<p>8. Schema per la misurazione dei gusci dei cuscinetti nei punti “1” e “2” dei piani “a” e “b”.</p>																								
<p>9. Gauge bearing bushes, renew if necessary.</p> <p>Inner diameter:</p> <table data-bbox="193 925 571 992"> <tr> <td>BFM 1012</td> <td><b>60 + 0.054 mm</b></td> </tr> <tr> <td>BFM 1013</td> <td><b>65 + 0.054 mm</b></td> </tr> </table> <p>Wear limit:</p> <table data-bbox="193 1055 571 1122"> <tr> <td>BFM 1012</td> <td><b>60.080 mm</b></td> </tr> <tr> <td>BFM 1013</td> <td><b>65.080 mm</b></td> </tr> </table>	BFM 1012	<b>60 + 0.054 mm</b>	BFM 1013	<b>65 + 0.054 mm</b>	BFM 1012	<b>60.080 mm</b>	BFM 1013	<b>65.080 mm</b>	<p>9. Mesurer les bagues de palier, au besoin les changer.</p> <p>Diamètre intérieur:</p> <table data-bbox="639 925 1018 992"> <tr> <td>BFM 1012</td> <td><b>60 + 0,054 mm</b></td> </tr> <tr> <td>BFM 1013</td> <td><b>65 + 0,054 mm</b></td> </tr> </table> <p>Limite d'usure:</p> <table data-bbox="639 1055 1018 1122"> <tr> <td>BFM 1012</td> <td><b>60,080 mm</b></td> </tr> <tr> <td>BFM 1013</td> <td><b>65,080 mm</b></td> </tr> </table>	BFM 1012	<b>60 + 0,054 mm</b>	BFM 1013	<b>65 + 0,054 mm</b>	BFM 1012	<b>60,080 mm</b>	BFM 1013	<b>65,080 mm</b>	<p>9. Misurare i gusci dei cuscinetti e sostituirli, qualora necessario.</p> <p>Diametro interno:</p> <table data-bbox="1082 925 1460 992"> <tr> <td>BFM 1012</td> <td><b>60 + 0,054 mm</b></td> </tr> <tr> <td>BFM 1013</td> <td><b>65 + 0,054 mm</b></td> </tr> </table> <p>Limite di usura:</p> <table data-bbox="1082 1055 1460 1122"> <tr> <td>BFM 1012</td> <td><b>60,080 mm</b></td> </tr> <tr> <td>BFM 1013</td> <td><b>60,080 mm</b></td> </tr> </table>	BFM 1012	<b>60 + 0,054 mm</b>	BFM 1013	<b>65 + 0,054 mm</b>	BFM 1012	<b>60,080 mm</b>	BFM 1013	<b>60,080 mm</b>
BFM 1012	<b>60 + 0.054 mm</b>																									
BFM 1013	<b>65 + 0.054 mm</b>																									
BFM 1012	<b>60.080 mm</b>																									
BFM 1013	<b>65.080 mm</b>																									
BFM 1012	<b>60 + 0,054 mm</b>																									
BFM 1013	<b>65 + 0,054 mm</b>																									
BFM 1012	<b>60,080 mm</b>																									
BFM 1013	<b>65,080 mm</b>																									
BFM 1012	<b>60 + 0,054 mm</b>																									
BFM 1013	<b>65 + 0,054 mm</b>																									
BFM 1012	<b>60,080 mm</b>																									
BFM 1013	<b>60,080 mm</b>																									
<p>10. Remove bearing bushes.</p> <p><b>Note:</b> Mark BFM 1013 bearing bushes prior to removal and adopt marking to new bearing bushes.</p>	<p>10. Déposer les bagues de palier.</p> <p><b>Nota:</b> marquer les douilles de palier du BFM 1013 avant la dépose et porter les repères sur les douilles de palier neuves.</p>	<p>10. Smontaggio dei gusci dei cuscinetti.</p> <p><b>Nota:</b> Prima di smontarli, contrassegnare i gusci dei cuscinetti del motore BFM 1013 ed adottare gli stessi contrasegni per i nuovi gusci.</p>																								
<p>11. Schematic: installation dimension of BFM 1012 bearing bush at flywheel end.</p>	<p>11. Schéma : schéma d'installation d'une bague de palier côté volant pour le BFM 1012.</p>	<p>11. Schema: misura del rientro del guscio del cuscinetto lato volano del BFM1012.</p>																								



English	Français	Italiano
<p>12. Schematic: determining installation position of BFM 1013 bearing bush at flywheel end.</p>	<p>12. Schéma : montage orienté d'une bague de palier côté volant pour le BFM 1013.</p>	<p>12. Schema: misura orientativa per il montaggio del guscio del cuscinetto lato volante del motore MFM 1013.</p>
<p>13. Position new bearing bush.</p> <p><b>Note:</b> Lube oil bores must be lined up.</p>	<p>13. Placer une nouvelle bague de palier.</p> <p><b>Nota:</b> veiller à ce que les trous de graissage correspondent.</p>	<p>13. Posizionare il nuovo guscio.</p> <p><b>Nota:</b> Fare attenzione a far coincidere i fori per il passaggio dell'olio lubrificante.</p>
<p>14. Insert bearing bush.</p>	<p>14. Insérer la bague de palier.</p>	<p>14. Far entrare il guscio del cuscinetto.</p>
<p><b>Engine balancer - BFM 1012 bearing bushes</b></p> <p>15. Set internal dial gauge to <b>54 mm</b>.</p>	<p><b>Masses d'équilibrage (MAG) - bagues de palier BFM 1012</b></p> <p>15. Régler l'appareil de mesure sur une valeur de <b>54 mm</b>.</p>	<p><b>Gusci dei cuscinetti delle masse controrotanti del BFM 1012.</b></p> <p>15. Aggiustare su <b>54 mm</b> il comparatore per interni.</p>

Deutsch

Werkstatthandbuch BFM 1012/E, BFM 1013/E

12. Schema: Orientierter Einbau der schwungradseitigen Lagerbuchse BFM 1013.

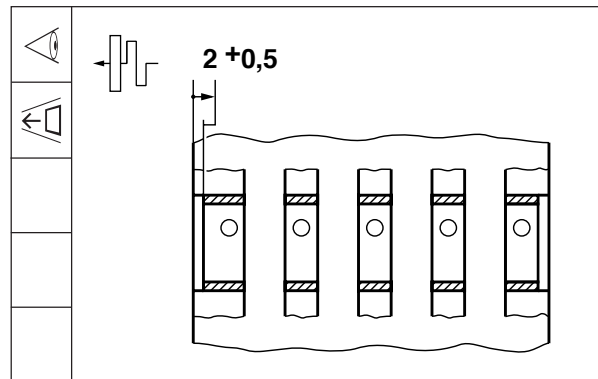

13. Neue Lagerbuchse ansetzen.

**Hinweis:** Auf Übereinstimmung der Schmierölbohrungen achten.

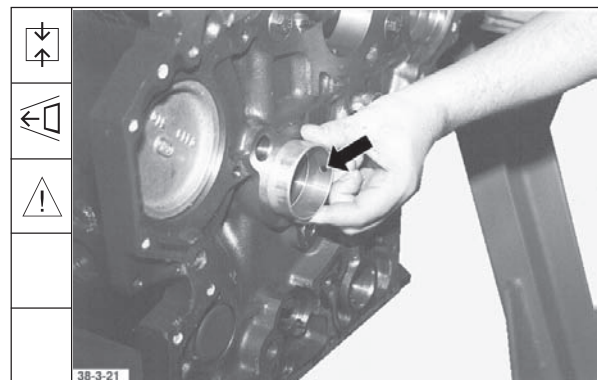

14. Lagerbuchse einziehen.

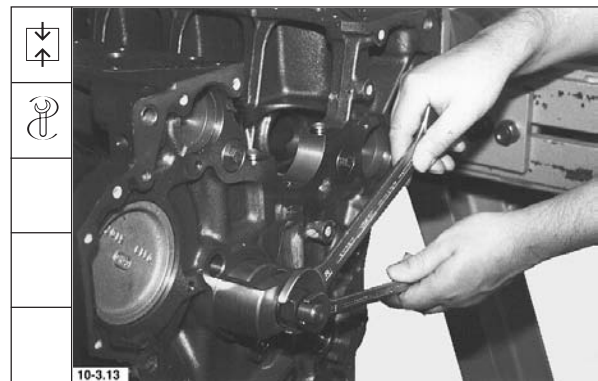

**Massenausgleich (MAG) - Lagerbuchsen  
BFM 1012**

15. Innenmeßgerät auf 54 mm einstellen.



Werkstatthandbuch BFM 1012/E, BFM 1013/E

Deutsch

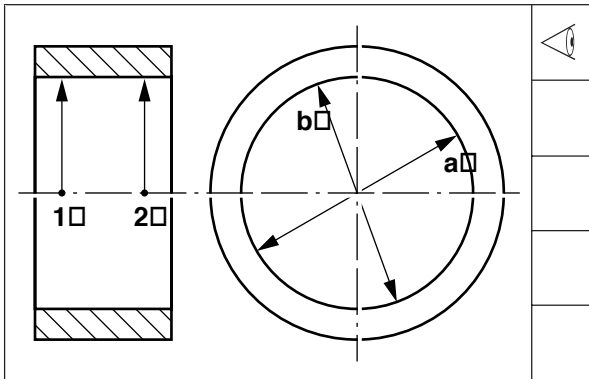

16. Schema zum Vermessen der Lagerbuchsen an den Punkten 1 und 2 in der Ebene "a" und "b".

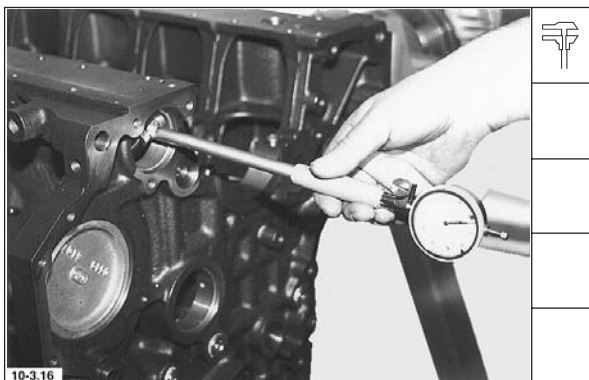

17. Lagerbuchsen messen, ggf. auswechseln.

Innendurchmesser: **54,06 + 0,045 mm**  
 Verschleißgrenze: **54,125 mm**

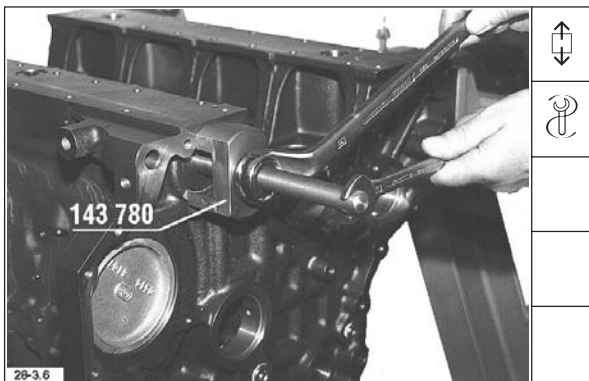

18. Lagerbuchsen ausbauen.

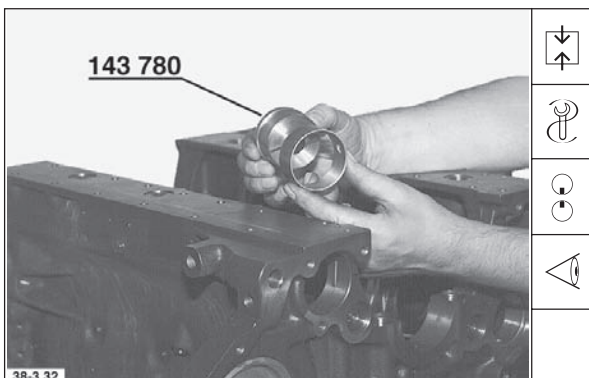

19. Neue Lagerbuchse ansetzen, markieren und auf Übereinstimmung der Schmierölbohrungen / Zentrierbohrungen achten.



English	Français	Italiano
<p>16. Schematic for gauging the bearing bushes at points 1 and 2 and in planes „a“ and „b“.</p>	<p>16. Schéma de relevé des mesures aux points 1 et 2 aux plans „a“ et „b“.</p>	<p>16. Schema per la misurazione dei gusci dei cuscinetti nei punti “1” e “2” dei piani “a” e “b”.</p>
<p>17. Gauge bearing bushes, renew if necessary.</p> <p>Inner diameter: <b>54.06 + 0.045 mm</b>  Wear limit: <b>54.125 mm</b></p>	<p>17. Mesurer les bagues de palier, au besoin les changer.</p> <p>Diamètre intérieur: <b>54,06 + 0,045 mm</b>  Usure limite: <b>54,125 mm</b></p>	<p>17. Misurare i gusci dei cuscinetti e sostituirli, qualora necessario.</p> <p>Diametro interno: <b>54,06 + 0,045 mm</b>  Limite di usura: <b>54,125 mm</b></p>
<p>18. Remove bearing bushes.</p>	<p>18. Déposer les bagues de palier.</p>	<p>18. Smontaggio dei gusci dei cuscinetti.</p>
<p>19. Position new bearing bush, mark and make sure that lube oil bores/centering bores are lined up.</p>	<p>19. Placer une bague de palier neuve, repérer et veiller à ce que les trous de graissage et les trous de centrage correspondent.</p>	<p>19. Posizionare il nuovo guscio del cuscinetto, contrassegnarlo ed assicurarsi che coincidano sia i fori di passaggio dell’olio lubrificante che quelli di centraggio.</p>

English	Français	Italiano
20. Insert bearing bush.	20. Introduire la bague de palier.	20. Far entrare il guscio del cuscinetto.
<b>Guide sleeves for control rod</b>	<b>Bagues de guidage pour crémaillère</b>	<b>Bussole di guida per l'asta a cremagliera</b>
21. With BF4/6M engines drive out guide sleeve at front end.	21. Sur les moteurs BF4/6M chasser la goupille cylindrique vers l'avant.	21. Sui motori BF4/6M spingere fuori la bussola di guida anteriore.
22. With BF6M engines drive out guide sleeve at flywheel end.	22. Sur le BF6M retirer la douille de guidage côté volant moteur.	22. Sul motore BF6M spingere fuori la bussola di guida sul lato volano.
23. Introduce short assembly arbor in centering bore.	23. Insérer le mandrin de montage court dans le trou de centrage.	23. Introdurre nel foro di centraggio un corto spinotto di montaggio.

Deutsch

Werkstatthandbuch BFM 1012/E, BFM 1013/E

20. Lagerbuchse einziehen.

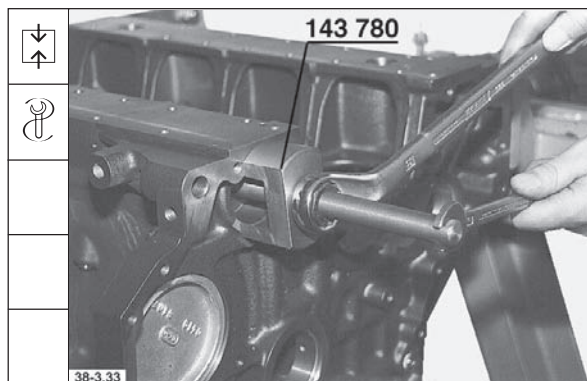

Führungsbuchsen für Regelstange

21. Führungsbuchse vorne austreiben, bei BF4/6M Motoren.

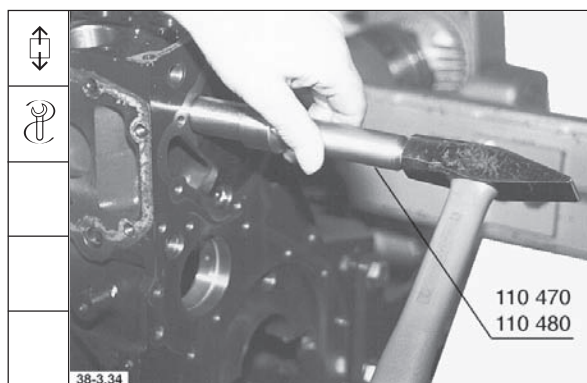

22. Führungsbuchse schwungradseitig austreiben, bei BF6M Motor.

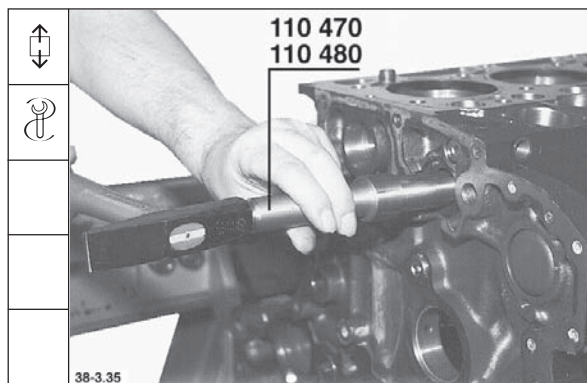

23. Kurzen Montagedorn in Zentrierung schieben.

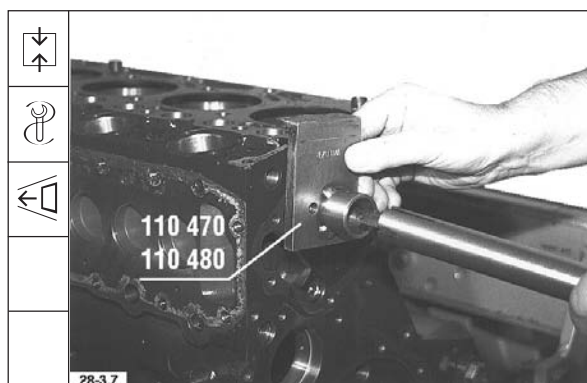

Werkstatthandbuch BFM 1012/E, BFM 1013/E

Deutsch

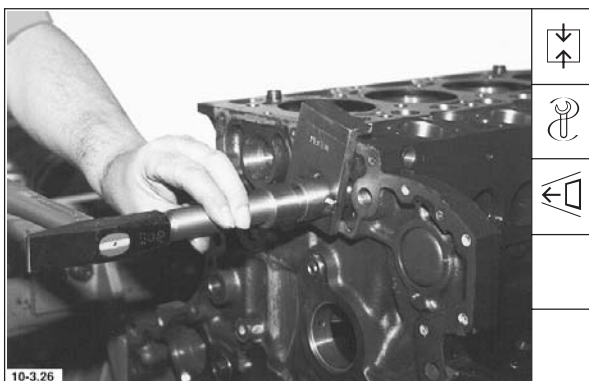
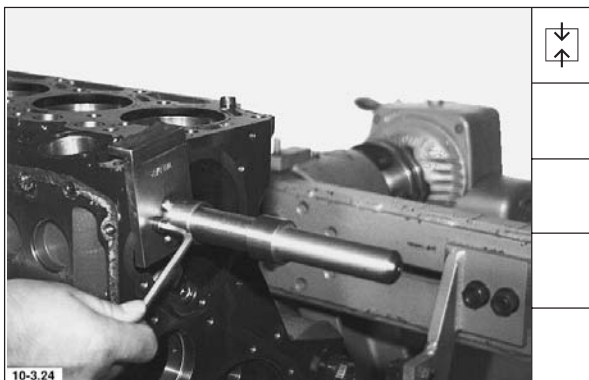
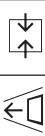
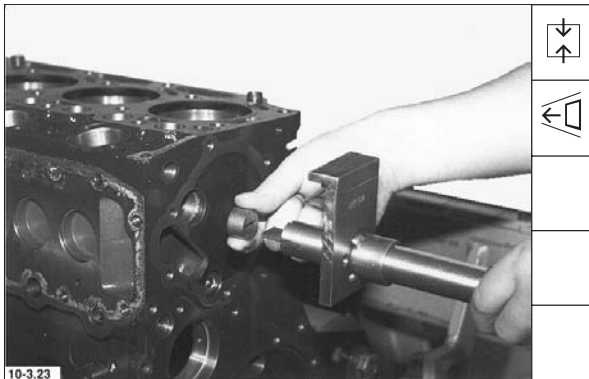

24. Führungsbuchse auf den Montagedorn, mit der Anfasung zum Kurbelgehäuse weisend, aufsetzen.

25. Zentrierung mit Montagedorn am Kurbelgehäuse festdrehen.

26. Führungsbuchse bis Anschlag eintreiben.

27. Bei BF6M Motor Führungsbuchse schwungradseitig wie Pos. 23-26, jedoch mit langem Montagedorn, eintreiben.

English	Français	Italiano
24. Position guide sleeve on assembly arbor with chamfer pointing towards crankcase.	24. Placer la bague de guidage sur le mandrin de montage en dirigeant le chanfrein vers le bloc moteur.	24. Infilare la bussola di guida sullo spinotto di montaggio, avendo cura che lo smusso sia rivolto verso l'incastellatura.
25. Secure centering bore with assembly arbor on crankcase.	25. Bloquer le centrage sur le bloc moteur avec le mandrin de montage.	25. Fissare sull'incastellatura illo spinotto di montaggio assieme al dispositivo di centraggio. di centraggio
26. Drive in guide sleeve as far as it will go.	26. Insérer la bague de guidage jusqu'en position de butée.	26. Far ulteriormente entrare la bussola di guida fino alla posizione di battuta.
27. With BF6M engines drive in guide sleeve at flywheel end as under items 23-26, using however long assembly arbor.	27. Sur le BF6M introduire la bague de guidage côté volant moteur comme au pt. 23-26 en utilisant le mandrin de montage long.	27. Col motore BF6M far entrare la bussola di guida dal lato volano come nelle posizioni 23 - 26, però per mezzo di uno spinotto di montaggio più lungo.

English	Français	Italiano
<p><b>Pressure holding valve BFM 1013</b> (remove if necessary)</p> <p>28. Bore out bore in pressure holding valve with drill, 6.7 mm dia.</p> <p>29. Tap thread M8.</p> <p>30. Screw in extractor and drive out pressure holding valve.</p> <p>31. Apply locking compound <b>Deutz DW 71</b> to new pressure holding valve.</p>	<p><b>Clapet de retenue BFM 1013</b> (le déposer si nécessaire)</p> <p>28. Elargir l'alésage du clapet de retenue à l'aide d'un foret diam. 6,7 mm.</p> <p>29. Tailler filetage M8.</p> <p>30. Introduire et visser extracteur puis retirer le clapet de retenue.</p> <p>31. Enduire le clapet de retenue de pâte d'étanchéité <b>Deutz DW 71</b>.</p>	<p><b>Valvola di ritegno della pressione BFM 1013</b> (smontarla qualora necessario)</p> <p>28. Per mezzo di una punta Ø 6,7 mm allargare il foro della valvola di mantenimento della pressione.</p> <p>29. Eseguire una filettatura M8.</p> <p>30. Avvitarvi l'estrattore ed estrarre la valvola di mantenimento della pressione.</p> <p>31. Spalmare con ermetico <b>Deutz DW 71</b> la nuova valvola di mantenimento della pressione.</p>

Deutsch

Werkstatthandbuch BFM 1012/E, BFM 1013/E

**Druckhalteventil BFM 1013**  
(falls erforderlich ausbauen)

28. Bohrung im Druckhalteventil mit Bohrer  $\varnothing$  6,7 mm aufbohren.

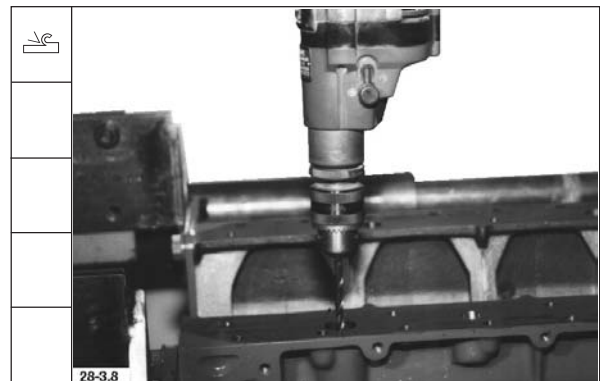

29. Gewinde M 8 schneiden.

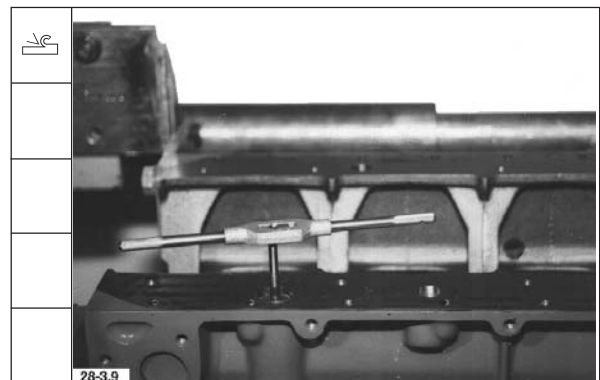

30. Ausziehvorrichtung einschrauben und Druckhalteventil herausziehen.

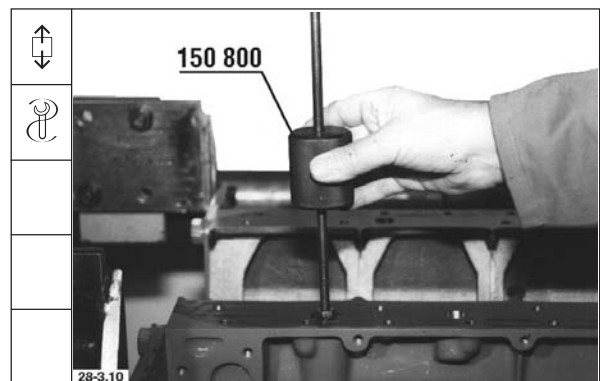

31. Neues Druckhalteventil mit Sicherungsmittel **Deutz DW 71** bestreichen.

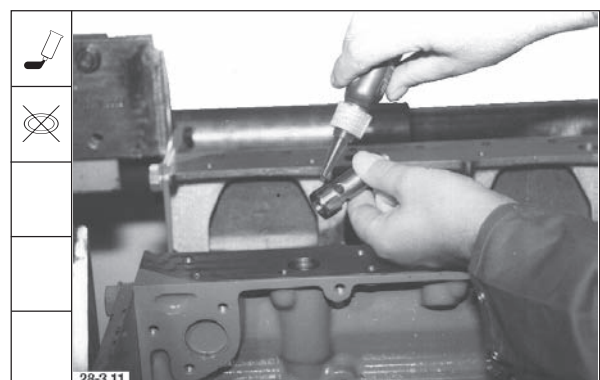

Werkstatthandbuch BFM 1012/E, BFM 1013/E

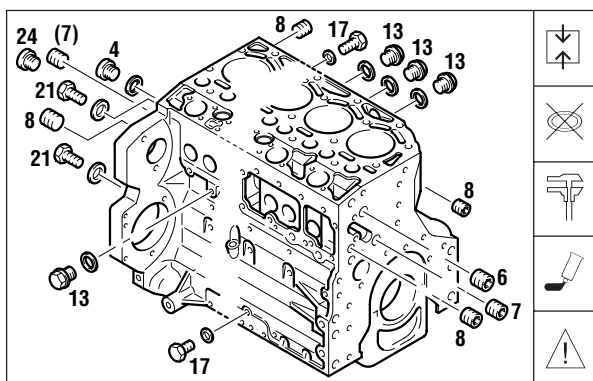
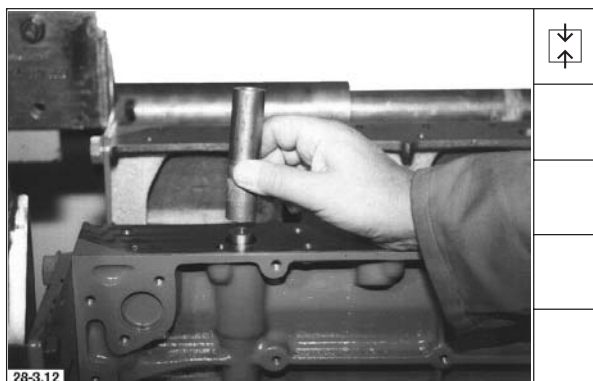

Deutsch

32. Druckhalteventil mit selbstgefertigtem Werkzeug eintreiben.

33. Verschlussschrauben nach Anziehvorschrift festdrehen. Pos. 4,13,17 und 21 mit neuen Cu-Ringen.  
 Pos. 24 mit Sicherungsmittel **DEUTZ DW 72** einsetzen.

	BFM 1012	BFM 1013
Pos. 4 =	<b>35 ± 3,5 Nm</b>	
Pos. 6 =	<b>95 ± 9,5 Nm</b>	
Pos. 7 =	<b>65 ± 6,5 Nm</b>	
Pos. 8 =	<b>35 ± 3,5 Nm</b>	
Pos. 13 =	<b>35 ± 3,5 Nm</b>	
Pos. 17 =	<b>29 Nm</b>	—
Pos. 21 =	<b>9 + 4 Nm</b>	—
Pos. 24 =	—	<b>10 ± 2,0 Nm</b>

**Hinweis:** Nach Demontage der Pos. 6,7 und 8 sind diese grundsätzlich zu erneuern.  
 In ( ) gesetzte Pos.7 wurde durch Pos. 24 abgelöst.

Zylinderlaufbuchsen BFM 1013

34. Auf absolute Sauberkeit der Bundauflage und Dichtfläche achten.





English	Français	Italiano																																																
<p>32. Drive in pressure holding valve with self-made tool.</p>	<p>32. Insérer le clapet de retenue à l'aide d'un outil de fabrication locale.</p>	<p>32. Far entrare la valvola di mantenimento della pressione aiutandosi con un attrezzo autocostruito.</p>																																																
<p>33. Tighten screw plugs as specified. Use new Cu seals for items 4, 13, 17 and 21. Insert item 24 with locking compound <b>Deutz DW 72</b>.</p>	<p>33. Bloquer les vis filetées selon les préconisations de serrage. Rep.4, 13, 17 et 21 avec des bagues Cu neuves. Placer rep.24 avec de la pâte d'étanchéité <b>DEUTZ DW 72</b>.</p>	<p>33. Rimontare i tappi filettati, bloccandoli in base alle prescrizioni di serraggio. Per le pos. 4, 13, 17 e 21 utilizzare nuovi anelli di rame. Per la pos. 24 impiegare l'ermetico <b>Deutz DW 72</b>.</p>																																																
<table border="0"> <tr> <td style="padding-right: 10px;">BFM 1012</td> <td style="border-left: 1px solid black; padding-left: 10px;">BFM 1013</td> </tr> </table>	BFM 1012	BFM 1013	<table border="0"> <tr> <td style="padding-right: 10px;">BFM 1012</td> <td style="border-left: 1px solid black; padding-left: 10px;">BFM 1013</td> </tr> </table>	BFM 1012	BFM 1013	<table border="0"> <tr> <td style="padding-right: 10px;">BFM 1012</td> <td style="border-left: 1px solid black; padding-left: 10px;">BFM 1013</td> </tr> </table>	BFM 1012	BFM 1013																																										
BFM 1012	BFM 1013																																																	
BFM 1012	BFM 1013																																																	
BFM 1012	BFM 1013																																																	
<table border="0"> <tr> <td style="padding-right: 10px;">item 4 =</td> <td style="border-left: 1px solid black; padding-left: 10px;"><b>35 ± 3.5 Nm</b></td> </tr> <tr> <td style="padding-right: 10px;">item 6 =</td> <td style="border-left: 1px solid black; padding-left: 10px;"><b>95 ± 9.5 Nm</b></td> </tr> <tr> <td style="padding-right: 10px;">item 7 =</td> <td style="border-left: 1px solid black; padding-left: 10px;"><b>65 ± 6.5 Nm</b></td> </tr> <tr> <td style="padding-right: 10px;">item 8 =</td> <td style="border-left: 1px solid black; padding-left: 10px;"><b>35 ± 3.5 Nm</b></td> </tr> <tr> <td style="padding-right: 10px;">item 13 =</td> <td style="border-left: 1px solid black; padding-left: 10px;"><b>35 ± 3.5 Nm</b></td> </tr> <tr> <td style="padding-right: 10px;">item 17 =</td> <td style="border-left: 1px solid black; padding-left: 10px;"><b>29 Nm</b>   —</td> </tr> <tr> <td style="padding-right: 10px;">item 21 =</td> <td style="border-left: 1px solid black; padding-left: 10px;"><b>9 + 4 Nm</b>   —</td> </tr> <tr> <td style="padding-right: 10px;">item 24 =</td> <td style="border-left: 1px solid black; padding-left: 10px;">—   <b>10 ± 2.0 Nm</b></td> </tr> </table>	item 4 =	<b>35 ± 3.5 Nm</b>	item 6 =	<b>95 ± 9.5 Nm</b>	item 7 =	<b>65 ± 6.5 Nm</b>	item 8 =	<b>35 ± 3.5 Nm</b>	item 13 =	<b>35 ± 3.5 Nm</b>	item 17 =	<b>29 Nm</b>   —	item 21 =	<b>9 + 4 Nm</b>   —	item 24 =	—   <b>10 ± 2.0 Nm</b>	<table border="0"> <tr> <td style="padding-right: 10px;">Rep. 4 =</td> <td style="border-left: 1px solid black; padding-left: 10px;"><b>35 ± 3.5 Nm</b></td> </tr> <tr> <td style="padding-right: 10px;">Rep. 6 =</td> <td style="border-left: 1px solid black; padding-left: 10px;"><b>95 ± 9.5 Nm</b></td> </tr> <tr> <td style="padding-right: 10px;">Rep. 7 =</td> <td style="border-left: 1px solid black; padding-left: 10px;"><b>65 ± 6.5 Nm</b></td> </tr> <tr> <td style="padding-right: 10px;">Rep. 8 =</td> <td style="border-left: 1px solid black; padding-left: 10px;"><b>35 ± 3,5 Nm</b></td> </tr> <tr> <td style="padding-right: 10px;">Rep. 13 =</td> <td style="border-left: 1px solid black; padding-left: 10px;"><b>35 ± 3,5 Nm</b></td> </tr> <tr> <td style="padding-right: 10px;">Rep. 17 =</td> <td style="border-left: 1px solid black; padding-left: 10px;"><b>29 Nm</b>   —</td> </tr> <tr> <td style="padding-right: 10px;">Rep. 21 =</td> <td style="border-left: 1px solid black; padding-left: 10px;"><b>9 + 4 Nm</b>   —</td> </tr> <tr> <td style="padding-right: 10px;">Rep. 24 =</td> <td style="border-left: 1px solid black; padding-left: 10px;">—   <b>10 ± 2,0 Nm</b></td> </tr> </table>	Rep. 4 =	<b>35 ± 3.5 Nm</b>	Rep. 6 =	<b>95 ± 9.5 Nm</b>	Rep. 7 =	<b>65 ± 6.5 Nm</b>	Rep. 8 =	<b>35 ± 3,5 Nm</b>	Rep. 13 =	<b>35 ± 3,5 Nm</b>	Rep. 17 =	<b>29 Nm</b>   —	Rep. 21 =	<b>9 + 4 Nm</b>   —	Rep. 24 =	—   <b>10 ± 2,0 Nm</b>	<table border="0"> <tr> <td style="padding-right: 10px;">Pos. 4 =</td> <td style="border-left: 1px solid black; padding-left: 10px;"><b>35 ± 3.5 Nm</b></td> </tr> <tr> <td style="padding-right: 10px;">Pos. 6 =</td> <td style="border-left: 1px solid black; padding-left: 10px;"><b>95 ± 9.5 Nm</b></td> </tr> <tr> <td style="padding-right: 10px;">Pos. 7 =</td> <td style="border-left: 1px solid black; padding-left: 10px;"><b>65 ± 6.5 Nm</b></td> </tr> <tr> <td style="padding-right: 10px;">Pos. 8 =</td> <td style="border-left: 1px solid black; padding-left: 10px;"><b>35 ± 3,5 Nm</b></td> </tr> <tr> <td style="padding-right: 10px;">Pos. 13 =</td> <td style="border-left: 1px solid black; padding-left: 10px;"><b>35 ± 3,5 Nm</b></td> </tr> <tr> <td style="padding-right: 10px;">Pos. 17 =</td> <td style="border-left: 1px solid black; padding-left: 10px;"><b>29 Nm</b>   —</td> </tr> <tr> <td style="padding-right: 10px;">Pos. 21 =</td> <td style="border-left: 1px solid black; padding-left: 10px;"><b>9 + 4 Nm</b>   —</td> </tr> <tr> <td style="padding-right: 10px;">Pos. 24 =</td> <td style="border-left: 1px solid black; padding-left: 10px;">—   <b>10 ± 2,0 Nm</b></td> </tr> </table>	Pos. 4 =	<b>35 ± 3.5 Nm</b>	Pos. 6 =	<b>95 ± 9.5 Nm</b>	Pos. 7 =	<b>65 ± 6.5 Nm</b>	Pos. 8 =	<b>35 ± 3,5 Nm</b>	Pos. 13 =	<b>35 ± 3,5 Nm</b>	Pos. 17 =	<b>29 Nm</b>   —	Pos. 21 =	<b>9 + 4 Nm</b>   —	Pos. 24 =	—   <b>10 ± 2,0 Nm</b>
item 4 =	<b>35 ± 3.5 Nm</b>																																																	
item 6 =	<b>95 ± 9.5 Nm</b>																																																	
item 7 =	<b>65 ± 6.5 Nm</b>																																																	
item 8 =	<b>35 ± 3.5 Nm</b>																																																	
item 13 =	<b>35 ± 3.5 Nm</b>																																																	
item 17 =	<b>29 Nm</b>   —																																																	
item 21 =	<b>9 + 4 Nm</b>   —																																																	
item 24 =	—   <b>10 ± 2.0 Nm</b>																																																	
Rep. 4 =	<b>35 ± 3.5 Nm</b>																																																	
Rep. 6 =	<b>95 ± 9.5 Nm</b>																																																	
Rep. 7 =	<b>65 ± 6.5 Nm</b>																																																	
Rep. 8 =	<b>35 ± 3,5 Nm</b>																																																	
Rep. 13 =	<b>35 ± 3,5 Nm</b>																																																	
Rep. 17 =	<b>29 Nm</b>   —																																																	
Rep. 21 =	<b>9 + 4 Nm</b>   —																																																	
Rep. 24 =	—   <b>10 ± 2,0 Nm</b>																																																	
Pos. 4 =	<b>35 ± 3.5 Nm</b>																																																	
Pos. 6 =	<b>95 ± 9.5 Nm</b>																																																	
Pos. 7 =	<b>65 ± 6.5 Nm</b>																																																	
Pos. 8 =	<b>35 ± 3,5 Nm</b>																																																	
Pos. 13 =	<b>35 ± 3,5 Nm</b>																																																	
Pos. 17 =	<b>29 Nm</b>   —																																																	
Pos. 21 =	<b>9 + 4 Nm</b>   —																																																	
Pos. 24 =	—   <b>10 ± 2,0 Nm</b>																																																	
<p><b>Note:</b> Always renew items 6,7 and 8 after removal. Item 7 in brackets ( ) has been superseded by item 24.</p>	<p><b>Nota:</b> après démontage des rep. 6, 7 et 8 toujours remplacer ces pièces par des neuves. Le repère 7 entre parenthèses a été remplacé par le repère 24.</p>	<p><b>Nota:</b> Dopo che sono state smontate, le pos. 6, 7 ed 8 devono sempre venire sostituite. La pos. 7 tra parentesi è stata sostituita con la pos. 24.</p>																																																
<p><b>Cylinder liners BFM 1013</b></p>	<p><b>Chemises BFM 1013</b></p>	<p><b>Camicie dei cilindri BFM 1013</b></p>																																																
<p>34. Make sure that collar seating and sealing surface are absolutely clean.</p>	<p>34. Veiller à ce que la collerette et le plan d'appui soient parfaitement propres.</p>	<p>34. Le sedi dei collari e le superfici di appoggio devono essere perfettamente pulite.</p>																																																



English	Français	Italiano
<p>35. Fit O-seals.</p> <p><b>Note:</b> Prior to assembly oil crankcase and cylinder liner in the area X.</p>	<p>35. Monter les joints toriques.</p> <p><b>Nota:</b> après montage huiler bloc moteur et chemise dans la partie X.</p>	<p>35. Montare gli O-ring.</p> <p><b>Nota:</b> Prima di montarli oliare l'incastellatura e le camicie dei cilindri nella zona X.</p>
<p>36. Press in cylinder liner as far as it will go.</p>	<p>36. Introduire la chemise jusqu'en position d'appui.</p>	<p>36. Infilare le camicie dei cilindri e spingerle fino alla battuta.</p>

Deutsch

Werkstatthandbuch BFM 1012/E, BFM 1013/E

35. Runddichtringe aufziehen.

**Hinweis:** Vor Montage Kurbelgehäuse und Zylinderlaufbuchse im Bereich X einölen.

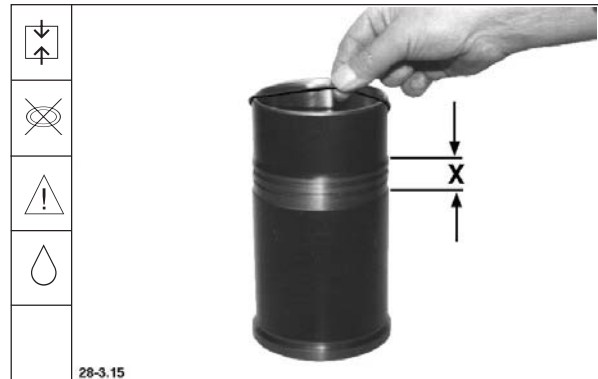

36. Zylinderlaufbuchse bis Anlage eindrücken.

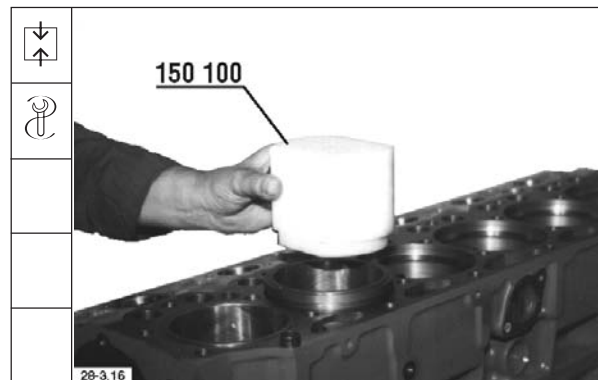

**Bauteile instand setzen**  
**Repair of components**  
**Mise en état des composants**  
**Riparazione dei componenti**

---

**Vorderer Deckel/ Schmierölpumpe**  
**Front cover/ Lube oil pump**  
**Couvercle avant/ Pompe à huile de graissage**  
**Coperchio anteriore/Coppa dell'olio**

**Bauteile instandsetzen**  
**Repair of components**  
**Mise en état des composants**  
**Riparazione dei componenti**

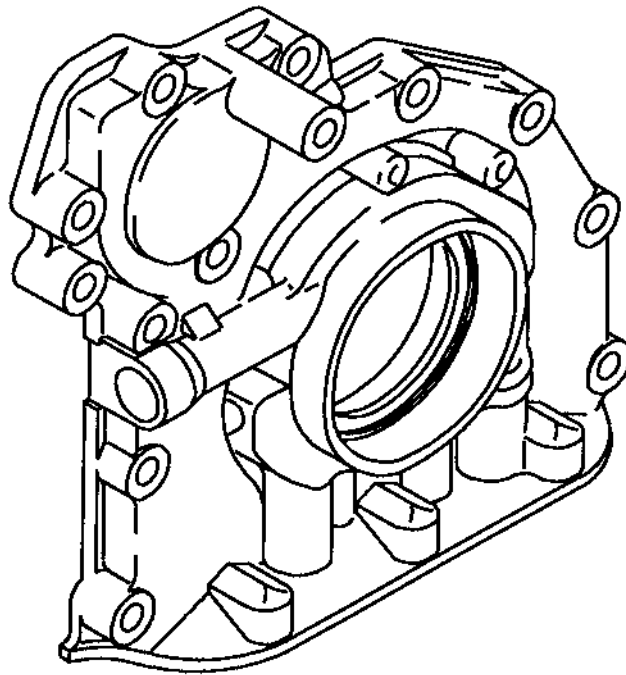

English	Français	Italiano
<p><b>Commercial tool required:</b> Use valve spring assembly lever for pressure control valve on BFM1013.</p> <p><b>Special tools required:</b> Assembly tool BFM 1012 ____ 142 900 BFM 1013 _____ 142 920</p> <p>Assembly tool for pressure control valve BFM 1013 _____ 150 110</p>	<p><b>Outillage usuel:</b> Pour le BFM 1013 utiliser le levier de montage à ressort pour soupape de pression.</p> <p><b>Outillage spécial :</b> Dispositif de montage BFM 1012 _____ 142 900 BFM 1013 _____ 142 920 Outil de montage pour soupape de régulation de pression BFM 1013 _____ 150 110</p>	<p><b>Attrezzi comuni:</b> Per la valvola di mandata dei motori BFM 1013 utilizzare la leva di montaggio delle molle delle valvole.</p> <p><b>Attrezzi speciali:</b> Dispositivo di montaggio: BFM 1012 _____ 142 900 BFM 1013 _____ 142 920 Attrezzo di montaggio della valvola di regolazione della pressione per: BFM 1013 _____ 150 110</p>
<p>1. Drive out shaft seal.</p>	<p>1. Chasser le joint d'arbre.</p>	<p>1. Estrarre l'anello paraolio.</p>
<p>2. Inspect front cover, replace if necessary.</p>	<p>2. Contrôler visuellement le couvercle avant, au besoin le remplacer.</p>	<p>2. Eseguire un controllo visivo del coperchio anteriore e sostituirlo qualora necessario.</p>
<p><b>Note:</b> Rotors must turn freely.</p>	<p><b>Nota:</b> les rotors doivent tourner librement.</p>	<p><b>Nota:</b> gli elementi rotanti della pompa devono poter girare liberamente</p>
<p>3. For cleaning front cover remove lube oil pump and pressure control valve.</p> <p>Unscrew pressure control valve on BFM 1012.</p>	<p>3. Pour nettoyer le couvercle avant déposer la pompe à huile et la soupape de régulation de pression.</p> <p>Dévisser et extraire la soupape de régulation de pression du BFM 1012.</p>	<p>3. Per poter pulire il coperchio anteriore si deve smontare la pompa dell'olio e la valvola di regolazione della pressione.</p> <p>Nel motore BFM 1012 svitare e smontare la valvola di regolazione della pressione.</p>

Deutsch

Werkstatthandbuch BFM 1012/E, BFM 1013/E

**Handelsübliches Werkzeug:**

Bei BFM 1013 Ventildfedermontagehebel für  
Druckventil verwenden

**Spezialwerkzeuge:**

Montagevorrichtung BFM 1012 \_\_\_\_\_ 142 900  
BFM 1013 \_\_\_\_\_ 142 920

Montagewerkzeug für  
Druckregelventil BFM 1013 \_\_\_\_\_ 150 110

1. Wellendichtring austreiben.

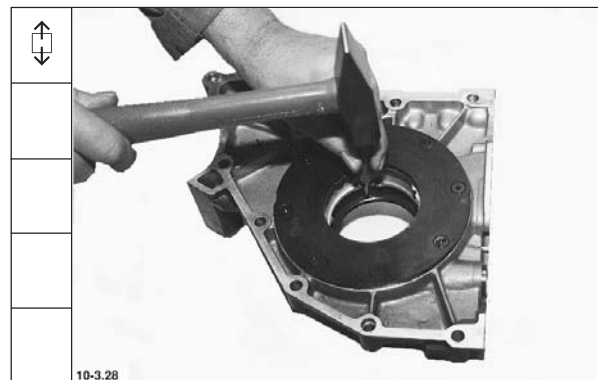

2. Vorderen Deckel sichtprüfen, ggf. austauschen.

**Hinweis:** Rotoren müssen leichtgängig  
drehbar sein.

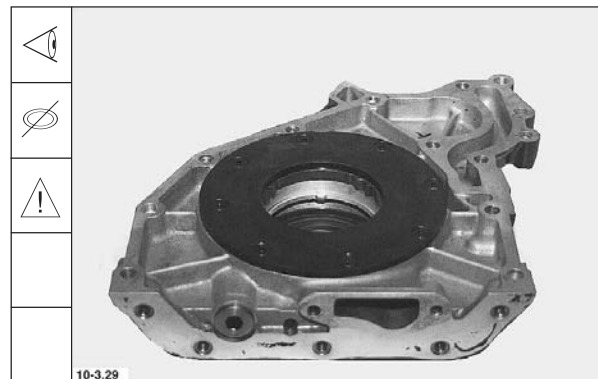

3. Zum Reinigen des vorderen Deckels  
Schmierölpumpe und Druckregelventil  
ausbauen.

Druckregelventil BFM 1012 herauschrau-  
ben.

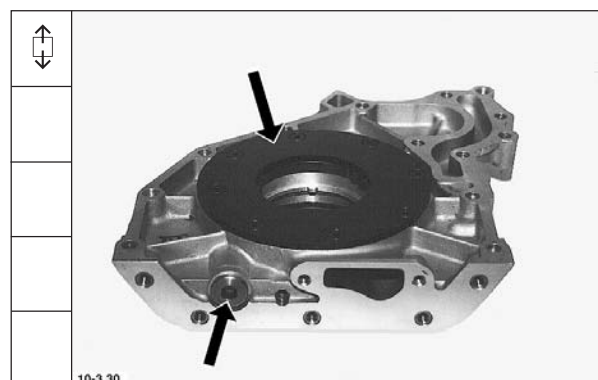

Werkstatthandbuch BFM 1012/E, BFM 1013/E

Deutsch

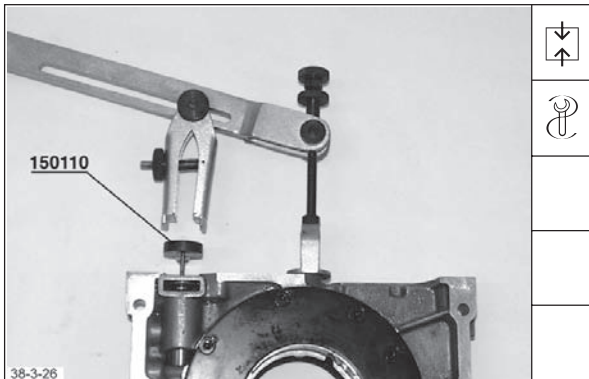

- 3.1 Druckregelventil BFM 1013:  
 Montagewerkzeug auf Druckfeder aufsetzen.  
 Ventildruckspannvorrichtung anbauen.

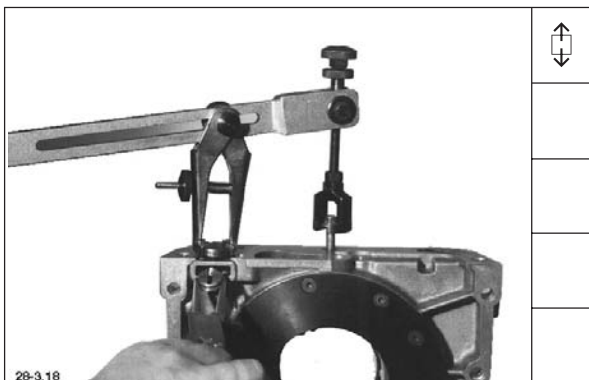

- 3.2 Druckfeder hinunterdrücken und Haltescheibe herausnehmen.



4. Bei sichtbarem Verschleiß oder Beschädigung an den Einzelteilen ist der komplette vordere Deckel auszutauschen.

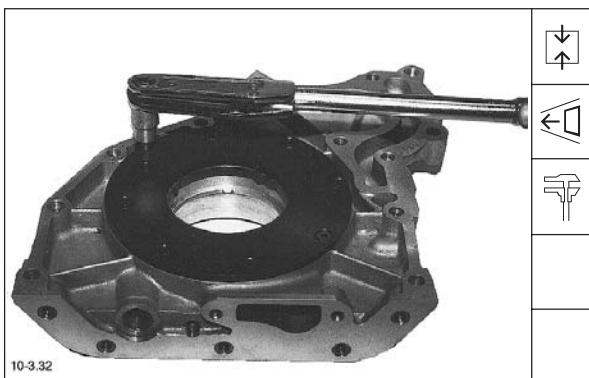

5. Schmierölpumpe einbauen und mit einem Drehmoment von **8 - 9 Nm** festdrehen.



English	Français	Italiano
3.1 Pressure control valve BFM 1013: Position assembly tool on compression spring. Fit valve spring tensioning device.	3.1 Soupape de régulation de pression BFM 1013: Placer outil de montage sur le ressort de pression.	3.1 Valvola di regolazione della pressione su BFM 1013: applicare l'attrezzo di montaggio sulla molla di compressione.
3.2 Press down compression spring and remove holding plate.	3.2 Comprimer le ressort de pression et retirer le disque de maintien.	3.2 Spingere in basso la molla di compressione ed estrarre la rondella di ritegno
4. Replace complete front cover in case of visible wear or damage to individual components.	4. En cas d'usure visible ou si les pièces détachées sont endommagées remplacer le couvercle avant complet.	4. Nel caso in cui si rilevi che qualche particolare è usurato o danneggiato, l'intero coperchio anteriore deve venire sostituito.
5. Install lube oil pump and secure with a torque of <b>8 - 9 Nm</b> .	5. Monter la pompe à huile et la serrer au couple de <b>8 - 9 Nm</b> .	5. Installare la pompa dell'olio e serrarne le viti con una coppia di <b>8 - 9 Nm</b> .

English	Français	Italiano
6. Fit BFM 1012 pressure control valve and tighten with a torque of <b>40 ± 4 Nm</b> .	6. Monter la soupape de régulation de pression du BFM 1012.  Serrer la soupape de régulation de pression au couple de <b>40 ± 4 Nm</b> .	6. Installare la valvola di regolazione della pressione sul BFM 1012.  Bloccare la valvola di regolazione della pressione con una coppia di serraggio di <b>40 ± 4 Nm</b> .
6.1 Fit BFM 1013 pressure control valve: Press down compression spring and insert holding plate.	6.1 Monter la soupape de régulation de pression du BFM 1013: comprimer le ressort de pression et retirer le disque de maintien.	6.1 Installare la valvola di regolazione della pressione sul BFM 1013: spingere in basso la molla di compressione ed inserire la rondella di ritegno.
<b>Note:</b> Watch out that holding plate is properly seated.	<b>Nota:</b> veiller à ce que le disque de maintien repose bien dans son logement.	<b>Nota:</b> Controllare che la rondella di ritegno entri nella sua sede.
7. Fit shaft seal with assembly tool.	7. Monter le joint d'arbre à l'aide du dispositif de montage.	7. Servendosi dell'apposito attrezzo, montare l'anello paraolio.
<b>Note:</b> Prior to assembly apply dehydrated lubricant onto shaft seal.	<b>Nota:</b> avant de le monter enduire le joint d'arbre de lubrifiant anhydre.	<b>Nota:</b> Prima di montare l'anello paraolio lubrificarlo con un grasso anidro.

**Deutsch**

**Werkstatthandbuch BFM 1012/E, BFM 1013/E**

6. Druckregelventil BFM 1012 einbauen.

Druckregelventil mit einem Drehmoment von  $40 \pm 4$  Nm festdrehen.



6.1 Druckregelventil BFM 1013 einbauen:  
 Druckfeder hinunterdrücken und Haltescheibe einsetzen.

**Hinweis:** Auf richtigen Sitz der Haltescheibe achten.

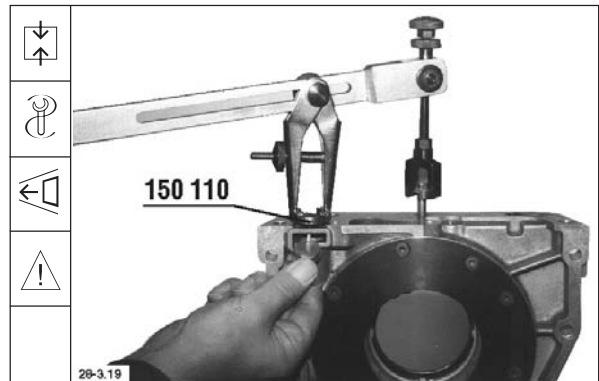

7. Wellendichtring mit Montagevorrichtung montieren.

**Hinweis:** Vor Montage Wellendichtring mit wasserfreiem Schmiermittel bestreichen.

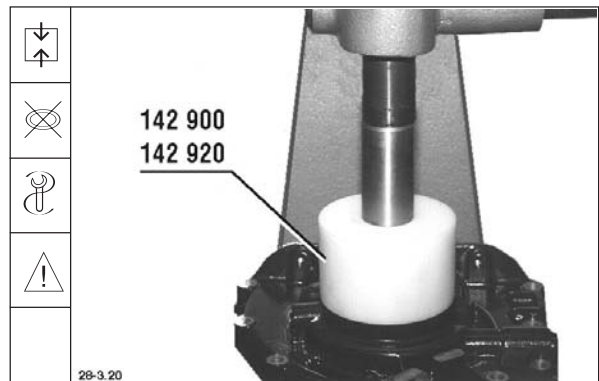

**Bauteile instand setzen**  
**Repair of components**  
**Mise en état des composants**  
**Riparazione dei componenti**

---

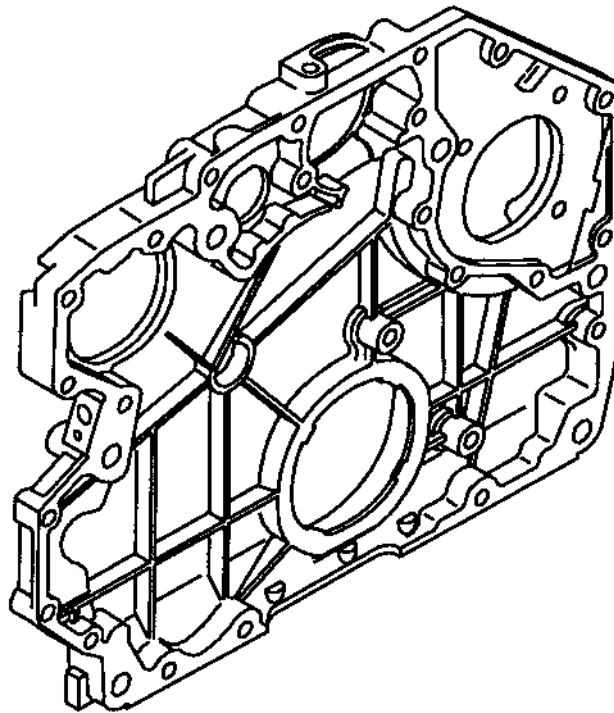

English	Français	Italiano
<p><b>Special tool required:</b></p> <p>Assembly tool BFM 1012 _____ 142 890 BFM 1013 _____ 142 910</p>	<p><b>Outillage spécial:</b></p> <p>Outil de montage BFM 1012 _____ 142 890 BFM 1013 _____ 142 910</p>	<p><b>Attrezzi speciali:</b></p> <p>Attrezzi di montaggio: BFM 1012 _____ 142 890 BFM 1013 _____ 142 910</p>
<p>1. Drive out shaft seal.</p>	<p>1. Chasser le joint d'arbre.</p>	<p>1. Estrarre l'anello raschiaolio.</p>
<p>2. Press out cover.</p>	<p>2. Extraire le couvercle.</p>	<p>2. Estrarre il coperchio.</p>
<p><b>Note:</b> Watch out for spacer sleeves.</p>	<p><b>Nota:</b> veiller aux douilles d'écartement.</p>	<p><b>Nota:</b> Fare attenzione alle bussole distanziatrici</p>
<p>3. Remove speed sensor if any.</p>	<p>3. Selon l'équipement du moteur, démonter le capteur tachymétrique.</p>	<p>3. Se installato, smontare il sensore dei giri.</p>

Deutsch

Werkstatthandbuch BFM 1012/E, BFM 1013/E

Spezialwerkzeuge:

Montagewerkzeug BFM 1012 \_\_\_\_\_ 142 890  
BFM 1013 \_\_\_\_\_ 142 910

1. Wellendichtring austreiben.

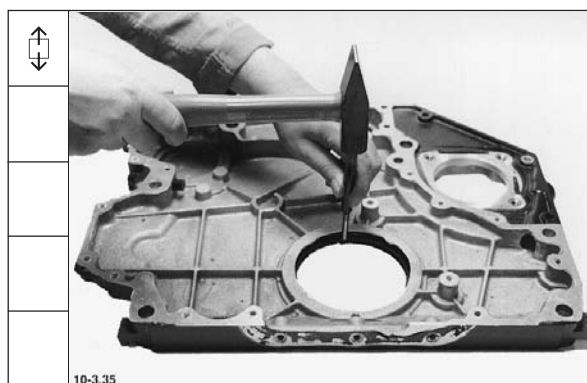

2. Verschlußdeckel ausdrücken.

**Hinweis:** Auf Abstandshülsen achten.

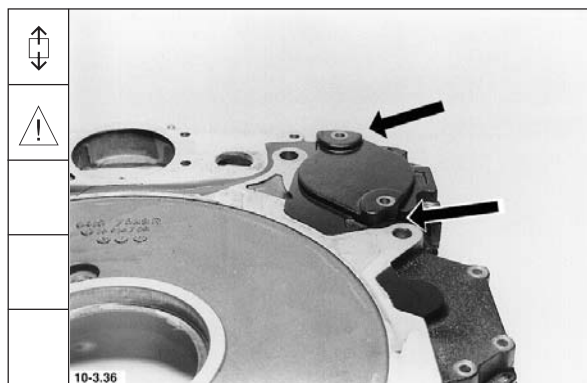

3. Falls vorhanden, Drehzahlgeber ausbauen.



Werkstatthandbuch BFM 1012/E, BFM 1013/E

Deutsch

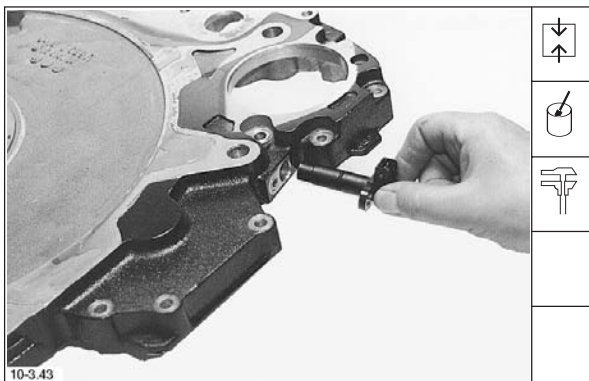
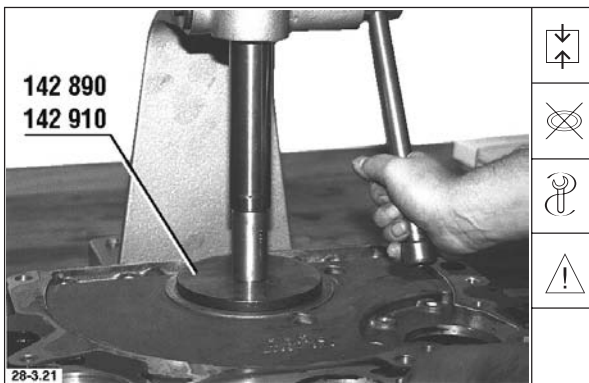
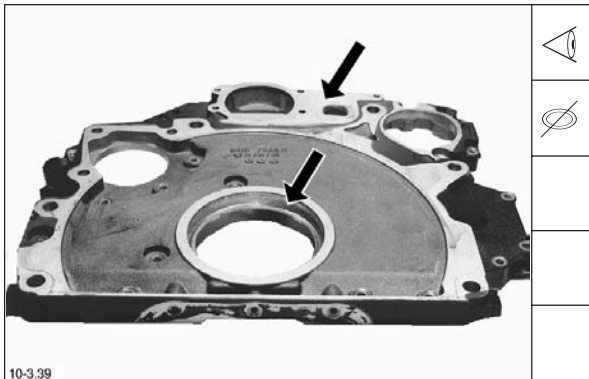

4. Räderkasten sichtprüfen, ggf. austauschen.

5. Wellendichtring mit Montagevorrichtung montieren.

**Hinweis:** Vor Montage Wellendichtring mit wasserfreiem Schmiermittel bestreichen.

6. Falls vorhanden, Drehzahlgeber einbauen. Schraube mit einem Drehmoment von  $9 \pm 1 \text{ Nm}$  festdrehen.



English	Français	Italiano
4. Inspect timing chest, replace if necessary.	4. Contrôler visuellement le carter de distribution, au besoin le remplacer.	4. Controllare la scatola della distribuzione e sostituirla qualora necessario.
5. Fit shaft seal with assembly tool.	5. Monter le joint d'arbre à l'aide d'un dispositif de montage.	5. Servendosi dell'apposito dispositivo, montare l'anello paraolio.
<b>Note:</b> Prior to assembly apply dehydrated lubricant onto shaft seal.	<b>Nota:</b> avant de le monter enduire le joint d'arbre d'un lubrifiant anhydre.	<b>Nota:</b> Prima di montarlo, lubrificare l'anello paraolio con del grasso anidro.
6. Install speed sensor, if any. Tighten bolt with a torque of <b>9 ± 1 Nm</b> .	6. Si le moteur en est doté d'un, monter le capteur tachymétrique. Serrer les vis au couple de <b>9 ± 1 Nm</b> .	6. Se è previsto, montare il sensore dei giri. Serrarne la vite con una coppia di <b>9 ± 1 Nm</b> .

**Bauteile instand setzen**  
**Repair of components**  
**Mise en état des composants**  
**Riparazione dei componenti**

---

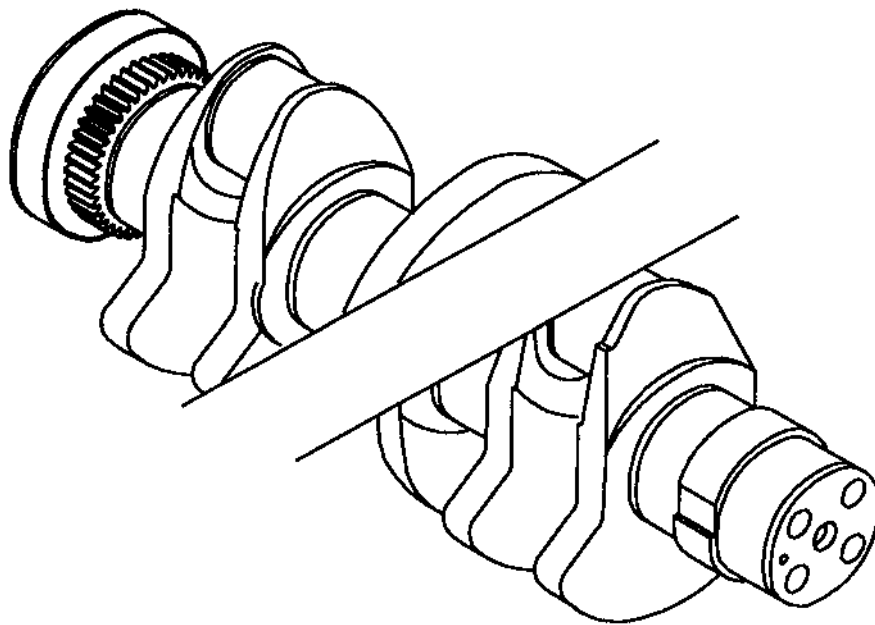

English	Français	Italiano
<b>BFM 1012 crankshaft</b>	<b>Vilebrequin BFM 1012</b>	<b>Albero a gomiti BFM 1012</b>
1. Chuck crankshaft up on prism stand.	1. Serrer le vilebrequin sur un support prismatique.	1. Collocare l'albero a gomiti sui supporti a prisma.
2. Schematic for gauging main bearing journals at points „1“ and „2“ in planes „a“ and „b“.	2. Schéma de relevé des cotes des tourillons aux points „1“ et „2“ dans l'axe „a“ et „b“.	2. Schema di misurazione dei perni di banco nei punti "1" e "2" sui piani "a" e "b".
Journal diameter <b>74.00<sup>-0,02</sup> mm</b> Each undersize <b>0.25 mm</b> Limit for undersize <b>73.50<sup>-0,02</sup> mm</b> Wear limit: Journal ovality <b>0.01 mm</b>	Diamètre des soies <b>74,00<sup>-0,02</sup> mm</b> Cote de rectification <b>0,25 mm</b> Cote limite de rectification <b>73,50<sup>-0,02</sup> mm</b> Limite d'usure : ovalisation des soies <b>0,01 mm</b>	Diametro del perno <b>74,00<sup>-0,02</sup> mm</b> Grado di minorazione <b>0,25 mm</b> Misura limite di minorazione <b>73,50<sup>-0,02</sup> mm</b> Limite di usura: Ovalizzazione del perno <b>0,01 mm</b>
3. Gauge thrust bearing journal width.	3. Relever la largeur du tourillon du palier de butée.	3. Misurare la larghezza del perno del cuscinetto di centraggio.
Journal width <b>36.00<sup>+0,04</sup> mm</b> 1st oversize stage <b>0.4 mm</b> Limit for oversize <b>36.44 mm</b>	Largeur tourillon <b>36,00<sup>+0,04</sup> mm</b> 1. Degré de surmesure <b>0,4 mm</b> Cote limite de rectification <b>36,44 mm</b>	Larghezza del perno <b>36,00<sup>+0,04</sup> mm</b> Primo grado di maggiorazione <b>0,4 mm</b> Misura limite di maggiorazione <b>36,44 mm</b>
4. Gauge crankpins.	4. Effectuer un relevé des cotes des manetons.	4. Misurare il perno di banco
Crankpin diameter <b>58.00<sup>-0,02</sup> mm</b> Each undersize <b>0.25 mm</b> Limit for undersize <b>57.50<sup>-0,02</sup> mm</b> Wear limit: Crankpin ovality <b>0.01 mm</b>	Diamètre des soies <b>58,00<sup>-0,02</sup> mm</b> Cote de rectification respective <b>0,25 mm</b> Cote limite de rectification <b>57,50<sup>-0,02</sup> mm</b> Limite d'usure ovalisation des soies <b>0,01 mm</b>	Diametro del perno <b>58,00<sup>-0,02</sup> mm</b> Grado di minorazione <b>0,25 mm</b> Misura limite di minorazione <b>57,50<sup>-0,02</sup> mm</b> Limite di usura: Ovalizzazione del perno <b>0,01 mm</b>

**Deutsch**

**Werkstatthandbuch BFM 1012/E, BFM 1013/E**

**Kurbelwelle BFM 1012**

1. Kurbelwelle in Prismen aufnehmen.

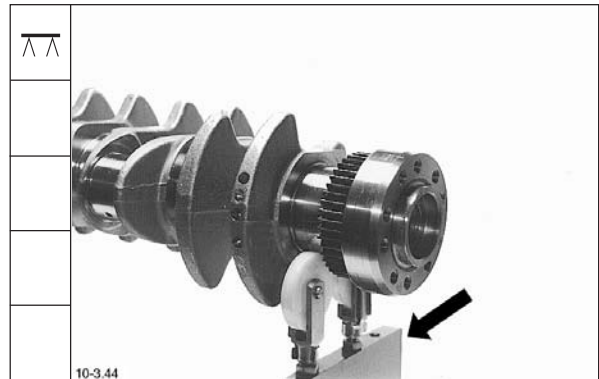

2. Schema zum Vermessen der Hauptlagerzapfen an den Stellen "1" und "2" in der Ebene "a" und "b".

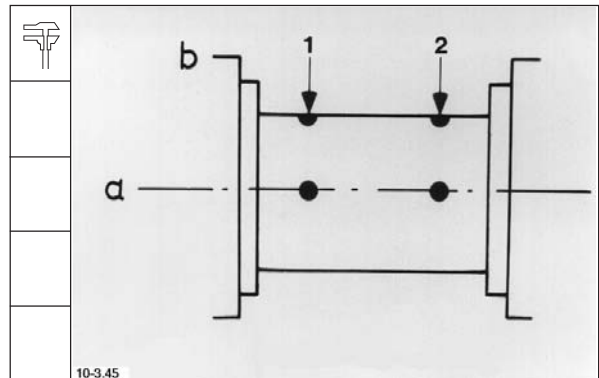

Zapfendurchmesser	<b>74,00</b>	$-0,02$	mm
Untermaßstufe	<b>0,25</b>		mm
Grenzmaß für Untermaßstufe	<b>73,50</b>	$-0,02$	mm
Verschleißgrenze:			
Zapfenunrundheit	<b>0,01</b>		mm

3. Breite des Paßlagerzapfens messen.

Zapfenbreite	<b>36,00</b>	$+0,04$	mm
1. Übermaßstufe	<b>0,4</b>		mm
Grenzmaß für Übermaßstufe	<b>36,44</b>		mm

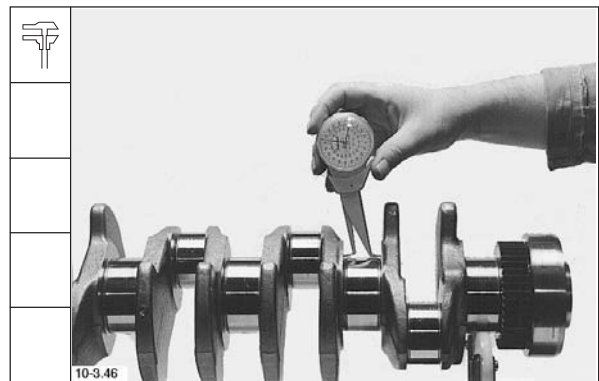

4. Hubzapfen messen.

Zapfendurchmesser	<b>58,00</b>	$-0,02$	mm
Untermaß je Stufe	<b>0,25</b>		mm
Grenzmaß für Untermaßstufe	<b>57,50</b>	$-0,02$	mm
Verschleißgrenze:			
Zapfenunrundheit	<b>0,01</b>		mm

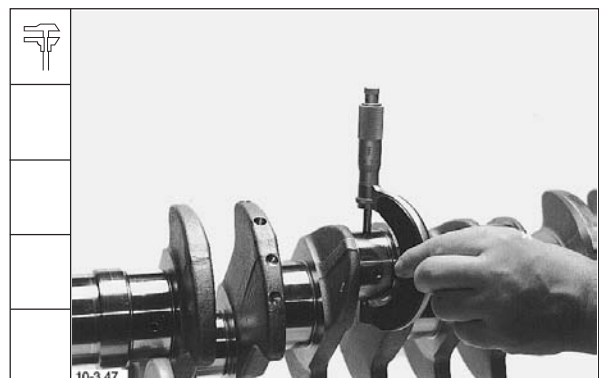

Werkstatthandbuch BFM 1012/E, BFM 1013/E

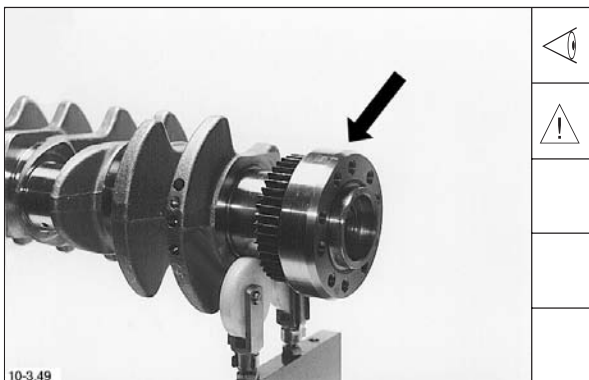
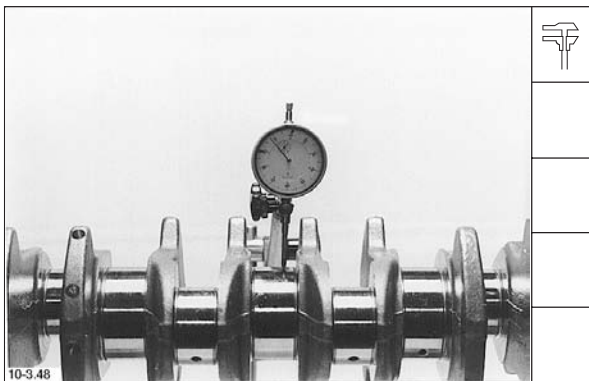

Deutsch

5. Kurbelwelle auf Rundlauf prüfen

Abweichung max.: BF4M = **0,07 mm**  
BF6M = **0,10 mm**

6. Laufflächen der Wellendichtringe sichtbar prüfen.

**Hinweis:** Bei verschlissener Kurbelwelle besteht die Möglichkeit, die Kurbelwelle in unseren Service-Centern als Austauschwelle zu beziehen oder instandsetzen zu lassen.

English	Français	Italiano
<p>5. Check crankshaft for true running.</p> <p>Out of roundness max.: BF4M = <b>0.07 mm</b> BF6M = <b>0.10 mm</b></p> <p>6. Inspect running surfaces of shaft seals.</p> <p><b>Note:</b> If the crankshaft is worn, it is possible to purchase an exchange crankshaft from our service centers or to have it repaired.</p>	<p>5. Vérifier la concentricité du vilebrequin.</p> <p>Ecart maxi BF4M = <b>0,07 mm</b> BF6M = <b>0,10 mm</b></p> <p>6. Contrôle visuel des surfaces de frottement des joints d'arbre.</p> <p><b>Nota:</b> en cas d'usure de vilebrequin vous avez la possibilité de le faire remplacer dans nos Service Centers ou de le réparer.</p>	<p>5. Controllare la rotazione concentrica dell'albero a gomiti</p> <p>Scostamento massimo: BF4M = <b>0,07 mm</b> BF6M = <b>0,10 mm</b></p> <p>6. Controllare le superfici d'appoggio degli anelli paraolio.</p> <p><b>Nota:</b> Nel caso in cui l'albero a gomiti sia usurato esiste la possibilità di ricevere l'albero a gomiti come albero di rotazione nei nostri centri di servizio, oppure di farlo riparare.</p>

English	Français	Italiano
<b>BFM 1013 crankshaft</b>	<b>Vilebrequin BFM 1013</b>	<b>Albero a gomiti BFM 1013</b>
1. Chuck crankshaft up on prism stand.	1. Serrer le vilebrequin sur un support prismatique.	1. Collocare l'albero a gomiti sui supporti a prisma.
2. Schematic for gauging main bearing journals at points „1“ and „2“ in planes „a“ and „b“.	2. Schéma de relevé des cotes des tourillons aux points „1“ et „2“ dans l'axe „a“ et „b“.	2. Schema di misurazione dei perni di banco nei punti "1" e "2" sui piani "a" e "b".
Journal diameter <b>85,00</b> $^{0}_{-0,02}$ mm Each undersize <b>0,25</b> mm Limit for undersize <b>84,50</b> $^{0}_{-0,02}$ mm Wear limit: Journal ovality <b>0,01</b> mm	Diamètre des soies <b>85,00</b> $^{0}_{-0,02}$ mm Cote de rectification <b>0,25</b> mm Cote limite de rectification <b>84,50</b> $^{0}_{-0,02}$ mm Limite d'usure : ovalisation des soies <b>0,01</b> mm	Diametro del perno <b>85,00</b> $^{0}_{-0,02}$ mm Grado di minorazione <b>0,25</b> mm Misura limite di minorazione <b>84,50</b> $^{0}_{-0,02}$ mm Limite di usura: Ovalizzazione del perno <b>0,01</b> mm
3. Gauge thrust bearing journal width.	3. Relever la largeur du tourillon du palier de butée.	3. Misurare la larghezza del perno del cuscinetto di centraggio.
Journal width <b>38,00</b> $^{+0,06}$ mm 1st oversize stage <b>0,4</b> mm Limit for oversize <b>38,46</b> mm	Largeur tourillon <b>38,00</b> $^{+0,06}$ mm 1. Degré de surmesure <b>0,4</b> mm Cote limite de rectification <b>38,46</b> mm	Larghezza del perno <b>38,00</b> $^{+0,06}$ mm Primo grado di maggiorazione <b>0,4</b> mm Misura limite di maggiorazione <b>38,46</b> mm
4. Gauge crankpins.	4. Effectuer un relevé des cotes des manetons.	4. Misurare il perno di banco
Crankpin diameter <b>68,00</b> $^{0}_{-0,02}$ mm Each undersize <b>0,25</b> mm Limit for undersize <b>67,50</b> $^{0}_{-0,02}$ mm Wear limit: Crankpin ovality <b>0,01</b> mm	Diamètre des soies <b>68,00</b> $^{0}_{-0,02}$ mm Cote de rectification respective <b>0,25</b> mm Cote limite de rectification <b>67,50</b> $^{0}_{-0,02}$ mm Limite d'usure: ovalisation des soies <b>0,01</b> mm	Diametro del perno <b>68,00</b> $^{0}_{-0,02}$ mm Grado di minorazione <b>0,25</b> mm Misura limite di minorazione <b>67,50</b> $^{0}_{-0,02}$ mm Limite di usura: Ovalizzazione del perno <b>0,01</b> mm



**Deutsch**

**Werkstatthandbuch BFM 1012/E, BFM 1013/E**

**Kurbelwelle BFM 1013**

1. Kurbelwelle in Prismen aufnehmen.

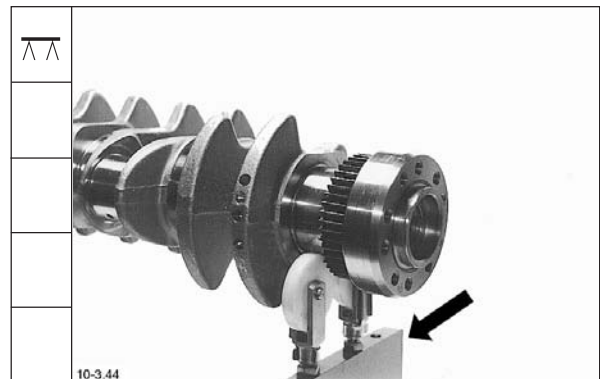

2. Schema zum Vermessen der Hauptlagerzapfen an den Stellen "1" und "2" in der Ebene "a" und "b".

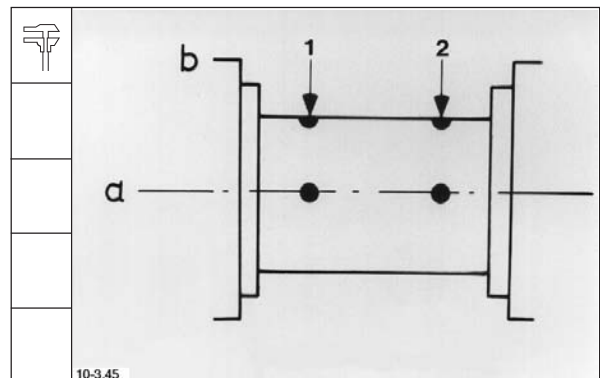

Zapfendurchmesser	<b>85,00</b>	$-0,02$	mm
Untermaßstufe	<b>0,25</b>		mm
Grenzmaß für Untermaßstufe	<b>84,50</b>	$-0,02$	mm
Verschleißgrenze:			
Zapfenunrundheit	<b>0,01</b>		mm

3. Breite des Paßlagerzapfens messen

Zapfenbreite	<b>38,00</b>	$+0,06$	mm
1. Übermaßstufe	<b>0,4</b>		mm
Grenzmaß für Übermaßstufe	<b>38,46</b>		mm

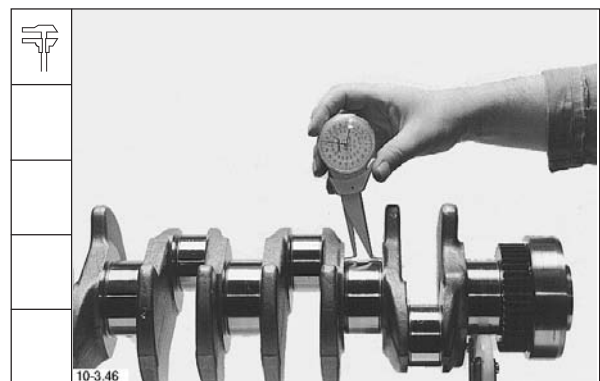

4. Hubzapfen messen

Zapfendurchmesser	<b>68,00</b>	$-0,02$	mm
Untermaß je Stufe	<b>0,25</b>		mm
Grenzmaß für Untermaßstufe	<b>67,50</b>	$-0,02$	mm
Verschleißgrenze:			
Zapfenunrundheit	<b>0,01</b>		mm

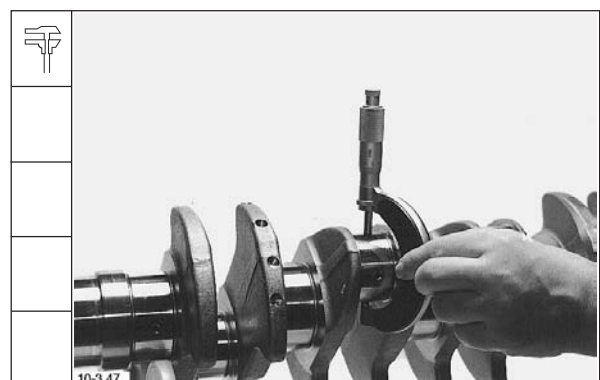

Werkstatthandbuch BFM 1012/E, BFM 1013/E

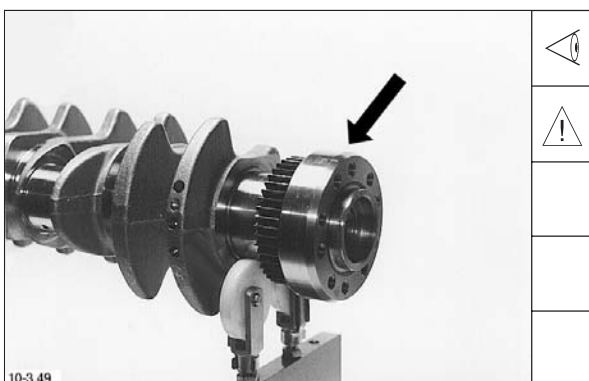
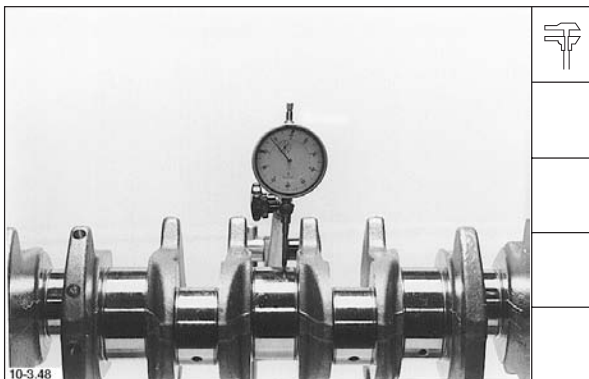

Deutsch

5. Kurbelwelle auf Rundlauf prüfen

Abweichung max.: BF4M = **0,07 mm**  
BF6M = **0,10 mm**

6. Laufflächen der Wellendichtringe sichtbar prüfen.

**Hinweis:** Bei verschlissener Kurbelwelle besteht die Möglichkeit, die Kurbelwelle in unseren Service-Centern als Austauschwelle zu beziehen oder instandsetzen zu lassen.

English	Français	Italiano
<p>5. Check crankshaft for true running.</p> <p>Out of roundness max.: BF4M = <b>0.07 mm</b> BF6M = <b>0.10 mm</b></p>	<p>5. Vérifier la concentricité du vilebrequin.</p> <p>Ecart maxi: BF4M = <b>0,07 mm</b> BF6M = <b>0,10 mm</b></p>	<p>5. Controllare la rotazione concentrica dell'albero a gomiti</p> <p>Scostamento massimo: BF4M = <b>0,07 mm</b> BF6M = <b>0,10 mm</b></p>
<p>6. Inspect running surfaces of shaft seals.</p> <p><b>Note:</b> If the crankshaft is worn, it is possible to purchase an exchange crankshaft from our service centers or to have it repaired.</p>	<p>6. Contrôle visuel des surfaces de frottement des joints d'arbre.</p> <p><b>Nota:</b> en cas d'usure de vilebrequin vous avez la possibilité de le faire remplacer dans nos Service Centers ou de le réparer.</p>	<p>6. Controllare le superfici d'appoggio degli anelli paraolio.</p> <p><b>Nota:</b> Nel caso in cui l'albero a gomiti sia usurato esiste la possibilità di ricevere l'albero a gomiti come albero di rotazione nei nostri centri di servizio, oppure di farlo riparare.</p>

**Bauteile instand setzen**  
**Repair of components**  
**Mise en état des composants**  
**Riparazione dei componenti**

---

**Starterzahnkranz/Schwungrad**  
**Starter ring gear**  
**Couronne du volant/volant**  
**Corona dentata/Volano**

**Bauteile instandsetzen**  
**Repair of components**  
**Mise en état des composants**  
**Riparazione dei componenti**

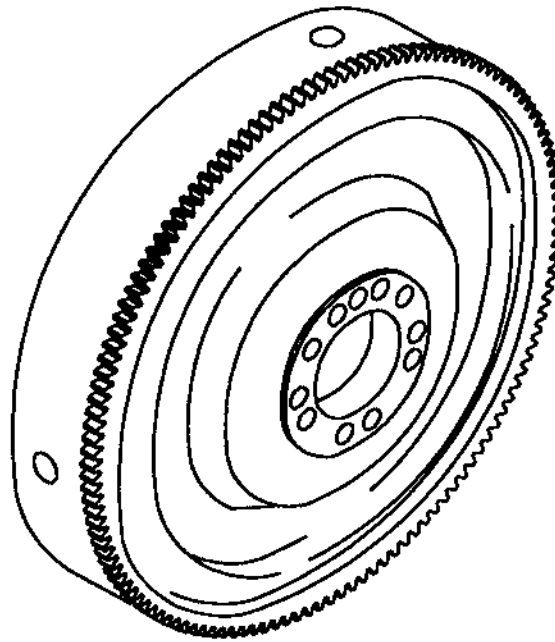

**English**

1. Drill ring gear apart.

**Note:** Make sure not to damage flywheel.

2. Remove ring gear.

3. Clean flywheel and inspect at supporting flange.

4. Heat ring gear to max. **210 °C**. Place ring gear in position and bring to stop at flange.

**Français**

1. Percer la couronne dentée.

**Nota:** ne pas endommager le volant moteur.

2. Oter la couronne.

3. Nettoyer le volant moteur et contrôler visuellement la collerette d'appui.

4. Réchauffer la couronne dentée à **210 °C** maximum.  
La mettre en place de manière à ce qu'elle soit en position d'appui sur la collerette.

**Italiano**

1. Forare la corona dentata.

**Nota:** Evitare di danneggiare il volano.

2. Smontare la corona dentata.

3. Pulire il volano e controllare la sede della corona dentata.

4. Riscaldare a non più di **210 °C** la corona dentata. Appoggiare la corona dentata sulla sua sede e farvela entrare.

**Deutsch**

**Werkstatthandbuch BFM 1012/E, BFM 1013/E**

1. Zahnkranz aufbohren.

**Hinweis:** Schwungrad nicht beschädigen.

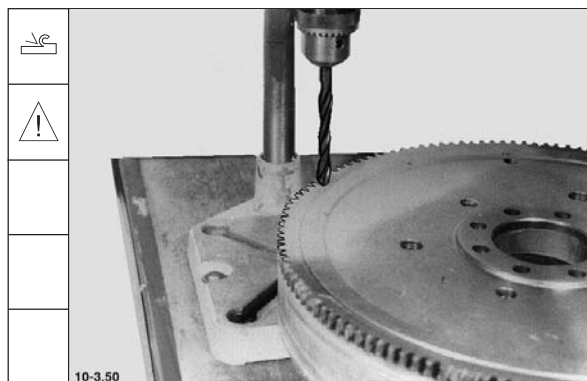

2. Zahnkranz entfernen.



3. Schwungrad reinigen und am Auflagebund sichtprüfen.



4. Zahnkranz auf max. **210 °C** erwärmen.  
Zahnkranz auflegen und am Bund zur Anlage bringen.

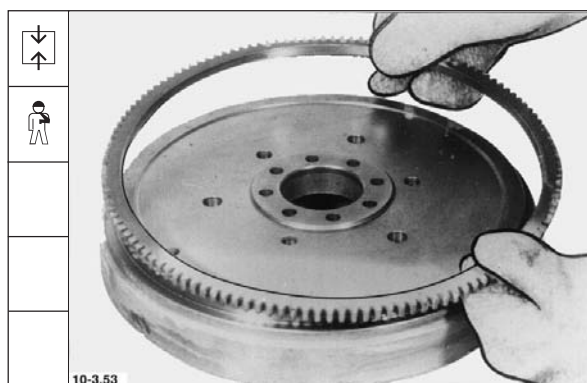

**Bauteile instand setzen**  
**Repair of components**  
**Mise en état des composants**  
**Riparazione dei componenti**

---



**Pleuelstange**  
**Connecting rod**  
**Bielle**  
**Biella**

**Bauteile instandsetzen**  
**Repair of components**  
**Mise en état des composants**  
**Riparazione dei componenti**

---

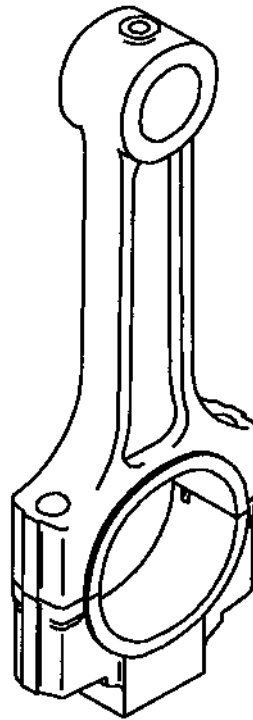

English	Français	Italiano
<b>Special tool required:</b>	<b>Outillage spécial:</b>	<b>Attrezzi speciali:</b>
Assembly tool for small end bush	Dispositif de montage de bague de pied de bielle	Dispositivo di montaggio per la bronzina del piede di biella:
BFM 1012 _____ 131 070	BFM 1012 _____ 131 070	BFM 1012 _____ 131 070
BFM 1013 _____ 131 090	BFM 1013 _____ 131 090	BFM 1013 _____ 131 090
1. Set internal dial gauge:	1. Régler l'appareil de contrôle	1. Predisporre il comparatore per interni.
BFM 1012 to <b>34 mm</b> dia.	BFM 1012 <b>34 mm.</b>	BFM 1012 su <b>34 mm</b>
BFM 1013 to <b>42 mm</b> dia.	BFM 1013 <b>42 mm.</b>	BFM 1013 su <b>42 mm</b>
2. Gauge small end bush at points „1“ and „2“ in planes „a“ and „b“.	2. Procéder à un relevé des cotes de la bague de pied de bielle aux points „1“ et „2“ sur les axes „a“ et „b“.	2. Misurare la bronzina del piede di biella nei punti "1" e "2" sui piani "a" e "b"
3. Gauge.	3. Mesurer.	3. Misurare la bronzina del piede di biella già inserita nella sua sede.
Small end bush pressed in	Valeur de consigne de la bague de pied de bielle serrée	Valori nominali:
Specified value	Valeur de consigne	BFM 1012 <b>34<sup>+0,035</sup> mm</b>
BFM 1012 <b>34<sup>+0,035</sup> mm</b>	BFM 1012 <b>34<sup>+0,035</sup> mm</b>	BFM 1013 <b>42<sup>+0,05</sup> mm</b>
BFM 1013 <b>42<sup>+0,05</sup> mm</b>	BFM 1013 <b>42<sup>+0,05</sup> mm</b>	
Wear limit:	Limite d'usure :	Limite d'usura:
Small end bush clearance <b>0.08mm</b>	jeu dans pied de bielle <b>0,08 mm</b>	Gioco dello spinotto <b>0,08 mm</b>
4. Replace small end bush if necessary.	4. Au besoin remplacer la bague de pied de bielle.	4. All'occorrenza sostituire la bronzina del piede di biella.
Bore for small end bush:	Alésage bague de pied de bielle:	Foro per la bronzina del piede di biella:
BFM 1012 = <b>37 + 0.02 mm</b>	BFM 1012 <b>37 + 0,02 mm</b>	BFM 1012 <b>37 + 0,02 mm</b>
BFM 1013 = <b>45.5 + 0.02 mm</b>	BFM 1013 <b>45,5 + 0,02 mm</b>	BFM 1013 <b>45,5 + 0,02 mm</b>
Small end bush Outer diameter:	Bague de pied de bielle diamètre extérieur:	Diametro esterno della bronzina del piede di biella:
BFM 1012 <b>37<sup>+0,11</sup> mm</b>	BFM 1012 <b>37<sup>+0,11</sup> mm</b>	BFM 1012 <b>37<sup>+0,11</sup> mm</b>
BFM 1013 <b>45,5<sup>+0,12</sup> mm</b>	BFM 1013 <b>45,5<sup>+0,12</sup> mm</b>	BFM 1013 <b>45,5<sup>+0,12</sup> mm</b>

**Deutsch**

**Werkstatthandbuch BFM 1012/E, BFM 1013/E**

**Spezialwerkzeuge:**

Montagevorrichtung für Kolbenbolzenbuchse BFM 1012 \_\_\_\_\_ 131 070  
 BFM 1013 \_\_\_\_\_ 131 090

1. Innenmeßgerät einstellen.

BFM 1012 auf **34 mm**

BFM 1013 auf **42 mm**



10-3.54

2. Kolbenbolzenbuchse an den Punkten "1" und "2" in der Ebene "a" und "b" messen.

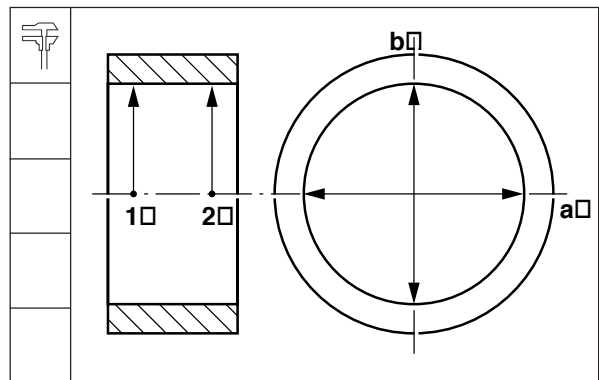

3. Messen.

Kolbenbolzenbuchse eingepreßt

Sollwert:

BFM 1012  **$34 \pm 0,025$  mm**

BFM 1013  **$42 \pm 0,04$  mm**

Verschleißgrenze:

Kolbenbolzenspiel **0,08 mm**



10-3.56

4. Bei Bedarf Kolbenbolzenbuchse auswechseln.

Bohrung für Kolbenbolzenbuchse:

BFM 1012  **$37 + 0,02$  mm**

BFM 1013  **$45,5 + 0,02$  mm**

Kolbenbolzenbuchse

Außendurchmesser:

BFM 1012  **$37 \pm 0,11$  mm**

BFM 1013  **$45,5 \pm 0,12$  mm**

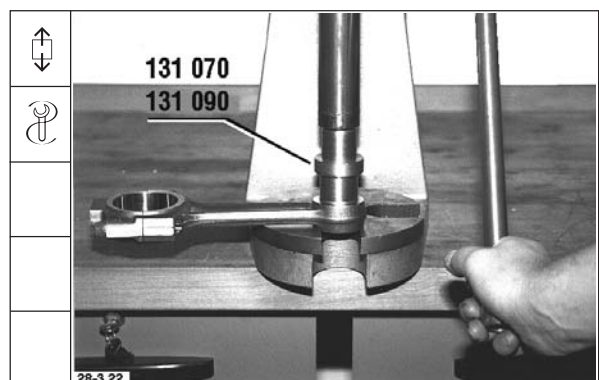

28-3.22

Werkstatthandbuch BFM 1012/E, BFM 1013/E

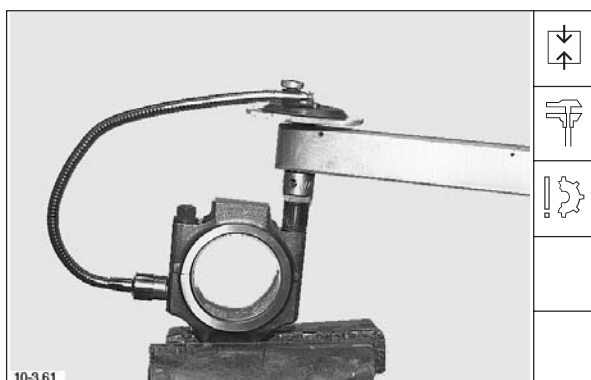
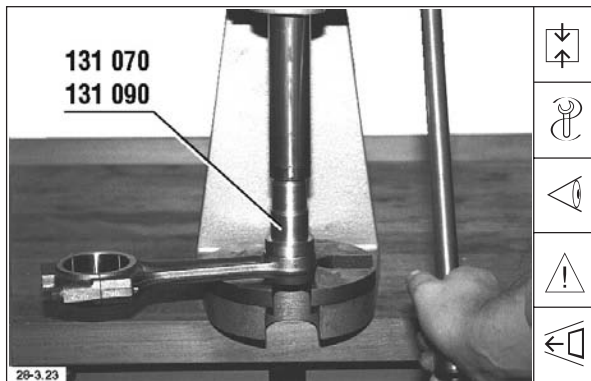

Deutsch

5. Kolbenbolzenbuchse bündig einpressen.

**Hinweis:** Schmierölbohrung der Kolbenbolzenbuchse und der Pleuelstange müssen übereinstimmen.

6. Kolbenbolzenbuchse nach dem Einpressen ausspindeln.

BFM 1012 auf	$34^{+0,035}_{+0,025}$ mm
BFM 1013 auf	$42^{+0,05}_{+0,04}$ mm

7. Pleuellagerdeckel zuordnen.

**Hinweis:** Auf Vorhandensein der Spannstifte achten.

8. Pleuellagerdeckel montieren. Schrauben nach Anziehvorschrift festdrehen.

Vorspannwert:	<b>30 Nm</b>
1. Nachspannwinkel	<b>60°</b>
2. Nachspannwinkel	
BFM 1012	<b>30°</b>
BFM 1013	<b>60°</b>

English	Français	Italiano
<p>5. Press in small end bush flush.</p> <p><b>Note:</b> Lube oil bores of small end bush and connecting rod must be in line.</p>	<p>5. Insérer jusqu'à affleurement bague du pied de bielle.</p> <p><b>Nota:</b> les trous de passage d'huile de la bague de pied de bielle et de la bielle doivent correspondre.</p>	<p>5. Inserire la bronzina del piede di biella nell'occhio di biella.</p> <p><b>Nota:</b> I fori di passaggio per l'olio sulla bronzina del piede di biella devono coincidere con quelli sulla biella stessa.</p>
<p>6. After pressing in, precision-bore small end bush on a fine boring mill.</p> <p>BFM 1012 to <math>34^{+0,035}_{-0,025}</math> mm            BFM 1013 to <math>42^{+0,05}_{-0,04}</math> mm</p>	<p>6. Après l'avoir insérée, usiner à la broche la bague du pied de bielle</p> <p>BFM 1012 <math>34^{+0,035}_{-0,025}</math> mm            BFM 1013 <math>42^{+0,05}_{-0,04}</math> mm</p>	<p>6. Dopo aver inserito completamente la bronzina del piede di biella, eseguirne l'alesatura.</p> <p>BFM 1012 <math>34^{+0,035}_{-0,025}</math> mm            BFM 1013 <math>42^{+0,05}_{-0,04}</math> mm</p>
<p>7. Make sure that cap mates with connecting rod.</p> <p><b>Note:</b> Make sure that dowel pins are fitted.</p>	<p>7. Bien positionner selon le numéro repère le chapeau de bielle.</p> <p><b>Nota:</b> veiller à ce que les goupilles de serrage soient bien en place.</p>	<p>7. Controllare la corrispondenza del cappello di biella.</p> <p><b>Nota:</b> Assicurarsi della presenza delle spine elastiche.</p>
<p>8. Mount bearing cap. Tighten bolts in accordance with specification.</p> <p>Initial tightening torque: <b>30 Nm</b>            1st tightening angle <b>60°</b>            2nd tightening angle            BFM 1012 <b>30°</b>            BFM 1013 <b>60°</b></p>	<p>8. Monter le chapeau de bielle. Serrer les écrous selon les préconisations de serrage.</p> <p>Valeur de préserrage : <b>30 Nm</b>            1er angle de serrage: <b>60°</b>            2ème angle de serrage:            BFM 1012 <b>30°</b>            BFM 1013 <b>60°</b></p>	<p>8. Montare il cappello di biella ed avvitare le viti attenendosi alle prescrizioni di serraggio.</p> <p>Valore del preserraggio <b>30 Nm</b>            l'angolo di ripasso <b>60°</b>            Il angolo di ripasso:            BFM 1012 <b>30°</b>            BFM 1013 <b>60°</b></p>

English	Français	Italiano
<p>9. Set internal dial gauge:                      BFM 1012 to dia. <b>61.6 mm</b>                      BFM 1013 to dia. <b>72.5 mm</b></p>	<p>9. Régler l'appareil de mesure :                      BFM 1012 <b>61,6 mm</b>                      BFM 1013 <b>72,5 mm</b></p>	<p>9. Registrare il comparatore per interni.                      BFM 1012 su <b>61,6 mm</b>                      BFM 1013 su <b>72,5 mm</b></p>
<p>10. Schematic for gauging big end bearing bore at points „1“ and „2“ in planes „a“ and „b“.</p> <p>Bore for big end bearing:                      BFM 1012 <b>61.6 + 0.02 mm</b>                      BFM 1013 <b>72.5 + 0.02 mm</b></p>	<p>10. Schéma de mesurage de l'alésage de coussinet de bielle aux points „1“ et „2“ au niveau des plans „a“ et „b“</p> <p>Alésage des coussinets de bielle                      BFM 1012 <b>61,6 + 0,02 mm</b>                      BFM 1013 <b>72,5 + 0,02 mm</b></p>	<p>10. Schema di misurazione del foro del cuscinetto di biella nei punti "1" e "2" sui piani "a" e "b".</p> <p>Foro per il cuscinetto di biella:                      BFM 1012 <b>61,6 + 0,02 mm</b>                      BFM 1013 <b>72,5 + 0,02 mm</b></p>
<p>11. If the gauge readings conform to the specified values, the necessary preload will be obtained after fitting the bearing shells.</p> <p><b>Note:</b> If the measured values deviate only slightly, additional measurements are to be carried out with new bearing shells fitted.</p>	<p>11. Si les mesures correspondent aux valeurs indiquées, c'est que après montage des coussinets la précontrainte est établie.</p> <p><b>Nota:</b> si, en revanche, les valeurs enregistrées ne s'écartent que faiblement, procéder à de nouvelles mesures avec les coussinets neufs.</p>	<p>11. Se i valori misurati corrispondono ai valori indicati, dopo essere stati montati i cuscinetti hanno il precarico necessario.</p> <p><b>Nota:</b> Se i valori misurati si discostano anche soltanto di poco, si dovranno eseguire nuove misurazioni dopo aver sostituito il cuscinetto.</p>
<p>12. Remove bearing cap and fit new bearing shells. Refit bearing cap. Tighten nuts in accordance with specification.</p> <p>Initial tightening torque: <b>30 Nm</b>                      1st tightening angle <b>60°</b>                      2nd tightening angle                      BFM 1012 <b>30°</b>                      BFM 1013 <b>60°</b></p>	<p>12. Déposer le chapeau de bielle et placer des coussinets neufs. Monter le chapeau de bielle. Serrer les écrous selon les préconisations de serrage.</p> <p>Valeur de préserrage : <b>30 Nm</b>                      1er angle de serrage <b>60°</b>                      2ème angle de serrage                      BFM 1012 <b>30°</b>                      BFM 1013 <b>60°</b></p>	<p>12. Smontare il cappello di biella, inserire il nuovo cuscinetto e rimontare il cappello di biella. Serrare le viti attenendosi alle prescrizioni di serraggio.</p> <p>Valore del preserraggio <b>30 Nm</b>                      l'angolo di ripasso <b>60°</b>                      Il angolo di ripasso:                      BFM 1012 <b>30°</b>                      BFM 1013 <b>60°</b></p>

**Deutsch**

**Werkstatthandbuch BFM 1012/E, BFM 1013/E**

9. Innenmeßgerät einstellen.  
 BFM 1012 auf **61,6 mm**  
 BFM 1013 auf **72,5 mm**



10. Schema zum Vermessen der Pleuellagerbohrung an den Punkten "1" und "2" der Ebene "a" und "b".
- Bohrung für Pleuellager:  
 BFM 1012 **61,6 + 0,02 mm**  
 BFM 1013 **72,5 + 0,02 mm**

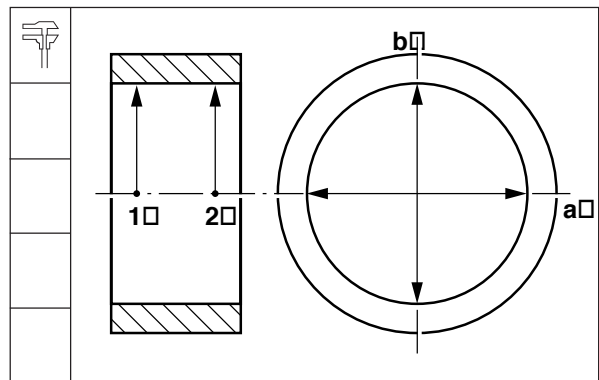

11. Entsprechen die Messungen den angegebenen Werten, ist nach dem Einbau von Lagerschalen die Vorspannung vorhanden.

**Hinweis:** Weichen die Meßwerte nur geringfügig ab, sind zusätzliche Messungen mit neuen Lagerschalen durchzuführen.

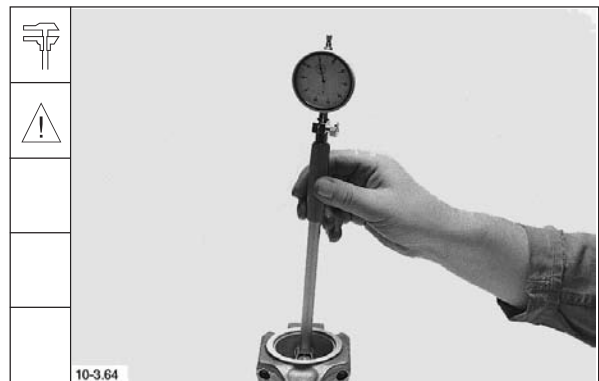

12. Pleuellagerdeckel abbauen und neue Lagerschalen einsetzen. Pleuellagerdeckel montieren. Schrauben nach Anziehvorschrift festdrehen.

- Vorspannwert: **30 Nm**  
 1. Nachspannwinkel **60°**  
 2. Nachspannwinkel:  
 BFM 1012 **30°**  
 BFM 1013 **60°**

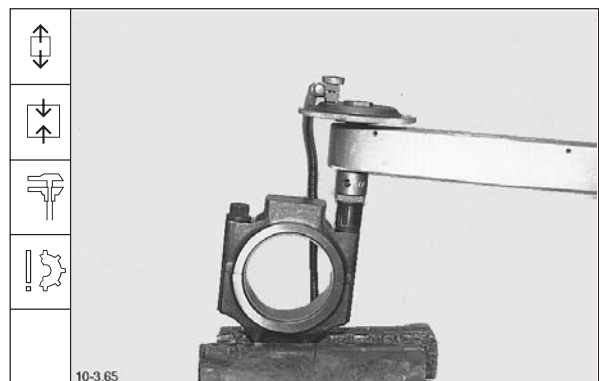

Werkstatthandbuch BFM 1012/E, BFM 1013/E



10-3.66

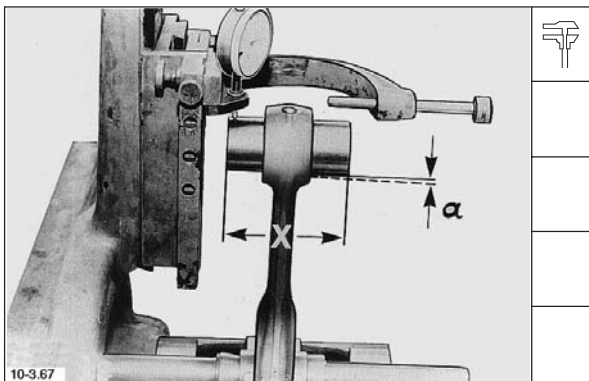

10-3.67

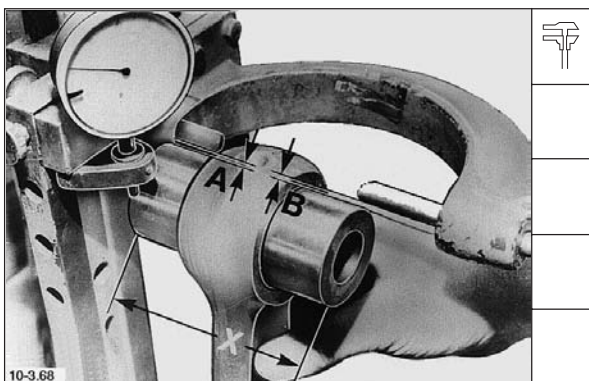

10-3.68

Deutsch

13. Innenmeßgerät einstellen. Lagerschalen an den Punkten "1" und "2" in den Ebenen "a" und "b" messen.

Pleuellagerschalen  
 Innendurchmesser:  
 BFM 1012 **58,03 - 58,07 mm**  
 BFM 1013 **68,036 - 68,076 mm**  
 Untermaß je Stufe: **0,25 mm**

Grenzmaß  
 für Untermaßstufe:  
 BFM 1012 **57,78 - 57,82 mm**  
 BFM 1013 **67,536 - 67,576 mm**

Verschleißgrenze:  
 Pleuellagerspiel **0,12 mm**

**Hinweis:** Liegen die Werte bis. max. **0,015 mm** über den Lagertoleranzen, kann die Pleuelstange weiter verwendet werden. Wird der Grenzwert überschritten, Pleuelstange austauschen.

14. Pleuelstange ohne Lagerschalen auf einem Pleuelprüfgerät prüfen.-

14.1 auf Parallelität:

Zulässige Abweichung **a = 0,05 mm**  
 bei einem Abstand von **x = 100 mm**

14.2 auf Winkligkeit:

Zulässige Abweichung "A" zu "B" = **0,05 mm**  
 bei einem Abstand von **x = 100 mm**



English	Français	Italiano
<p>13. Set internal dial gauge. Gauge bearing shells at points „1“ and „2“ in planes „a“ and „b“.</p>	<p>13. Régler l'appareil de contrôle. Effectuer le relevé des cotes des coussinets aux points „1“ et „2“ au niveau des plans „a“ et „b“.</p>	<p>13. Registrare il comparatore per interni. Misurare i semicuscinetti di biella nei punti "1" e "2" sui piani "a" e "b".</p>
<p>Big end bearing shells            Inner diameter:            BFM 1012      <b>58.03-58.07 mm</b>            BFM 1013      <b>68.036-68.076 mm</b>            Each undersize      <b>0.25 mm</b></p>	<p>Coussinets de bielle diamètre intérieur            BFM 1012      <b>58,03 - 58,07 mm</b>            BFM 1013      <b>68,036 - 68,076 mm</b>            Cote de rectification respective      <b>0,25 mm</b></p>	<p>Semicuscinetto di biella            Diametro interno:            BFM 1012      <b>58,03 - 58,07 mm</b>            BFM 1013      <b>68,036 - 68,076 mm</b>            Grado di minorazione      <b>0,25 mm</b></p>
<p>Limit for undersize:            BFM 1012      <b>57.78-57.82 mm</b>            BFM 1013      <b>67.536-67.576 mm</b></p>	<p>Cote limite pour cote de rectification            BFM 1012      <b>57,78 - 57,82 mm</b>            BFM 1013      <b>67,536 - 67,576 mm</b></p>	<p>Misura limite per grado di minorazione:            BF 1012      <b>57,78 - 57,82 mm</b>            BF 1013      <b>67,536 - 67,576 mm</b></p>
<p>Wear limit:            Clearance of big end bearing <b>0.12 mm</b></p>	<p>Limite d'usure :            Jeu au coussinets de bielle <b>0,12 mm</b></p>	<p>Limite di usura:            gioco del cuscinetto di biella <b>0,12 mm</b></p>
<p><b>Note:</b> If the readings do not exceed bearing tolerances by more than <b>0.015 mm</b>, the rod can be used further. If the limit value is exceeded, replace the connecting rod.</p>	<p><b>Nota:</b> si les valeurs dépassent au maximum de <b>0,015 mm</b> les tolérances du coussinet, la bielle peut rester en service. Dans le cas contraire, la remplacer.</p>	<p><b>Nota:</b> Se i valori misurati risultano al massimo di <b>0,015 mm</b> al di sopra delle tolleranze del cuscinetto, la biella può venire ulteriormente utilizzata. Se tale valore viene superato, la biella deve venire sostituita.</p>
<p>14. Check connecting rod without bearing shells on connecting rod tester.</p>	<p>14. Contrôler toute bielle sans coussinet sur un appareil de contrôle notamment</p>	<p>14. Controllare sull'apposito apparecchio di controllo. la biella senza i semicuscinetti.</p>
<p>14.1 Parallelism check:             Permissible tolerance <math>a = 0.05 \text{ mm}</math> over a distance of <math>x = 100 \text{ mm}</math></p>	<p>14.1 au niveau du parallélisme             Ecart admissible <math>a = 0,05 \text{ mm}</math> pour une distance de <math>x = 100 \text{ mm}</math></p>	<p>14.1 Controllo del parallelismo:             scarto ammesso "a" = <b>0,05 mm</b> su una distanza "x" = <b>100 mm</b></p>
<p>14.2 Squareness check:             Permissible tolerance „A“ relative to „B“ = <b>0.05 mm</b> over a distance of <math>x = 100 \text{ mm}</math></p>	<p>14.2 ainsi que de l'équerrage             Ecart admissible „A“ par rapport „B“ = <b>0,05 mm</b> pour une distance de <math>x = 100 \text{ mm}</math></p>	<p>14.2 Controllo dell'angolarità:             scarto ammesso "A" rispetto a "B" = <b>0,05 mm</b> su una distanza "x" = <b>100 mm</b></p>



English	Français	Italiano
<b>Assembling connecting rod with piston</b>	<b>Compléter l'ensemble bielle-piston</b>	<b>Assemblaggio biella pistone</b>
15. Bring one circlip into correct position and fit. <b>See note.</b>	15. Ajuster et placer un circlip. <b>Voir nota.</b>	15. Disporre correttamente l'anello di sicurezza ed inserirlo nella sua sede <b>Vedi nota.</b>
BFM 1012 piston	Piston BFM 1012	Pistone BFM 1012
BFM 1013 piston	Piston BFM 1013	Pistone BFM 1013
<b>Note:</b> Ring gaps of circlips must face towards piston crown.	<b>Nota:</b> les coupes des circlips doivent être orientées vers la tête du piston.	<b>Nota:</b> Le estremità degli anelli di sicurezza devono essere rivolte verso il cielo del pistone.
16. Install piston together with connecting rod. Flywheel symbol on the piston and dowel pins of the connecting rod must be located on the same side.	16. Monter l'ensemble piston-bielle. Le symbole du volant moteur figurant sur le piston et les pions de positionnement de la bielle doivent être orientés du même côté.	16. Montare la biella col pistone. Il simbolo del volante sul pistone e le spine calibrate della biella devono trovarsi sullo stesso lato.

Deutsch

Werkstatthandbuch BFM 1012/E, BFM 1013/E

Pleuelstange mit Kolben komplettieren

15. Einen Sicherungsring ausrichten und einsetzen.  
**Siehe Hinweis.**

Kolben BFM 1012



Kolben BFM 1013



**Hinweis:** Ringstöße der Sicherungsringe müssen zum Kolbenboden zeigen.

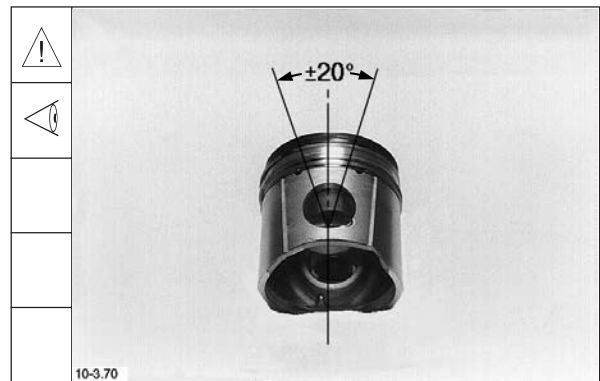

16. Kolben mit der Pleuelstange montieren.  
Das Schwungradsymbol auf dem Kolben und die Paßstifte der Pleuelstange müssen auf der gleichen Seite sein.

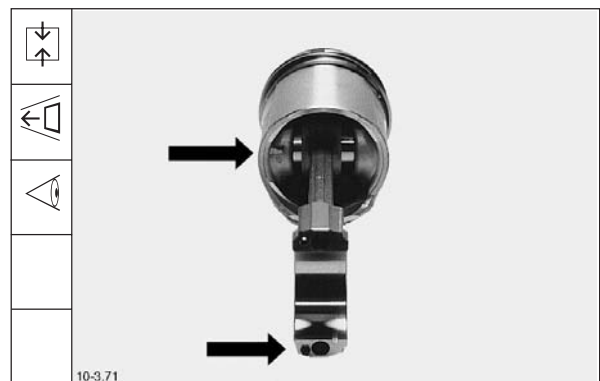

Werkstatthandbuch BFM 1012/E, BFM 1013/E



Deutsch

17. Zweiten Sicherungsring ausrichten und einsetzen.

Kolben BFM 1012

Kolben BFM 1013

<b>English</b>	<b>Français</b>	<b>Italiano</b>
17. Bring second circlip into correct position and fit.	17. Placer et ajuster un deuxième circlip.	17. Disporre correttamente il secondo anello di sicurezza ed inserirlo nella sua sede.
BFM 1012 piston	Piston BFM 1012	Pistone BFM 1012
BFM 1013 piston	Piston BFM 1013	Pistone BFM 1013

**Bauteile instand setzen**  
**Repair of components**  
**Mise en état des composants**  
**Riparazione dei componenti**

---

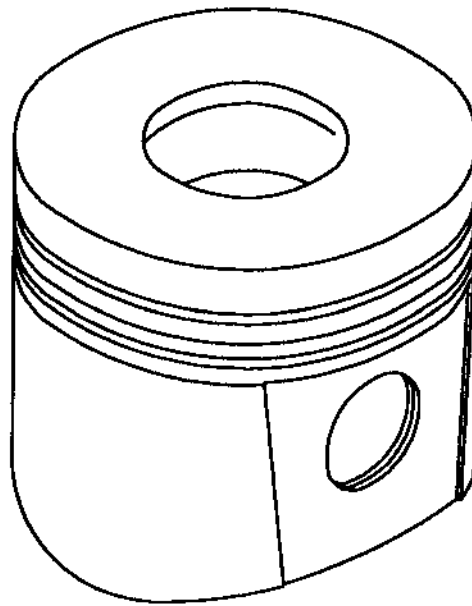

English	Français	Italiano
<p><b>Special tools required:</b></p> <p>Piston ring pliers: _____ 130 300 Disassembly tool for piston pin circlip BFM 1012_ 131 080</p>	<p><b>Outillage spécial :</b></p> <p>Pince à monter les segments de piston _____ 130 300 Outil de démontage de frein d'axe de piston BFM 1012 _____ 131 080</p>	<p><b>Attrezzi speciali:</b></p> <p>Pinza speciale per il montaggio delle fasce elastiche _____ 130 300 Attrezzo per lo smontaggio dell'arresto dello spinotto __ 131 080</p>
<p><b>BFM 1012</b></p> <p>1. Remove circlip with auxiliary tool. Take out piston pin.</p> <p><b>Note:</b> Risk of injury when not using auxiliary tool.</p>	<p><b>BFM 1012</b></p> <p>1. Utiliser l'outil auxiliaire pour enlever le circlip. Retirer l'axe du piston.</p> <p><b>Nota:</b> attention! Pour éviter tout risque de blessure toujours utiliser l'outil auxiliaire.</p>	<p><b>BFM 1012</b></p> <p>1. Servendosi dell'apposito attrezzo, smontare l'anello di sicurezza. Estrarre lo spinotto.</p> <p><b>Nota:</b> Se non si usa l'apposito attrezzo si rischia di ferirsi.</p>
<p><b>BFM 1013</b></p> <p>1.1 Remove circlip. Take out piston pin.</p> <p>2. Adjust piston ring pliers to piston diameter. Remove piston rings.</p>	<p><b>BFM 1013</b></p> <p>1.1 Oter le circlip. Retirer l'axe de piston.</p> <p>2. Régler la pince à monter les segments sur le diamètre du piston. Déposer les segments.</p>	<p><b>BFM 1013</b></p> <p>1.1 Smontare l'anello di sicurezza. Estrarre lo spinotto.</p> <p>2. Aggiustare la pinza speciale in base al diametro del pistone. Smontare le fasce elastiche.</p>



Deutsch

Werkstatthandbuch BFM 1012/E, BFM 1013/E

Spezialwerkzeuge:

Kolbenring-Auflegezange: \_\_\_\_\_ 130 300  
Demontagewerkzeug für  
Kolbenbolzensicherung BFM 1012 \_\_ 131 080

**BFM 1012**

1. Sicherungsring mit Hilfswerkzeug entfernen. Kolbenbolzen herausnehmen.

**Hinweis:** Ohne Hilfswerkzeug besteht Verletzungsgefahr.



**BFM 1013**

- 1.1 Sicherungsring entfernen. Kolbenbolzen herausnehmen.



2. Kolbenring-Auflegezange auf den Kolbendurchmesser einstellen. Kolbenringe abbauen.

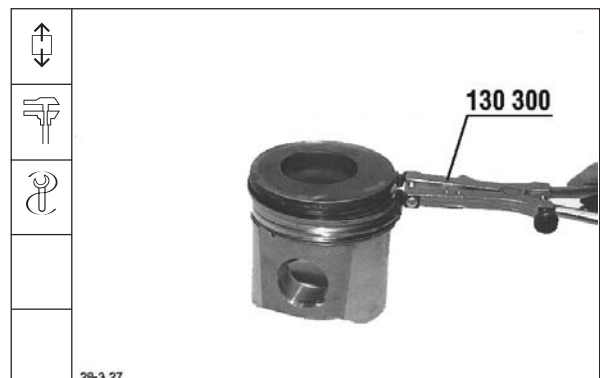

Werkstatthandbuch BFM 1012/E, BFM 1013/E

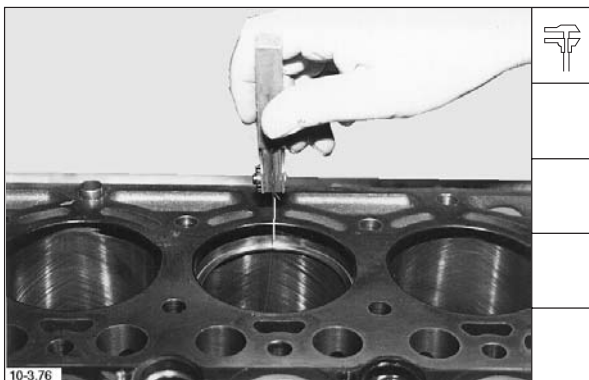

3

Deutsch

3. Kolben und Ringnuten reinigen und sichtprüfen.

4. Kolbenringstoßspiel mit Fühlerlehre messen.

Verschleißgrenzen BFM 1012:

Stoßspiel 1. Ring	<b>0,8 mm</b>
Stoßspiel 2. Ring	<b>2,5 mm</b>
Stoßspiel 3. Ring	<b>1,15 mm</b>

Verschleißgrenzen BFM 1013:

Stoßspiel 1. Ring	<b>0,8 mm</b>
Stoßspiel 2. Ring	<b>2,5 mm</b>
Stoßspiel 3. Ring	<b>1,15 mm</b>

5. Kolbenringnuten mit Fühlerlehre messen.

**Hinweis:** Messung mit neuen Kolbenringen durchführen.

Verschleißgrenzen:

Axialspiel 1. Ring	<b>Doppeltrapeznut</b>
Axialspiel 2. Ring	<b>0,17 mm</b>
Axialspiel 3. Ring	<b>0,10 mm</b>

6. Kolbenbolzen auf Verschleiß prüfen.

Kolbenbolzendurchmesser:

BFM 1012	<b>34 - 0,006 mm</b>
BFM 1013	<b>42 - 0,006 mm</b>

English	Français	Italiano
<p>3. Clean and inspect piston and ring grooves.</p>	<p>3. Nettoyer le piston et les gorges annulaires puis les contrôler visuellement.</p>	<p>3. Pulire il pistone e le sedi delle fasce elastiche ed effettuare un controllo visivo.</p>
<p>4. Measure ring gap with feeler gauge.</p> <p>Wear limits BFM 1012: 1st ring gap           <b>0.8 mm</b> 2nd ring gap           <b>2,5 mm</b> 3rd ring gap           <b>1.15 mm</b></p> <p>Wear limits BFM 1013: 1st ring gap           <b>0.8 mm</b> 2nd ring gap           <b>2.5 mm</b> 3rd ring gap           <b>1.15 mm</b></p>	<p>4. Mesurer le jeu à la coupe avec une jauge d'épaisseur.</p> <p>Limites d'usure BFM 1012: Jeu à la coupe 1er segment           <b>0,8 mm</b> 2ème segment       <b>2,5 mm</b> 3ème segment       <b>1,15 mm</b></p> <p>Limites d'usure BFM 1013: eu à la coupe 1er segment           <b>0,8 mm</b> 2ème segment       <b>2,5 mm</b> 3ème segment       <b>1,15 mm</b></p>	<p>4. Servendosi di uno spessimetro, misurare la luce tra le estremità delle fasce elastiche.</p> <p>Limiti d'usura BFM 1012: Luce della I fascia   <b>0,8 mm</b> Luce della II fascia   <b>2,5 mm</b> Luce della III fascia   <b>1,15 mm</b></p> <p>Limiti d'usura BFM 1013: Luce della I fascia   <b>0,8 mm</b> Luce della II fascia   <b>2,5 mm</b> Luce della III fascia   <b>1,15 mm</b></p>
<p>5. Measure ring grooves with feeler gauge.</p> <p><b>Note:</b> Measurement to be made with new piston rings.</p> <p>Wear limits: axial play 1st ring <b>keystone groove</b></p> <p>axial play 2nd ring   <b>0.17 mm</b> axial play 3rd ring   <b>0.10 mm</b></p>	<p>5. Relever les cotes des gorges de segments avec une jauge d'épaisseur.</p> <p><b>Nota:</b> Effectuer les mesures avec des segments neufs.</p> <p>Limites d'usure : Jeu axial 1er segment <b>trapézoïdal double</b></p> <p>2ème segment       <b>0,17 mm</b> 3ème segment       <b>0,10 mm</b></p>	<p>5. Servendosi di uno spessimetro, misurare l'altezza delle sedi delle fasce elastiche.</p> <p><b>Nota:</b> Misurazione da effettuarsi con fasce elastiche nuove</p> <p>Limiti d'usura: Gioco assiale I fascia   <b>Profilo a doppio trapezio</b></p> <p>Gioco assiale II fascia   <b>0,17 mm</b> Gioco assiale III fascia   <b>0,10 mm</b></p>
<p>6. Check piston pin for wear.</p> <p>Piston pin diameter: BFM 1012           <b>34 - 0.006 mm</b> BFM 1013           <b>42 - 0.006 mm</b></p>	<p>6. Contrôler l'usure de l'axe du piston.</p> <p>Diamètre de l'axe du piston: BFM 1012           <b>34 - 0,006 mm</b> BFM 1013           <b>42 - 0,006 mm</b></p>	<p>6. Verificare l'usura dello spinotto.</p> <p>Diametro dello spinotto: BFM 1012           <b>34 - 0,006 mm</b> BFM 1013           <b>42 - 0,006 mm</b></p>



English	Français	Italiano
<p>7. Order and position of piston rings:</p> <ol style="list-style-type: none"><li>1. keystone ring, top facing combustion chamber</li><li>2. tapered compression ring, top facing combustion chamber</li><li>3. bevelled-edge slotted oil control ring</li></ol> <p>8. Fit piston rings.</p> <p><b>Note:</b> Spring gap of bevelled-edge ring to be offset by <b>180°</b> relative to ring gap.</p>	<p>7. Ordre et position des segments:</p> <ol style="list-style-type: none"><li>1. segment trapézoïdal double</li><li>2. segment biseauté top orienté vers chambre de combustion</li><li>3. segment racleur à double chanfrein</li></ol> <p>8. Monter les segments de piston.</p> <p><b>Nota:</b> décaler la coupe du ressort du segment racleur de <b>180°</b> par rapport à la coupe de segment.</p>	<p>7. Successione e posizione delle fasce elastiche.</p> <ol style="list-style-type: none"><li>1. Fascia a doppio trapezio, Top rivolto verso la camera di combustione.</li><li>2. Fascia a smusso, Top rivolto verso la camera di combustione.</li><li>3. Fascia raschia-olio</li></ol> <p>8. Montare le fasce elastiche.</p> <p><b>Nota:</b> Sfasare di 180° la giuntura della molla rispetto alla giuntura dell'anello raschia-olio.</p>

Deutsch

Werkstatthandbuch BFM 1012/E, BFM 1013/E

7. Reihenfolge und Lage der Kolbenringe:

1. Doppeltrapezring, Top zum Brennraum weisend
2. Minutenring, Top zum Brennraum weisend
3. Ölschlitz-Dachfasenring

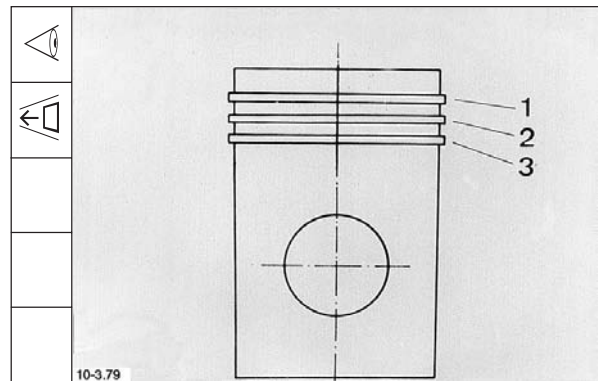

8. Kolbenringe montieren.

**Hinweis:** Federstoß des Dachfasenringes um **180°** zum Ringstoß versetzen.

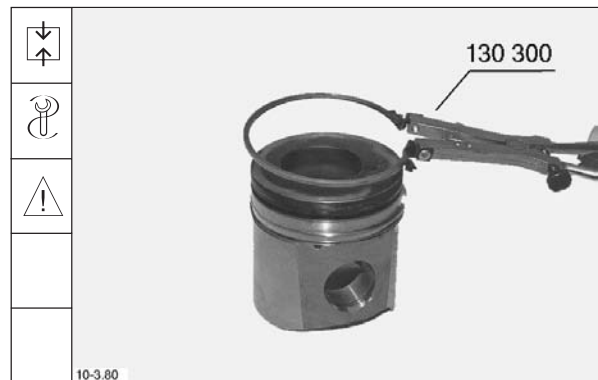

**Bauteile instand setzen**  
**Repair of components**  
**Mise en état des composants**  
**Riparazione dei componenti**

---

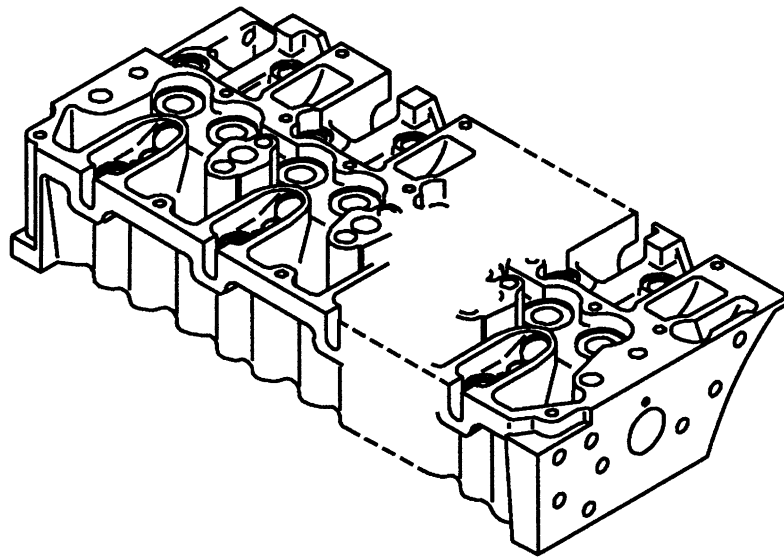

English	Français	Italiano
<p><b>Commercial tools required:</b></p> <p>Magnetic measuring stand Valve spring assembly lever _____ 9017 Valve reseating tool</p>	<p><b>Outillage usuel:</b></p> <p>Support magnétique Lever de montage pour ressorts de soupape _____ 9017 Appareil d'usinage pour sièges de soupape</p>	<p><b>Attrezzi comuni:</b></p> <p>Supporto magnetico per le misurazioni Leva per il montaggio delle molle delle valvole _____ 9017 Attrezzo per la rettifica delle sedi delle valvole</p>
<p><b>Special tools required:</b></p> <p>Clamping stand _____ 120 900 Clamping plate _____ 120 910</p>	<p><b>Outillage spécial:</b></p> <p>Chevalet d'ablocage _____ 120 900 Plaque d'ablocage _____ 120 910</p>	<p><b>Attrezzi speciali:</b></p> <p>Cavalletto di fissaggio _____ 120 900 Piastra di fissaggio _____ 120 910</p>
<p>1. Mount cylinder head on fixture.</p> <p>2. Unscrew blanking parts or pencil-type glow plugs if any.</p>	<p>1. Monter la culasse dans le dispositif.</p> <p>2. Dévisser puis retirer les éléments de fermeture ou les bougies de préchauffage si le moteur en est équipé.</p>	<p>1. Fissare la testa cilindri all'attrezzo.</p> <p>2. Smontare le candele di preriscaldamento, qualora presenti, oppure i tappi filettati.</p>



Deutsch

Werkstatthandbuch BFM 1012/E, BFM 1013/E

Handelsübliche Werkzeuge:

Magnet-Meßstativ  
Ventilfedermontagehebel \_\_\_\_\_ 9017  
Ventilsitzbearbeitungsgerät

Spezialwerkzeuge:

Aufspannbock \_\_\_\_\_ 120 900  
Aufspannplatte \_\_\_\_\_ 120 910

1. Zylinderkopf an Vorrichtung anbauen.

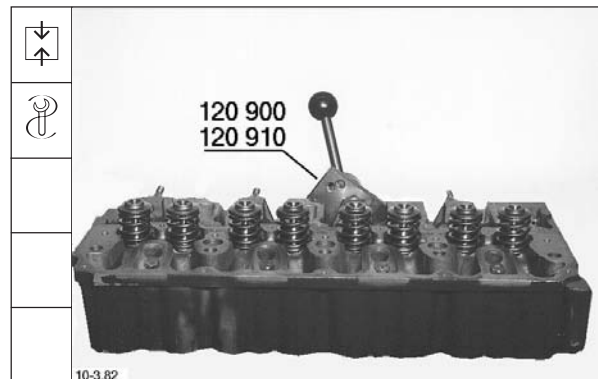

2. Verschußteile oder falls vorhanden Glühstiftkerzen herauschrauben.

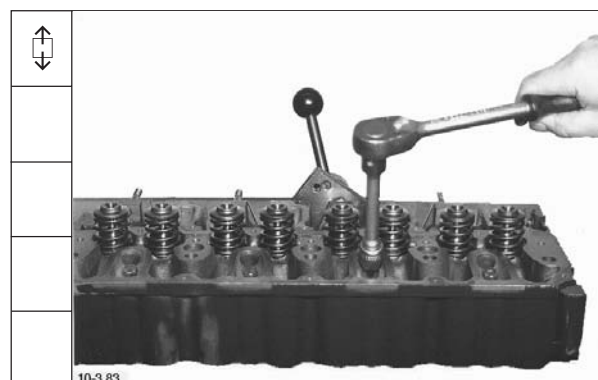

Werkstatthandbuch BFM 1012/E, BFM 1013/E

Deutsch

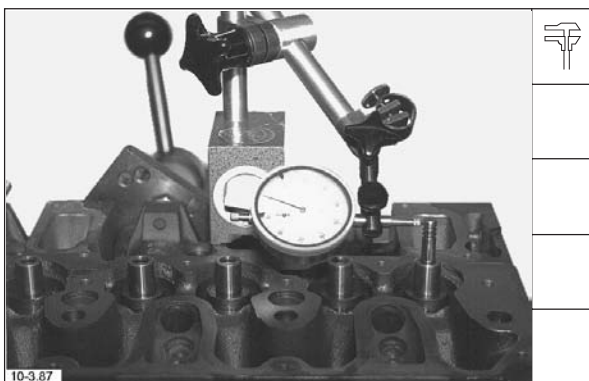
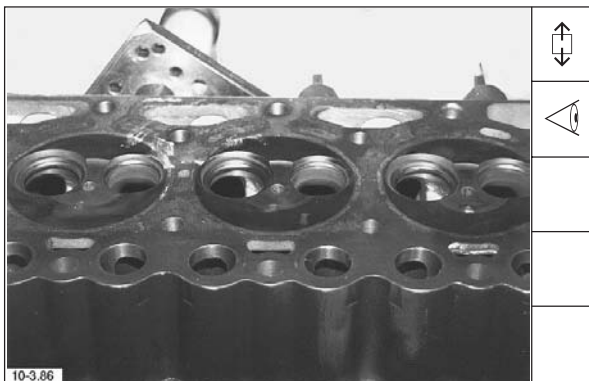
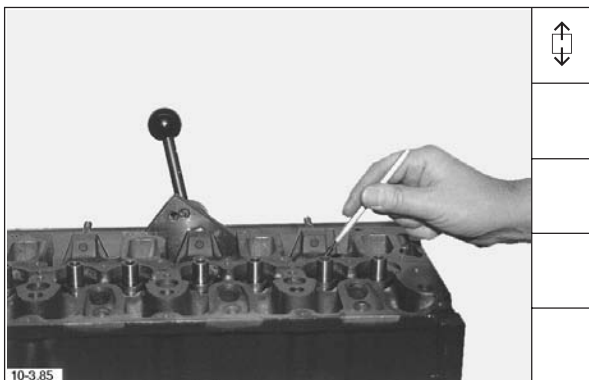
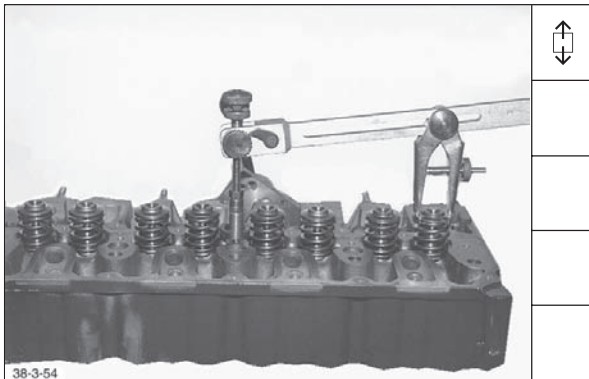

3. Klemmkegel, Ventildfederteller, Ventildfedern und Ventile ausbauen.

4. Ventilschaftabdichtung herausnehmen.

5. Zylinderkopf reinigen und auf Beschädigung sichtprüfen.

6. Ventilschaftspiel messen.

Verschleißgrenzen:

Einlaßventil	<b>0,10 mm</b>
Auslaßventil	<b>0,13 mm</b>

English	Français	Italiano
3. Remove cone clamp, valve spring cap, valve springs and valves.	3. Déposer clavettes, coupelles, ressorts de soupape et soupapes.	3. Smontare i semiconi, i piattelli delle molle, le molle e le valvole.
4. Remove valve stem seal.	4. Déposer le joint de tige de soupape.	4. Smontare la tenuta dello stelo della valvola.
5. Clean cylinder head and inspect for damage.	5. Nettoyer la culasse et vérifier si elle n'est pas endommagée.	5. Pulire la testa cilindri e controllare che non sia danneggiata.
6. Gauge valve stem clearance.	6. Relever le jeu à la tige de soupape.	6. Misurare il gioco dello stelo delle valvole
Wear limits:	Limites d'usure :	Limiti d'usura:
Inlet valve <b>0.10 mm</b> Exhaust valve <b>0.13 mm</b>	Soupape ADM <b>0,10 mm</b> Soupape ECH <b>0,13 mm</b>	Valvola d'aspirazione <b>0,10 mm</b> Valvola di scarico <b>0,13 mm</b>



English	Français	Italiano
7. Inspect valves and gauge them.  Valve stem diameter: standard  Inlet valve BFM 1012 <b>7.98 - 0.015 mm</b> BFM 1013 <b>8.98 - 0.015 mm</b>  Exhaust valve BFM 1012 <b>7.96 - 0.015 mm</b> BFM 1013 <b>8.96 - 0.015 mm</b>	7. Contrôler visuellement les soupapes et faire un relevé des cotes.  Diamètre de la tige de soupape valeur normale Soupape ADM BFM 1012 <b>7,98 - 0,015 mm</b> BFM 1013 <b>8,98 - 0,015 mm</b> Soupape ECH BFM 1012 <b>7,96 - 0,015 mm</b> BFM 1013 <b>8,96 - 0,015 mm</b>	7. Controllare le valvole e misurarle.  Diametro normale dello stelo della valvola: Valvola aspirazione BFM 1012 <b>7,98 - 0,015 mm</b> BFM 1013 <b>8,98 - 0,015 mm</b> Valvola scarico BFM 1012 <b>7,96 - 0,015 mm</b> BFM 1013 <b>8,96 - 0,015 mm</b>
7.1 Valve rim thickness  Wear limits: Inlet valve BFM 1012 <b>1.8 mm</b> BFM 1013 <b>2.1 mm</b> Exhaust valve BFM 1012 <b>1.1 mm</b> BFM 1013 <b>1.8 mm</b>	7.1 Epaisseur du bord de soupape  Limites d'usure : Soupape ADM BFM 1012 <b>1,8 mm</b> BFM 1013 <b>2,1 mm</b> Soupape ECH BFM 1012 <b>1,1 mm</b> BFM 1013 <b>1,8 mm</b>	7.1 Spessore del bordo di tenuta:  Limiti d'usura: Valvola aspirazione BFM 1012 <b>1,8 mm</b> BFM 1013 <b>2,1 mm</b> Valvola scarico BFM 1012 <b>1,1 mm</b> BFM 1013 <b>1,8 mm</b>
7.2 Valve disc diameter  Inlet valve BFM 1012 <b>41.7 ± 0.1 mm</b> BFM 1013 <b>48.0 ± 0.1 mm</b>  Exhaust valve BFM 1012 <b>35.9 ± 0.1 mm</b> BFM 1013 <b>42.0 ± 0.1 mm</b>	7.2 Diamètre de tête de soupape  Soupape ADM BFM 1012 <b>41,7 ± 0,1 mm</b> BFM 1013 <b>48,0 ± 0,1 mm</b>  Soupape ECH BFM 1012 <b>35,9 ± 0,1 mm</b> BFM 1013 <b>42,0 ± 0,1 mm</b>	7.2 Diametro della testa:  Valvola aspirazione BFM 1012 <b>41,7 ± 0,1 mm</b> BFM 1013 <b>48,0 ± 0,1 mm</b>  Valvola scarico BFM 1012 <b>35,9 ± 0,1 mm</b> BFM 1013 <b>42,0 ± 0,1 mm</b>
8. Inspect valve seat inserts and check wear tolerances.  Wear limit of valve, seat width:  Inlet valve BFM 1012 <b>2.7 mm</b> BFM 1013 <b>2.8 mm</b> Exhaust valve BFM 1012 <b>2.1 mm</b> BFM 1013 <b>2.2 mm</b>	8. Contrôle visuel des sièges rapportés. Vérifier les cotes d'usure.  Largeur du siège, limite d'usure :  Soupape ADM BFM 1012 <b>2,7 mm</b> BFM 1013 <b>2,8 mm</b> Soupape ECH BFM 1012 <b>2,1 mm</b> BFM 1013 <b>2,2 mm</b>	8. Controllare le sedi delle valvole. Verificare i limiti d'usura.  Valvola aspirazione BFM 1012 <b>2,7 mm</b> BFM 1013 <b>2,8 mm</b> Valvola scarico BFM 1012 <b>2,1 mm</b> BFM 1013 <b>2,2 mm</b>

**Deutsch**

**Werkstatthandbuch BFM 1012/E, BFM 1013/E**

7. Ventile sichtprüfen und vermessen.

Ventilschaftdurchmesser: normal

Einlaßventil

BFM 1012	<b>7,98 - 0,015 mm</b>
BFM 1013	<b>8,98 - 0,015 mm</b>

Auslaßventil

BFM 1012	<b>7,96 - 0,015 mm</b>
BFM 1013	<b>8,96 - 0,015 mm</b>

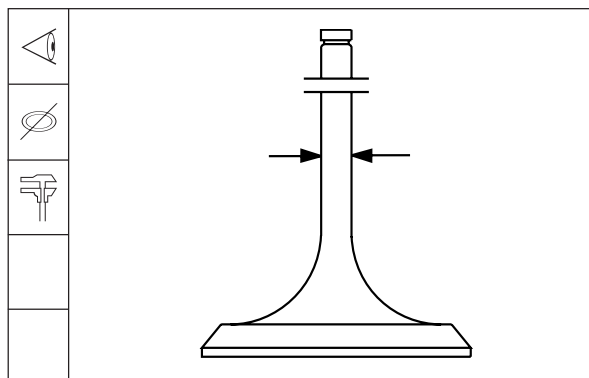

7.1 Ventilrandstärke

Verschleißgrenzen :

Einlaßventil

BFM 1012	<b>1,8 mm</b>
BFM 1013	<b>2,1 mm</b>

Auslaßventil

BFM 1012	<b>1,1 mm</b>
BFM 1013	<b>1,8 mm</b>

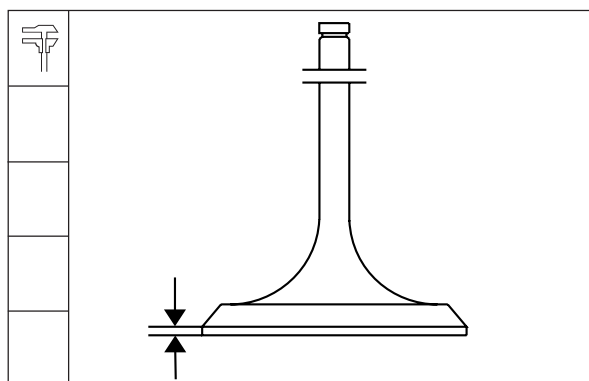

7.2 Ventiltellerdurchmesser:

Einlaßventil

BFM 1012	<b>41,7 ± 0,1 mm</b>
BFM 1013	<b>48,0 ± 0,1 mm</b>

Auslaßventil

BFM 1012	<b>35,9 ± 0,1 mm</b>
BFM 1013	<b>42,0 ± 0,1 mm</b>

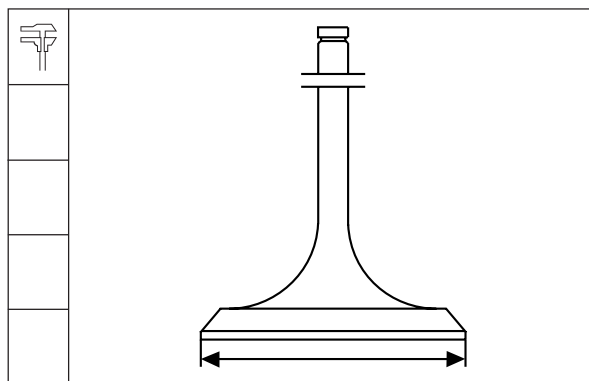

8. Ventilsitzringe sichtprüfen. Verschleißmaße kontrollieren.

Ventilsitzbreite, Verschleißgrenze :

Einlaßventil

BFM 1012	<b>2,7 mm</b>
BFM 1013	<b>2,8 mm</b>

Auslaßventil

BFM 1012	<b>2,1 mm</b>
BFM 1013	<b>2,2 mm</b>

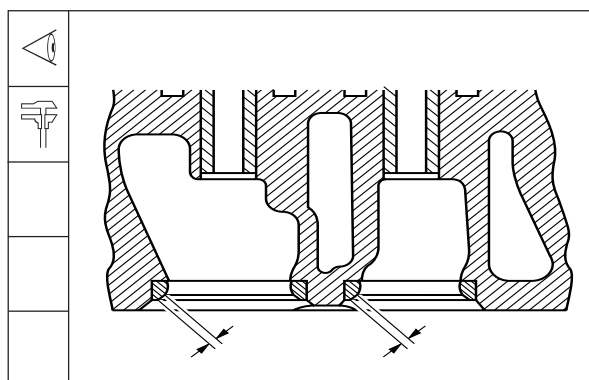

Werkstatthandbuch BFM 1012/E, BFM 1013/E

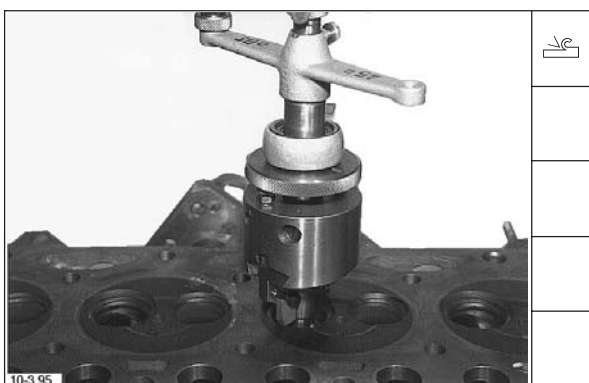
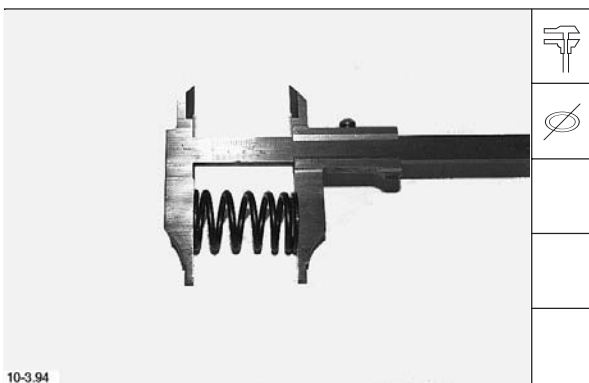
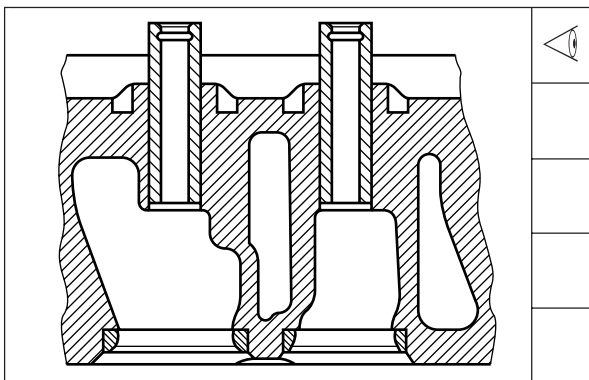
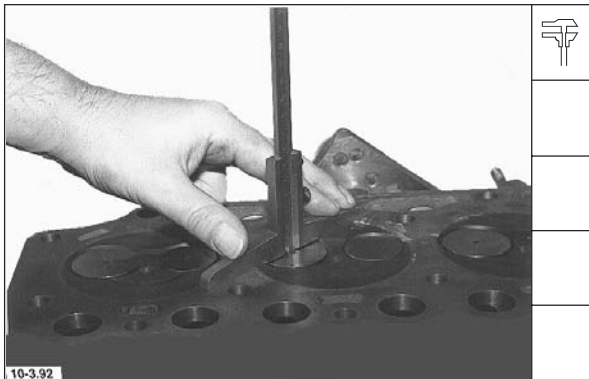

Deutsch

9. Ventilrückstand von der Mitte Ventilteller zur Zylinderkopfdichtfläche messen.

Ventilrückstehmaß

Verschleißgrenze:

BFM 1012	<b>1,4 mm</b>
BFM 1013	<b>1,5 mm</b>

10. Bei verschlissenen Ventilsitzringen, Ventilführungen oder beschädigter Zylinderkopfdichtfläche besteht die Möglichkeit, den Zylinderkopf in unseren Service-Centern instandsetzen zu lassen.

11. Länge der Ventilsfeder messen.

Länge ungespannt, normal

BFM 1012	<b>59 ± 1,9 mm</b>	
BFM 1013	<b>64,7 ± 1,3 mm</b>	<b>n = 2300</b>
BFM 1013	<b>66,2 mm</b>	<b>n = 2600</b>

12. Korrekturen am Ventilsitz mit Ventilsitz-Bearbeitungsgerät durchführen.

English	Français	Italiano
<p>9. Gauge valve clearance between valve disc center and cylinder head sealing surface.</p> <p>Valve penetration into cylinder head</p> <p>Wear limit:            BFM 1012           <b>1.4 mm</b>            BFM 1013           <b>1.5 mm</b></p>	<p>9. Relever le retrait de soupape du centre de la tête de soupape jusqu'au plan de joint de culasse.</p> <p>Cote de retrait de soupape</p> <p>Limite d'usure:            BFM 1012           <b>1,4 mm</b>            BFM 1013           <b>1,5 mm</b></p>	<p>9. Misurare di quanto rientra il centro della testa delle valvole rispetto alla superficie di appoggio della testa cilindri:            Rientranza della valvola</p> <p>Limite d'usura:            BFM 1012           <b>1,4 mm</b>            BFM 1013           <b>1,5 mm</b></p>
<p>10. If valve seat inserts, valve guides are worn out or cylinder head sealing surface is damaged, it is possible to have the cylinder head repaired in our service centers.</p>	<p>10. Quand les sièges de soupape ou les guides de soupape sont usés et que le plan d'appui de culasse est endommagé, il est possible de remettre en état la culasse dans l'un de nos points de service après-vente.</p>	<p>10. Se le sedi riportate o le guide delle valvole sono usurate, oppure la superficie di appoggio della testa cilindri è danneggiata, esiste la possibilità di far riparare la testa cilindri nei nostri centri di servizio.</p>
<p>11. Gauge length of valve spring.</p> <p>Unloaded length, standard</p> <p>BFM 1012   <b>59 ± 1.9 mm</b>            BFM 1013   <b>64.7 ± 1.3 mm   n = 2300</b>            BFM 1013           <b>66.2 mm   n = 2600</b></p>	<p>11. Relever les cotes de longueur du ressort de soupape.</p> <p>Longueur normale non tendue</p> <p>BFM 1012   <b>59 ± 1,9 mm</b>            BFM 1013   <b>64,7 ± 1,3 mm   n = 2300</b>            BFM 1013           <b>66,2 mm   n = 2600</b></p>	<p>11. Misurare la lunghezza delle molle delle valvole.</p> <p>Lunghezza normale della molla scarica:</p> <p>BFM 1012   <b>59 ± 1,9 mm</b>            BFM 1013   <b>64,7 ± 1,3 mm   n = 2300</b>            BFM 1013           <b>66,2 mm   n = 2600</b></p>
<p>12. Correct valve seat using valve reseating tool.</p>	<p>12. Effectuer les corrections au niveau de la largeur de portée en utilisant un appareil d'usinage de siège de soupape.</p>	<p>12. Rettificare le sedi delle valvole facendo uso dell'apposito attrezzo.</p>



English	Français	Italiano																																													
<p>13. Reworking valve seat insert</p> <table border="0"> <tr> <td>Valve seat angle</td> <td>Inlet</td> <td>Exhaust</td> </tr> <tr> <td></td> <td>30°</td> <td>45°</td> </tr> </table> <table border="0"> <tr> <td>Valve seat width max.</td> <td></td> <td></td> </tr> <tr> <td>BFM 1012</td> <td>2.7 mm</td> <td>2.1 mm</td> </tr> <tr> <td>BFM 1012</td> <td>2.8 mm</td> <td>2.2 mm</td> </tr> </table> <p><b>Note:</b> Measure valve penetration into cylinder head once again after reworking of valve seat insert.</p>	Valve seat angle	Inlet	Exhaust		30°	45°	Valve seat width max.			BFM 1012	2.7 mm	2.1 mm	BFM 1012	2.8 mm	2.2 mm	<p>13. Usinage du siège de soupape</p> <table border="0"> <tr> <td>Angle du siège de soupape</td> <td>ADM</td> <td>ECH</td> </tr> <tr> <td></td> <td>30°</td> <td>45°</td> </tr> </table> <table border="0"> <tr> <td>Largeur de portée du siège de soupape maxi</td> <td></td> <td></td> </tr> <tr> <td>BFM 1012</td> <td>2,7 mm</td> <td>2,1 mm</td> </tr> <tr> <td>BFM 1013</td> <td>2,8 mm</td> <td>2,2 mm</td> </tr> </table> <p><b>Nota:</b> après usinage du siège de soupape faire un nouveau relevé du retrait de soupape.</p>	Angle du siège de soupape	ADM	ECH		30°	45°	Largeur de portée du siège de soupape maxi			BFM 1012	2,7 mm	2,1 mm	BFM 1013	2,8 mm	2,2 mm	<p>13. Rettifica dell'anello di sede della valvola</p> <table border="0"> <tr> <td>Angolo della sede della valvola:</td> <td>aspirazione</td> <td>scarico</td> </tr> <tr> <td></td> <td>30°</td> <td>45°</td> </tr> </table> <table border="0"> <tr> <td>Larghezza max della sede della valvola:</td> <td>aspirazione</td> <td>scarico</td> </tr> <tr> <td>BFM 1012</td> <td>2,7 mm</td> <td>2,1 mm</td> </tr> <tr> <td>BFM 1013</td> <td>2,8 mm</td> <td>2,2 mm</td> </tr> </table> <p><b>Nota:</b> Dopo averne rettificato l'anello di sede, misurare nuovamente la rientranza della valvola.</p>	Angolo della sede della valvola:	aspirazione	scarico		30°	45°	Larghezza max della sede della valvola:	aspirazione	scarico	BFM 1012	2,7 mm	2,1 mm	BFM 1013	2,8 mm	2,2 mm
Valve seat angle	Inlet	Exhaust																																													
	30°	45°																																													
Valve seat width max.																																															
BFM 1012	2.7 mm	2.1 mm																																													
BFM 1012	2.8 mm	2.2 mm																																													
Angle du siège de soupape	ADM	ECH																																													
	30°	45°																																													
Largeur de portée du siège de soupape maxi																																															
BFM 1012	2,7 mm	2,1 mm																																													
BFM 1013	2,8 mm	2,2 mm																																													
Angolo della sede della valvola:	aspirazione	scarico																																													
	30°	45°																																													
Larghezza max della sede della valvola:	aspirazione	scarico																																													
BFM 1012	2,7 mm	2,1 mm																																													
BFM 1013	2,8 mm	2,2 mm																																													
<p>14. Insert valve stem seal.</p>	<p>14. Insérer le joint de queue de soupape.</p>	<p>14. Montare la tenuta dello stelo della valvola.</p>																																													
<p>15. Assemble cylinder head: Position valve spring and valve spring cap.</p> <p><b>Note:</b> Oil valve stem of inlet and exhaust valves, especially in the area of keyseats. Press valves into valve stem guide with a slight turn and applying a slight pressure.</p> <p>With the BFM 1012 engine the narrower coils must face towards cylinder head.</p>	<p>15. Compléter la culasse en montant les ressorts de soupape et les coupelles de ressort.</p> <p><b>Nota:</b> huiler la tige des soupapes d'admission et d'échappement notamment au niveau des rainures de clavette. Insérer dans le guide de soupape les soupapes en tournant et en poussant légèrement.</p> <p>Sur le BFM 1012 les spires les plus étroites doivent être orientées vers la culasse.</p>	<p>15. Assemblaggio della testa cilindri: Montare le molle delle valvole ed i piattelli delle valvole.</p> <p><b>Nota:</b> Oliare il gambo delle valvole di aspirazione e di scarico, specialmente in prossimità delle scanalature. Spingendole leggermente, infilare le valvole nei guidavalvole con movimenti di rotazione.</p> <p>Nel caso del BFM 1012, le spire più strette delle molle delle valvole devono essere rivolte verso la testa cilindri.</p>																																													
<p>16. Fit valve spring assembly lever, insert cone clamp.</p>	<p>16. Mettre en place le levier de montage des ressorts de soupape ainsi que les clavettes demi-cône.</p>	<p>16. Installare la leva per il montaggio delle molle delle valvole ed inserire i semiconi.</p>																																													



Deutsch

Werkstatthandbuch BFM 1012/E, BFM 1013/E

13. Ventilsitzringbearbeitung

Ventilsitzwinkel	Einlaß	Auslaß
	<b>30°</b>	<b>45°</b>
Ventilsitzbreite max.		
BFM 1012	<b>2,7 mm</b>	<b>2,1 mm</b>
BFM 1013	<b>2,8 mm</b>	<b>2,2 mm</b>

**Hinweis:** Nach Ventilsitzringbearbeitung nochmals Ventilrückstand messen.



14. Ventilschaftabdichtung einsetzen.



15. Zylinderkopf komplettieren:  
Ventilfeder und Ventildferteller aufsetzen.

**Hinweis:** Ventilschaft von Ein- und Auslaßventil, besonders im Bereich der Keilnuten, einölen. Ventile mit Drehbewegung unter leichtem Druck in die Ventilschaftführung eindrücken.

Bei BFM 1012 müssen die engeren Windungen der Ventilfedern zum Zylinderkopf weisen.

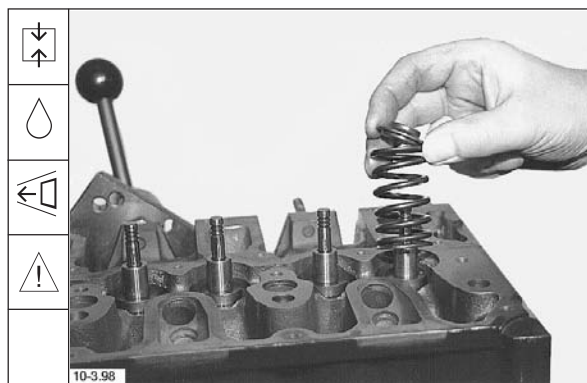

16. Ventildfeder montagehebel aufbauen,  
Klemmkegel einsetzen.

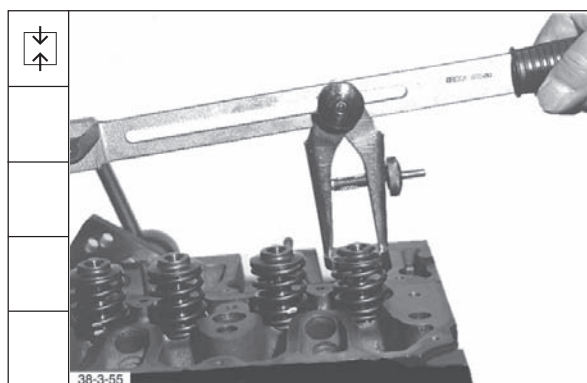

Werkstatthandbuch BFM 1012/E, BFM 1013/E

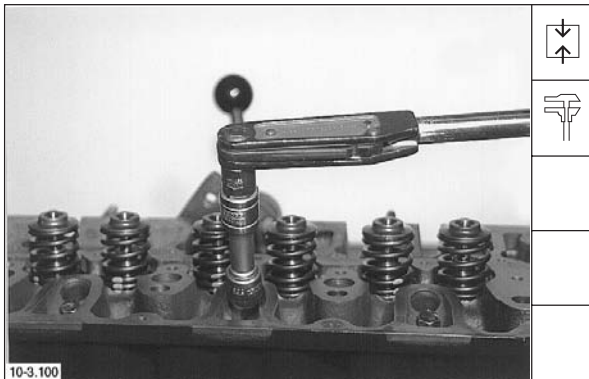

Deutsch

17. Verschluss­teile anbauen und mit einem Drehmoment von **10 + 5 Nm** festdrehen.

English	Français	Italiano
17. Fit blanking parts and tighten with a torque of <b>10 + 5 Nm</b> .	17. Monter les éléments de fermeture et serrer ensuite au couple de <b>10 + 5 Nm</b> .	17. Montare i cappellotti di bloccaggio, serrandoli con <b>10 + 5 Nm</b> .

**Bauteile instand setzen**  
**Repair of components**  
**Mise en état des composants**  
**Riparazione dei componenti**

---

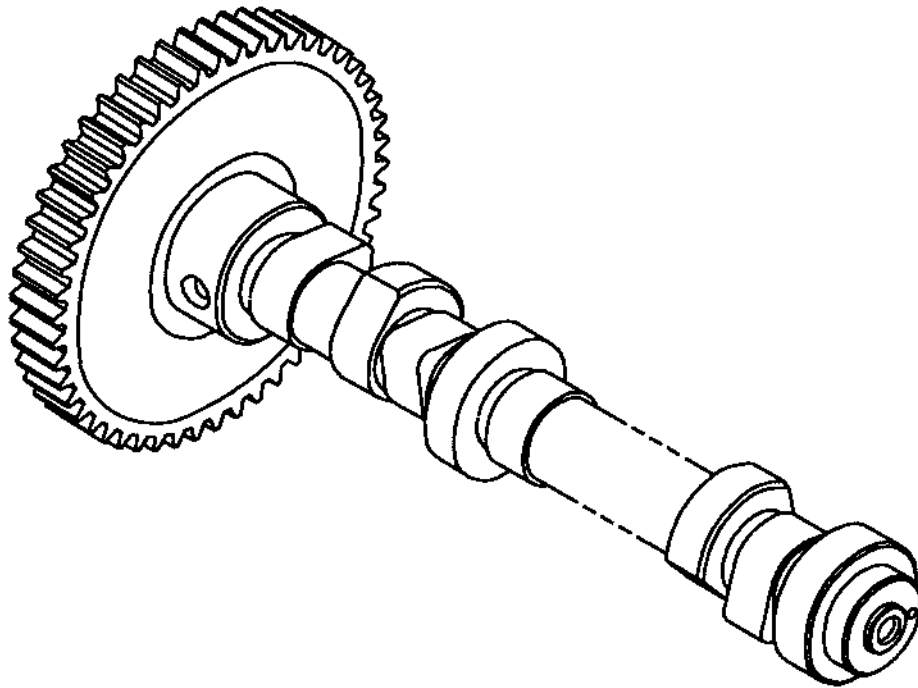

English	Français	Italiano
1. Inspect cams and bearing journals for wear.	1. Contrôle visuellement l'usure des cames et tourillons.	1. Controllare se le camme ed i perni dei cuscinetti presentano tracce di usura.
2. Inspect camshaft gear for wear.	2. Contrôler visuellement l'usure du pignon d'arbre à cames.	2. Controllare se l'ingranaggio dell'albero a camme presenta tracce di usura.

**Deutsch**

**Werkstatthandbuch BFM 1012/E, BFM 1013/E**

1. Nocken und Lagerzapfen auf Verschleiß sichtprüfen.



2. Nockenwellenzahnrad auf Verschleiß sichtprüfen.

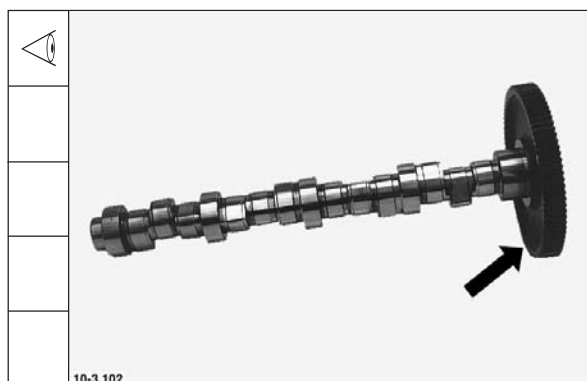

**Bauteile instand setzen**  
**Repair of components**  
**Mise en état des composants**  
**Riparazione dei componenti**

---



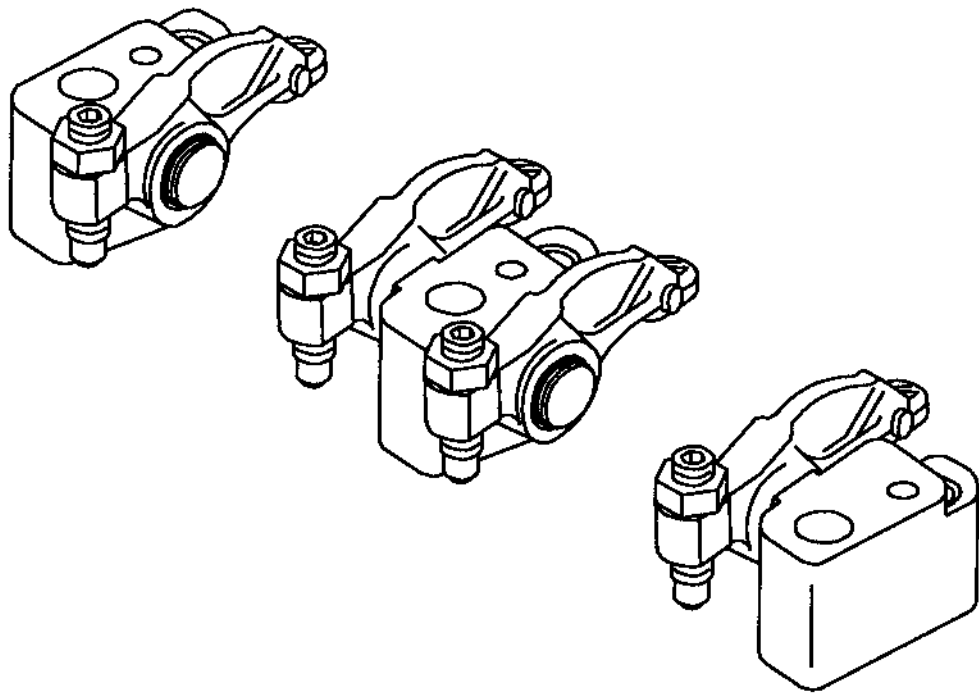

English	Français	Italiano
<p>1. Dismantle rocker arm bracket.</p> <p>2. Check for wear and replace if necessary: - Journals - Adjusting screw, - Rocker arm contact face - Bore</p> <p>3. Check oil duct for free passage.</p> <p>4. Reassemble rocker arm bracket. Fit circlips.</p>	<p>1. Démonter le support de culbuteurs.</p> <p>2. Contrôle de l'usure et au besoin remplacement - des tourillons, - de la vis de réglage, - de la surface de frottement des - culbuteurs et de l'alésage.</p> <p>3. Vérifier le libre passage du conduit de graissage.</p> <p>4. Compléter l'assemblage du support de culbuteurs. Monter les circlips.</p>	<p>1. Scomporre il supporto dei bilancieri</p> <p>2. Controllare l'eventuale usura e qualora necessario sostituire: - Perni dei cuscinetti - Vite di regolazione - Superficie di scorrimento del bilanciere - Foro</p> <p>3. Controllare che il condotto dell'olio sia libero</p> <p>4. Assemblare il supporto dei bilancieri. Montare gli anelli di sicurezza.</p>

**Deutsch**

**Werkstatthandbuch BFM 1012/E, BFM 1013/E**

1. Kipphebelbock zerlegen



2. Auf Verschleiß prüfen ggf. austauschen:  
 - Lagerzapfen  
 - Einstellschraube  
 - Kipphebelgleitfläche  
 - Bohrung

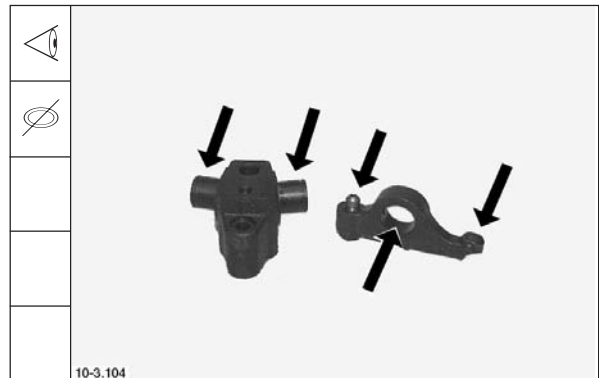

3. Ölkanal auf Durchgang prüfen.

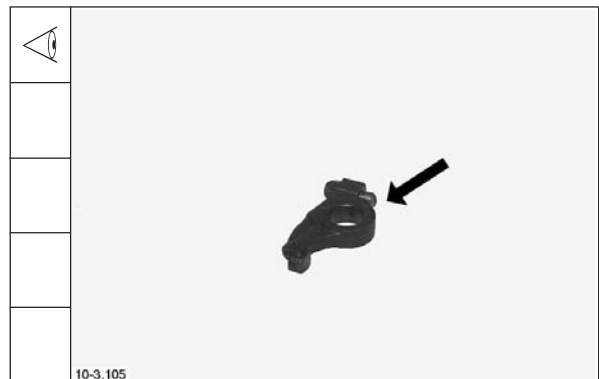

4. Kipphebelbock komplettieren.  
 Sicherungsringe montieren.



**Bauteile instand setzen**  
**Repair of components**  
**Mise en état des composants**  
**Riparazione dei componenti**

---

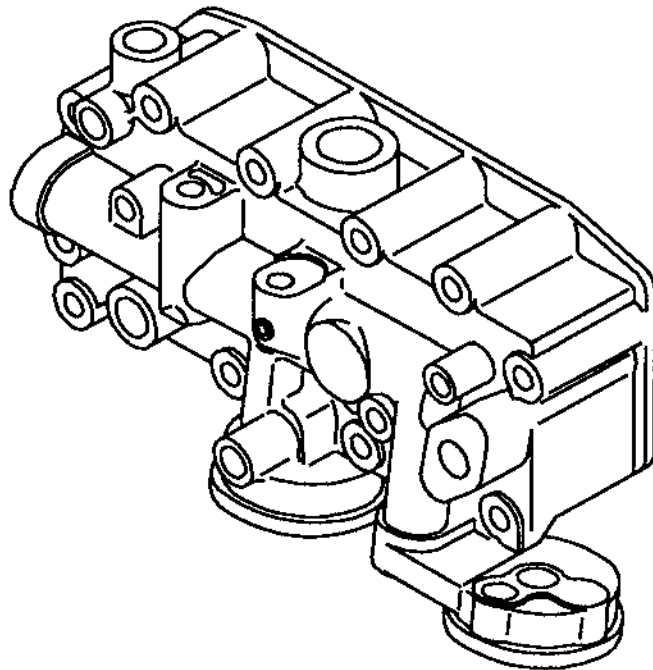

English	Français	Italiano
<p><b>BFM 1012</b></p> <p>1. Remove lube oil cooler from lube oil cooler housing.</p> <p>2. Inspect all single parts and replace if necessary.</p> <p>3. Position new O-seals.</p> <p>4. Mount lube oil cooler. Tighten fastening bolts together with new Cu seals with a torque of <b>20 Nm</b>.</p>	<p><b>BFM 1012</b></p> <p>1. Déposer le radiateur en le sortant de son boîtier.</p> <p>2. Contrôler visuellement toutes les pièces, au besoin les remplacer.</p> <p>3. Placer des joints toriques neufs.</p> <p>4. Monter le radiateur. Serrer au couple de <b>20 Nm</b> les vis de fixation en utilisant des bagues Cu neuves.</p>	<p><b>BFM 1012</b></p> <p>1. Estrarre dalla sua carcassa il refrigeratore dell'olio lubrificante.</p> <p>2. Controllare le singole parti e sostituirle qualora necessario.</p> <p>3. Montare nuovi O-Rings</p> <p>4. Introdurre nuovamente il refrigeratore nella sua carcassa. Bloccare le viti di fissaggio con una coppia di <b>20 Nm</b> dopo averle munite di nuovi anelli di rame.</p>

Deutsch

Werkstatthandbuch BFM 1012/E, BFM 1013/E

**BFM 1012**

1. Schmierölkühler aus Schmierölkühlergehäuse ausbauen.

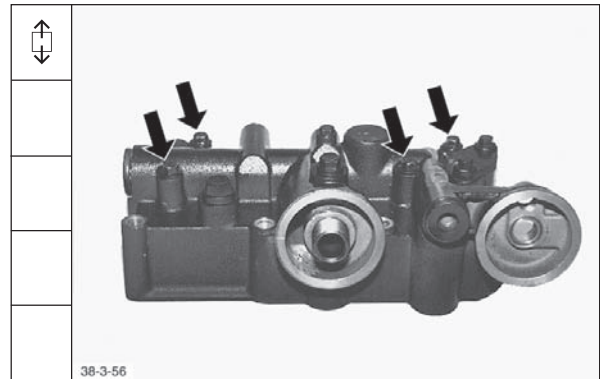

2. Alle Teile sichtprüfen, ggf. austauschen.

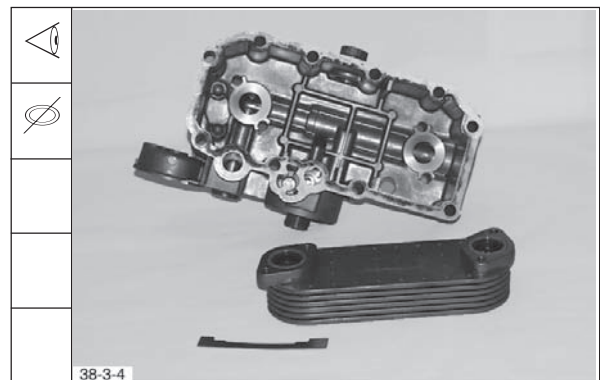

3. Neue Runddichtringe auflegen.



4. Ölkühler in Ölkühlergehäuse montieren. Befestigungsschrauben mit neuen CU-Ringen und einem Drehmoment von **20 Nm** festdrehen.

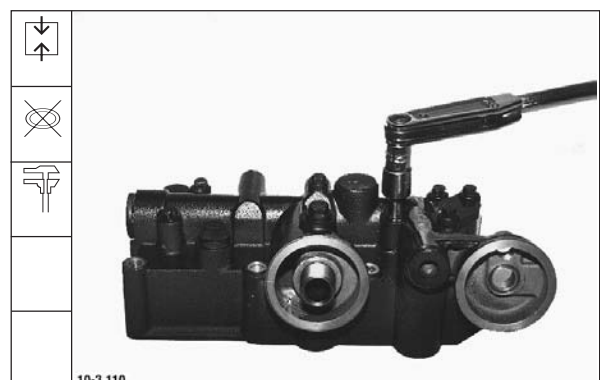

Werkstatthandbuch BFM 1012/E, BFM 1013/E

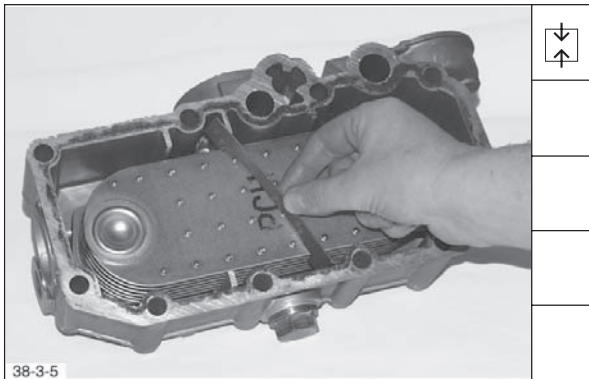

Deutsch

- Bei **BF4M** Sperrblech in Ölfiltergehäuse einsetzen.



English	Français	Italiano
5. On <b>BF4M</b> insert restrictor plate in oil filter housing.	5. Pour le moteur <b>BF4M</b> placer la tôle d'arrêt dans le carter du filtre à huile.	5. Per il motore <b>BF4M</b> installare la lamiera d'arresto nella carcassa del filtro dell'olio.

English	Français	Italiano
<b>BFM 1013</b>	<b>BFM 1013</b>	<b>BFM 1013</b>
1. Remove screw plug.	1. Déposer le bouchon de fermeture.	1. Smontare i tappi.
2. Remove collar screws.	2. Déposer les boulons à embase.	2. Smontare le viti con spallamento.
3. Inspect all single parts and replace if necessary.	3. Contrôler visuellement toutes les pièces, au besoin les remplacer.	3. Controllare tutti i particolari, sostituendoli qualora necessario.
4. Place oil cooler into oil cooler housing.	4. Introduire le radiateur à huile dans le carter de radiateur.	4. Introdurre il refrigeratore nella sua carcassa.

Deutsch

Werkstatthandbuch BFM 1012/E, BFM 1013/E

**BFM 1013**

1. Verschlußstopfen ausbauen.

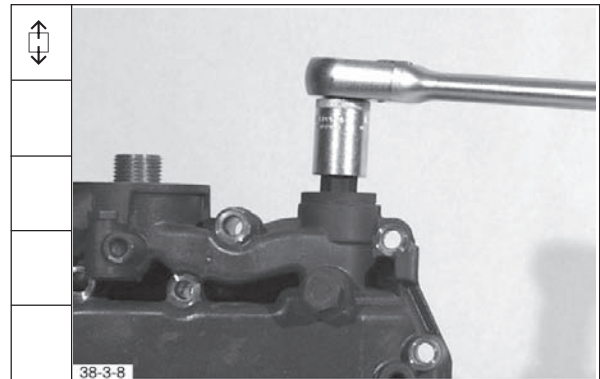

2. Bundschrauben ausbauen.

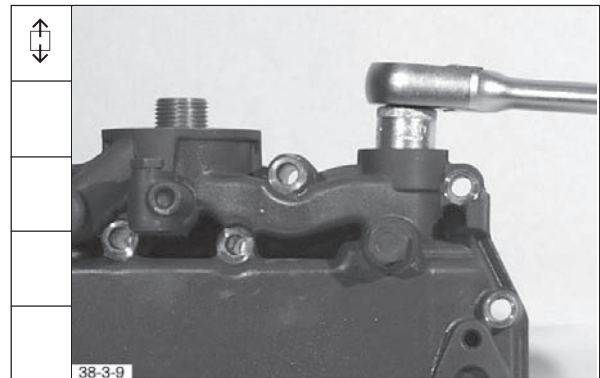

3. Alle Teile sichtprüfen, ggf. austauschen.

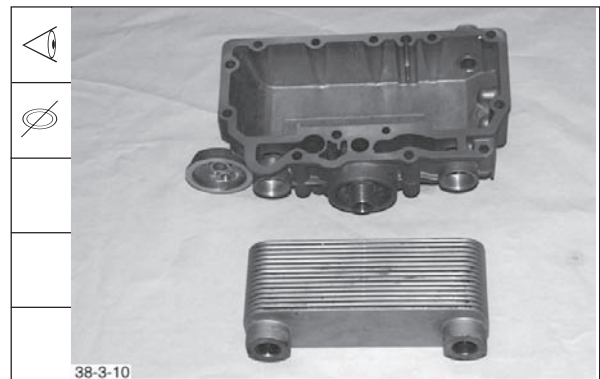

4. Ölkühler in Ölkühlergehäuse einsetzen.

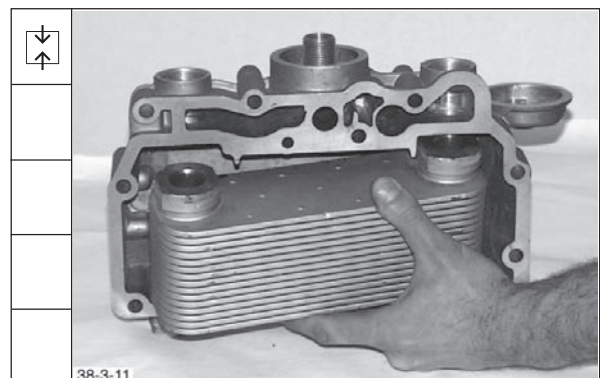

Werkstatthandbuch BFM 1012/E, BFM 1013/E

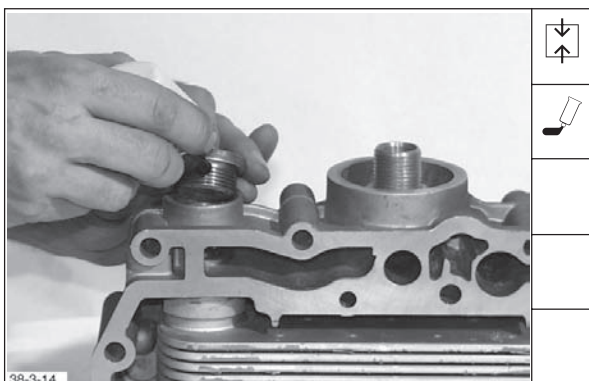
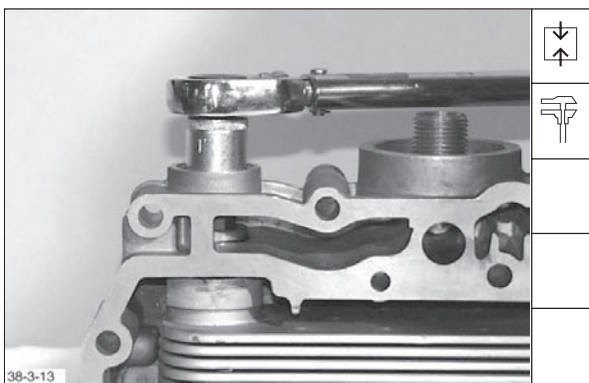
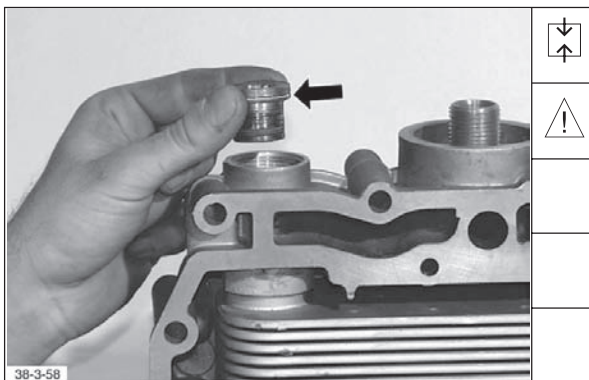
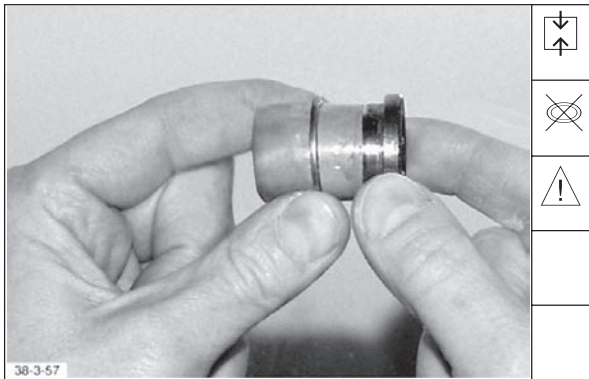

Deutsch

5. Neuen Dichtring auf Bundschraube montieren.

**Hinweis:** Für Montage des Dichtringes Gewinde abdecken.

6. Bundschrauben montieren.

**Hinweis:** Dichtringe leicht einölen.

7. Bundschrauben festdrehen.

Anziehvorschrift:  
 Vorspannen  
 Nachspannen

**80 Nm**  
**160 Nm.**

8. Neuen Runddichtring auf Verschlussschraube montieren und mit Montagemittel **AP 25 N** bestreichen.

English	Français	Italiano
<p>5. Fit new sealing ring to collar screw.</p> <p><b>Note:</b> Cover thread when fitting sealing rings.</p>	<p>5. Monter le joint d'étanchéité neuf sur la vis d'assemblage.</p> <p><b>Nota:</b> pour le montage du joint d'étanchéité recouvrir le filetage.</p>	<p>5. Montare un nuovo anello di tenuta sulle viti con spallamento</p> <p><b>Nota:</b> Per montare l'anello di tenuta coprire la parte filettata.</p>
<p>6. Fit collar screws.</p> <p><b>Note:</b> Lightly oil sealing rings.</p>	<p>6. Mettre en place les boulons à embase.</p> <p><b>Nota:</b> huiler légèrement les joints d'etanchéité.</p>	<p>6. Montare le viti con spallamento filettate.</p> <p><b>Nota:</b> Oliare leggermente gli anelli di tenuta.</p>
<p>7. Tighten collar screws.  Tightening specification:  Initial tightening <b>80 Nm</b>  Final tightening <b>160 Nm.</b></p>	<p>7. Serrer les vis d'assemblage.  Consigne de serrage:  serrage d'approche <b>80 Nm</b>  serrage définitif <b>160 Nm.</b></p>	<p>7. Bloccare le viti con spallamento.  Prescrizioni di serraggio:  Preserraggio <b>80 Nm</b>  Serraggio finale <b>160 Nm</b></p>
<p>8. Fit new O-seal to screw plug and apply lubricant <b>AP 25 N.</b></p>	<p>8. Monter le joint torique d'etanchéité sur la vis filetée et enduire de produit de montage <b>AP 25 N.</b></p>	<p>8. Munire il tappo filettato di un nuovo O-Ring ed applicarci il prodotto <b>AP 25 N.</b></p>



English	Français	Italiano
9. Tighten screw plug. Tightening specification: <b>80 Nm</b> .	9. Serrer le bouchon de fileté Consigne de serrage <b>80 Nm</b> .	9. Bloccare il tappo filettato. Prescrizioni di serraggio: <b>80 Nm</b>
10. Insert restrictor plate, if any.	10. Selon l'équipement du moteur remonter le clapet de fermeture.	10. Inserire la piastra d'arresto, qualora esista.

Deutsch

Werkstatthandbuch BFM 1012/E, BFM 1013/E

9. Verschlußstopfen festdrehen  
Anziehvorschrift: **80 Nm**.

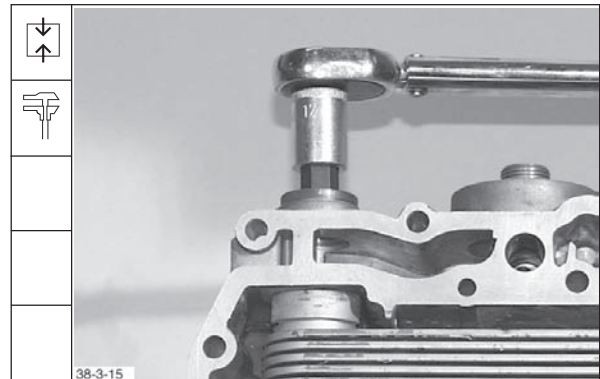

10. Falls vorhanden: Absperrklappe einsetzen.

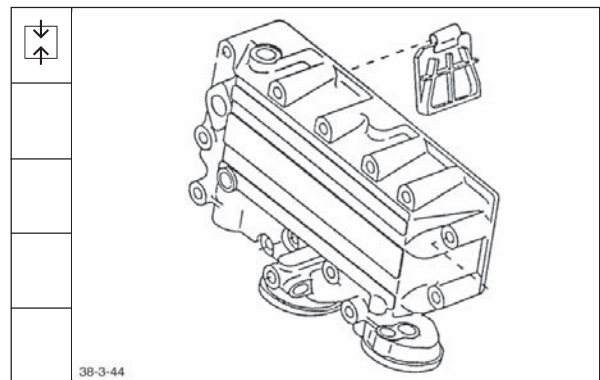

**Bauteile instand setzen**  
**Repair of components**  
**Mise en état des composants**  
**Riparazione dei componenti**

---



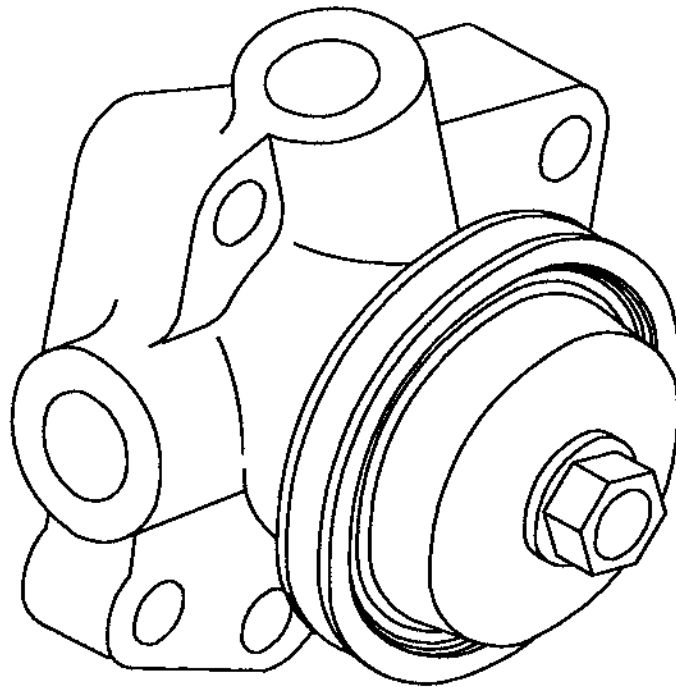

English	Français	Italiano
<p>1. Remove clamping plate. Inspect fuel pump/clamping plate and replace if necessary.</p>	<p>1. Déposer la griffe de serrage. Contrôler visuellement la pompe à combustible / griffe de serrage, au besoin les remplacer.</p>	<p>1. Smontare il tirante. Controllare la pompa del combustibile ed il tirante, sostituendoli qualora necessario.</p>
<p>2. Fit clamping plate and tighten bolts with a torque of <b>22 ± 2 Nm</b>.</p>	<p>2. Monter la griffe de serrage. Serrer les vis au couple de <b>22 ± 2 Nm</b>.</p>	<p>2. Rimontare il tirante e serrare le viti con una coppia di <b>22 ± 2 Nm</b>.</p>

Deutsch

Werkstatthandbuch BFM 1012/E, BFM 1013/E

1. Spannlasche abbauen. Kraftstoffpumpe /  
Spannlasche sichtprüfen, ggf. austauschen.



2. Spannlasche anbauen Schrauben mit einem  
Drehmoment von  $22 \pm 2$  Nm festdrehen.



**Bauteile instand setzen**  
**Repair of components**  
**Mise en état des composants**  
**Riparazione dei componenti**

---

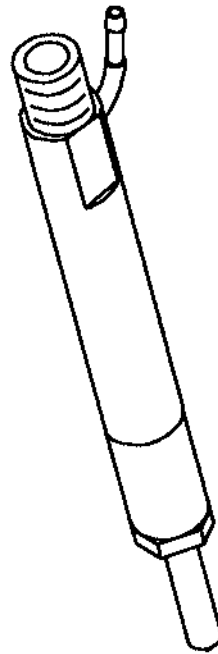

English	Français	Italiano
<p><b>Commercial tool required:</b> Long socket, serrated, a/flats 15 8012</p> <p><b>Special tool required:</b> Assembly tool _____ 110 110</p>	<p><b>Outillage usuel :</b> Longue clé à douille polygonale de 15 _____ 8012</p> <p><b>Outillage spécial :</b> Dispositif de montage _____ 110 110</p>	<p><b>Attrezzo normale:</b> Chiave a bussola lunga SW 15 _ 8012</p> <p><b>Attrezzo speciale:</b> Dispositivo di montaggio ____ 110 110</p>
<p>1. Unscrew cap nut.</p> <p>2. Sequence of parts disassembly</p> <ol style="list-style-type: none"><li>1. Cap nut</li><li>2. Injection nozzle</li><li>3. Adapter</li><li>4. Thrust pin</li><li>5. Compression spring</li><li>6. Shim</li></ol>	<p>1. Dévisser l'écrou-raccord.</p> <p>2. Ordre de démontage des pièces</p> <ol style="list-style-type: none"><li>1. Ecrou-raccord</li><li>2. Injecteur comprenant corps d'injecteur et aiguille</li><li>3. Élément intermédiaire</li><li>4. Tige poussoir</li><li>5. Ressort</li><li>6. Rondelle d'épaisseur</li></ol>	<p>1. Svitare il dado di raccordo</p> <p>2. Sequenza dello smontaggio</p> <ol style="list-style-type: none"><li>1. Dado a risvolto</li><li>2. Iniettore</li><li>3. Pezzo intermedio</li><li>4. Perno premente</li><li>5. Molla premente</li><li>6. Rondella di spessore</li></ol>
<p>Wash all parts in clean diesel fuel and blow out with compressed air.</p>	<p>Nettoyer toutes les pièces dans du combustible Diesel et les sécher au jet d'air comprimé.</p>	<p>Risciacquare tutti i particolari in gasolio pulito ed asciugarli con un getto di aria compressa.</p>
<p>3. Nozzle needle and nozzle body are lapped together and must neither be confused nor exchanged individually. Do not touch nozzle needles with your fingers. When nozzle body is held in upright position, nozzle needle should by its own weight slide down slowly and smoothly on its seating.</p>	<p>3. L'aiguille et la buse de l'injecteur sont appariées et rodées ensemble, elles ne doivent pas être interverties ni changées séparément. Ne pas prendre l'aiguille avec les doigts. L'injecteur étant tenu verticalement l'aiguille doit retomber d'elle-même lentement dans son logement.</p>	<p>3. L'ago ed il corpo del polverizzatore sono lappati assieme, e non possono venire né scambiati né sostituiti singolarmente. Evitare di toccare con le dita l'ago del polverizzatore: tenendo verticale il corpo del polverizzatore, l'ago deve scivolare lentamente e senza scosse nella sua sede, spinto dal suo stesso peso.</p>
<p><b>Note:</b> If nozzle needle does not slide down smoothly, wash injection nozzle again in diesel fuel. Renew, if necessary. New injection nozzle must likewise be washed in clean diesel fuel.</p>	<p><b>Nota:</b> si l'aiguille de l'injecteur ne glisse pas librement dans son logement la laver une nouvelle fois, si nécessaire renouveler l'injecteur. Penser à laver tout injecteur neuf dans du gazole propre.</p>	<p><b>Nota:</b> Se l'ago non scivola liberamente, l'intero polverizzatore deve venire nuovamente lavato in gasolio, altrimenti deve venire sostituito. Anche il nuovo polverizzatore deve venire lavato in gasolio pulito.</p>

**Deutsch**

**Werkstatthandbuch BFM 1012/E, BFM 1013/E**

**Handelsübliches Werkzeug:**

Lange Stecknuß, SW15 Vielzahn \_\_\_\_\_ 8012

**Spezialwerkzeug:**

Montagevorrichtung \_\_\_\_\_ 110 110

1. Überwurfmutter abschrauben.

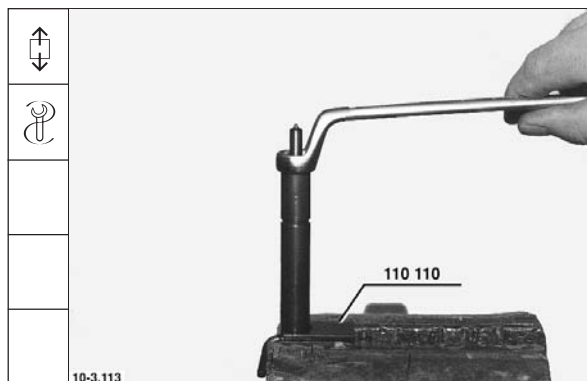

2. Folge der Einzeldemontage

1. Überwurfmutter
2. Einspritzdüse
3. Zwischenstück
4. Druckbolzen
5. Druckfeder
6. Ausgleichscheibe

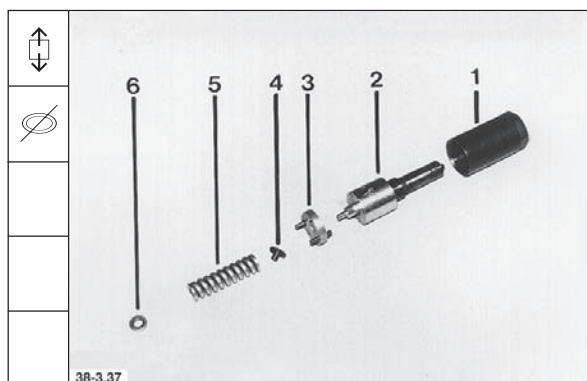

Sämtliche Teile in sauberem Dieselkraftstoff reinigen und mit Druckluft ausblasen.

3. Düsennadel und Düsenkörper sind zusammen geläppt und dürfen weder vertauscht noch einzeln ausgetauscht werden. Düsennadel nicht mit den Fingern berühren. Die Düsennadel muß bei senkrecht gehaltenem Düsenkörper durch ihr Eigengewicht langsam und ruckfrei auf ihren Sitz gleiten.



**Hinweis:** Bei ruckweisem Abgleiten der Düsennadel die Einspritzdüse erneut in Dieselkraftstoff auswaschen, bei Bedarf erneuern. Neue Einspritzdüse ebenfalls in sauberem Dieselkraftstoff reinigen.

Werkstatthandbuch BFM 1012/E, BFM 1013/E

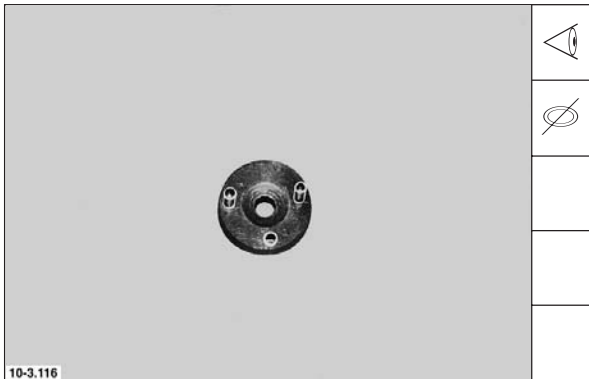

Deutsch

4. Sitzflächen des Zwischenstückes auf Verschleiß prüfen. Auf Vorhandensein der Zentrierstifte achten.

5. Ausgleichscheibe einsetzen.

**Hinweis:** Der Abspritzdruck ist von der Dicke der Ausgleichscheibe abhängig.

6. Druckfeder einsetzen.

7. Druckbolzen mit dem Zentrierbund zur Druckfeder weisend einsetzen.



English	Français	Italiano
4. Check seating surfaces of adapter for wear. Make sure that centering pins are fitted.	4. Vérifier l'usure des surfaces portantes de la pièce intermédiaire. Veiller à ce que les pions de centrage soient bien en place.	4. Verificare che le superfici del seggio del pezzo intermedio non siano usurate. Controllare la presenza delle spine di centraggio.
5. Insert shim.  <b>Note:</b> The injection pressure is dependent on the shim thickness.	5. Placer la rondelle d'épaisseur.  <b>Nota:</b> la pression de tarage dépend de l'épaisseur de la rondelle d'épaisseur.	5. Inserire gli spessori.  <b>Nota:</b> La pressione d'iniezione dipende dagli spessori.
6. Insert compression spring.	6. Placer le ressort de pression.	6. Inserire la molla premente.
7. Insert thrust pin with centering collar facing towards compression spring.	7. Placer la tige poussoir en orientant la collerette de centrage vers le ressort.	7. Inserire il perno premente col suo collarino di centraggio rivolto verso la molla.

**English**

8. Insert adapter with centering pins into the bores of the nozzle holder.

**Note:** The recess points to the thrust pin.

9. Fit injection nozzle with center bores mating with the centering pins of the adapter.

**Note:** Take care that nozzle needle does not fall out of nozzle body.

10. Screw on cap nut.

11. Tighten cap nut with a torque of **40 - 50 Nm**.

**For testing and adjusting injector see chapter 2.**

**Français**

8. Placer la pièce intermédiaire avec les pions de centrage dans les alésages du porte-injecteur.

**Nota:** le lamage doit être orienté vers la tige poussoir.

9. Placer l'injecteur avec les alésages de centrage sur les pions de centrage de la pièce intermédiaire.

**Nota:** ne pas faire tomber l'aiguille de l'injecteur.

10. Visser la vis raccord.

11. Bloquer la vis raccord au couple de **40 - 50 Nm**.

**Pour vérifier et caler l'injecteur, voir chapitre 2.**

**Italiano**

8. Inserire il pezzo intermedio facendo attenzione che le spine di centraggio entrino nei fori del porta-polverizzatore.

**Nota:** La svasatura deve essere rivolta verso il perno premente.

9. Montare il polverizzatore con i fori di centraggio rivolti verso le spine di centraggio del pezzo intermedio.

**Nota:** Far attenzione che l'ago del polverizzatore non cada fuori dalla propria sede.

10. Avvitare il dado di raccordo.

11. Serrare il dado di raccordo con una coppia di **40 - 50 Nm**.

**Circa controllo e messa a punto dell'inietttore, vedi capitolo 2:**

**Deutsch**

**Werkstatthandbuch BFM 1012/E, BFM 1013/E**

8. Zwischenstück mit den Zentrierstiften in die Bohrungen des Düsenhalters einsetzen.

**Hinweis:** Die Ansenkung weist zum Druckbolzen.



9. Einspritzdüse mit den Zentrierbohrungen auf die Zentrierstifte des Zwischenstückes aufsetzen.

**Hinweis:** Die Düsennadel darf nicht aus dem Düsenkörper fallen.



10. Überwurfmutter aufschrauben.



11. Überwurfmutter mit einem Drehmoment von **40 - 50 Nm** festdrehen.

**Einspritzventil prüfen und einstellen, siehe Kapitel 2.**

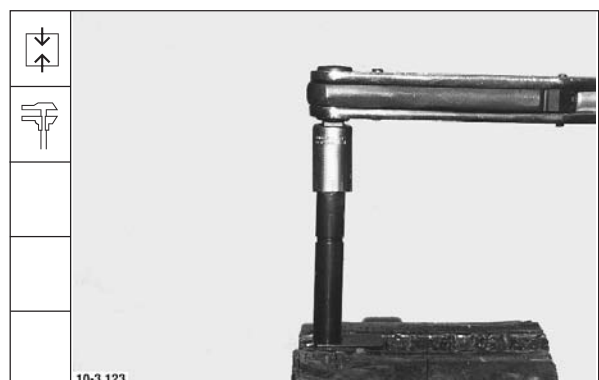

**Bauteile instand setzen**  
**Repair of components**  
**Mise en état des composants**  
**Riparazione dei componenti**

---

Regelstange  
Control rod  
Ceémaillère  
Asta a cremagliera

Bauteile instandsetzen  
Repair of components  
Mise en état des composants  
Riparazione dei componenti

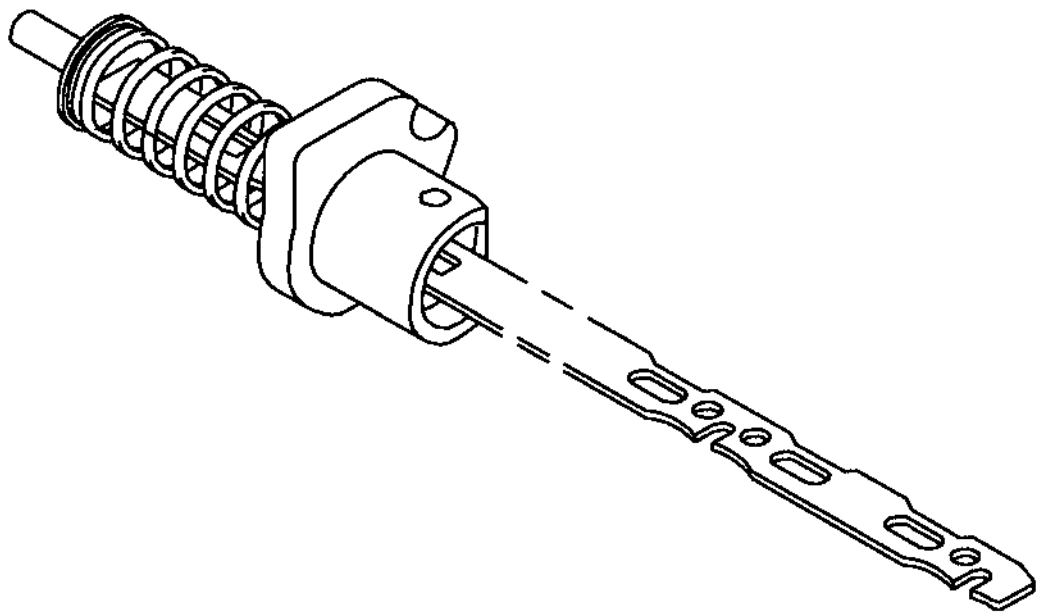

**English**

1. Inspect control rod and renew any damaged parts.

2. Drill guide sleeve apart at dowel pin and remove.

**Note:** When disassembling the control rod always renew guide sleeve and dowel pin.

3. Order of assembly

1. Control rod
2. Dowel pin
3. Guide sleeve
4. Compression spring

4. Watch installation direction of control rod relative to guide sleeve.

**Français**

1. Contrôler visuellement la crémaillère, au besoin remplacer les pièces endommagées.

2. Réaliser la douille de guidage au niveau de la tige de serrage et l'enlever.

**Nota:** au démontage de la crémaillère toujours remplacer la douille de guidage et la tige de serrage.

3. Ordre de montage

1. Crémaillère
2. Tige de serrage
3. Douille de guidage
4. Ressort

4. Veiller au sens de montage de la crémaillère par rapport à la douille de guidage.

**Italiano**

1. Controllare l'asta a cremagliera e sostituirla le parti eventualmente danneggiate.

2. Trapanare la spina elastica sul manicotto di guida e smontare quest'ultimo.

**Nota:** Ogni volta in cui si smonta l'asta a cremagliera si deve assolutamente sostituire la spina elastica ed il manicotto di guida.

3. Sequenza di montaggio

1. Asta a cremagliera
2. Spina elastica
3. Manicotto di guida
4. Molla premente.

4. Fare attenzione alla direzione di montaggio dell'asta a cremagliera rispetto al manicotto di guida.

**Deutsch**

**Werkstatthandbuch BFM 1012/E, BFM 1013/E**

1. Regelstange sichtprüfen ggf. beschädigte Teile austauschen.

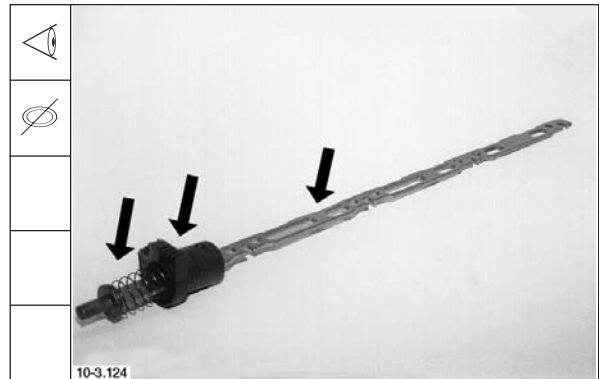

2. Führungsbuchse am Spannstift aufbohren und entfernen.

**Hinweis:** Bei Demontage der Regelstange ist grundsätzlich die Führungshülse und der Spannstift zu erneuern.

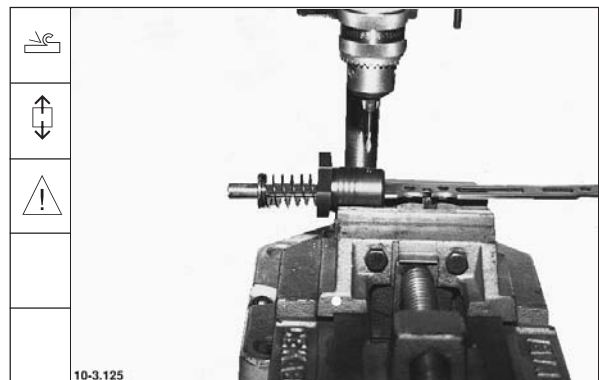

3. Reihenfolge bei der Montage

1. Regelstange
2. Spannstift
3. Führungsbuchse
4. Druckfeder

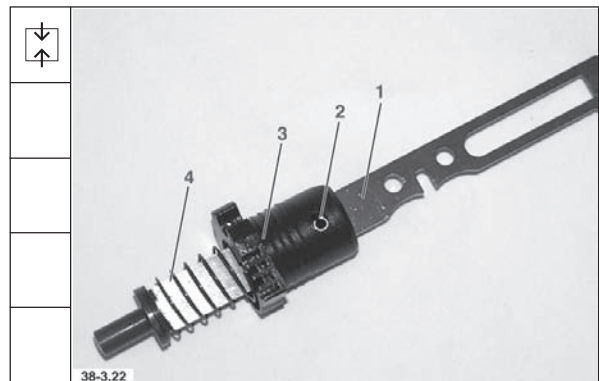

4. Einbaurichtung der Regelstange zur Führungsbuchse beachten.



Werkstatthandbuch BFM 1012/E, BFM 1013/E

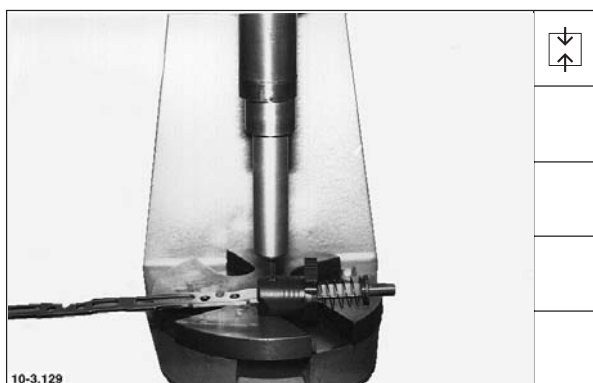
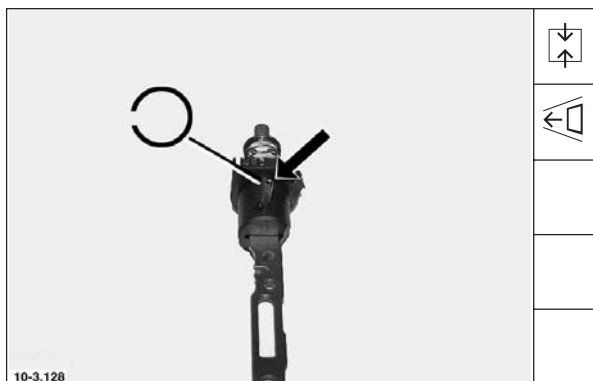

Deutsch

5. Spannstift so einsetzen, daß die Öffnung quer zur Regelstange weist.

6. Spannstift bis Anlage eindrücken.



English	Français	Italiano
5. Insert dowel pin so that opening points in transverse position towards control rod.	5. Placer la tige de serrage de manière à ce que l'ouverture se trouve dans le sens transversal à la crémaillère.	5. Inserire la spina elastica in modo che l'apertura risulti trasversale rispetto all'asta a cremagliera.
6. Press in dowel pin as far as it will go.	6. Insérer la tige de serrage jusqu'en butée.	6. Spingere la spina elastica fino a battuta.

**Bauteile instand setzen**  
**Repair of components**  
**Mise en état des composants**  
**Riparazione dei componenti**

---

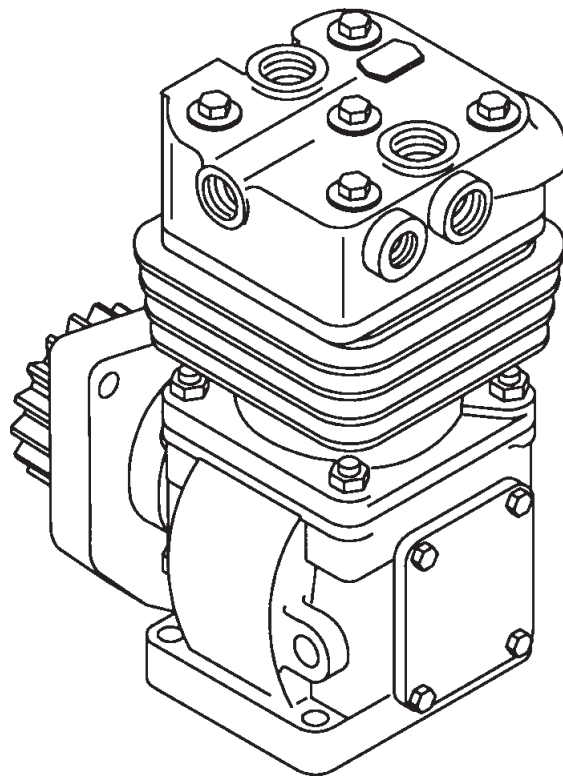

English	Français	Italiano
<p><b>Special tool required:</b></p> <p>Retainer for air compressor gear _____170 630</p> <p>Air compressor has been removed.</p> <ol style="list-style-type: none"><li>1. Slide retainer onto gear. Loosen lock nut.</li><li>2. Pull off gear with commercial two-armed extractor.</li><li>3. Place on gear and start lock nut.</li></ol> <p><b>Note:</b> Before fitting gear, make absolutely sure that the cones of gear and shaft are free of lubricant, clean and undamaged.</p> <ol style="list-style-type: none"><li>4. Slide retainer onto gear and tighten lock nut with a torque of <b>200 + 50 Nm.</b></li></ol>	<p><b>Outillage spécial:</b></p> <p>Dispositif d'immobilisation pour pignon de compresseur d'air _____170 630</p> <p>Dépose de compresseur d'air.</p> <ol style="list-style-type: none"><li>1. Introduire le dispositif d'immobilisation sur le pignon et desserrer l'écrou de fixation.</li><li>2. Extraire le pignon à l'aide d'un extracteur usuel à deux bras.</li><li>3. Placer le pignon et visser à la main l'écrou de fixation.</li></ol> <p><b>Nota:</b> avant le montage du pignon veiller impérativement à ce que les cones du pignon soient dépourvus de tout reste de lubrifiant, parfaitement propres et sans aucun dommage.</p> <ol style="list-style-type: none"><li>4. Introduire le dispositif d'immobilisation sur le pignon et serrer l'écrou de fixation au couple de <b>200 + 50 Nm.</b></li></ol>	<p><b>Attrezzo speciale</b></p> <p>Sbarra per bloccare la ruota dentata del compressore _____ 170 630</p> <p>Il compressore è smontato dal motore.</p> <ol style="list-style-type: none"><li>1. Applicare la sbarra sulla ruota dentata. Svitare il dado di fissaggio.</li><li>2. Smontare la ruota dentata per mezzo di un normale estrattore a due braccia.</li><li>3. Piazzare la ruota dentata ed avvitare il dado di fissaggio.</li></ol> <p><b>Nota:</b> Prima di montare la ruota dentata ci si deve accertare che i coni tra la ruota dentata e l'albero siano intatti, senza grasso e puliti.</p> <ol style="list-style-type: none"><li>4. Applicare la sbarra sulla ruota dentata e serrare il dado di fissaggio con una coppia di <b>200 + 50 Nm.</b></li></ol>

Deutsch

Werkstatthandbuch BFM 1012/E, BFM 1013/E

Spezialwerkzeug

Gegenhalter  
für Luftpresser-Zahnrad \_\_\_\_\_ 170 630

Luftpresser ist abgebaut.

1. Gegenhalter auf Zahnrad aufschieben.  
Befestigungsmutter lösen.

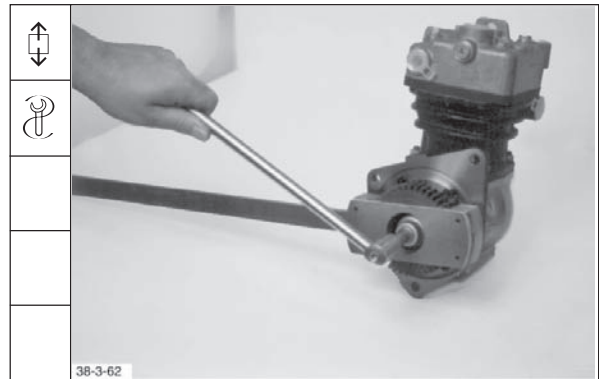

2. Zahnrad mit handelsüblichen zweiarmigen Abzieher abziehen.

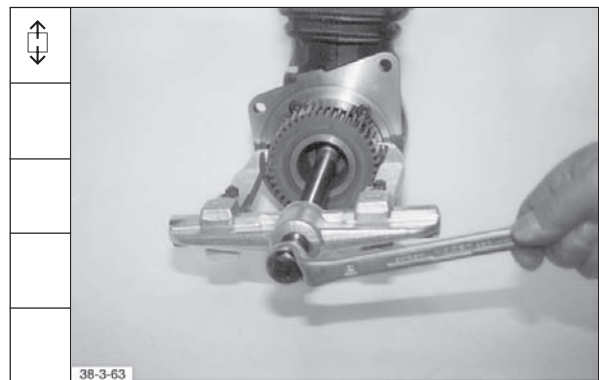

3. Zahnrad aufsetzen und Befestigungsmutter beidrehen.

**Hinweis:** Vor Montage des Zahnrades ist unbedingt darauf zu achten, daß die Konen von Zahnrad und Welle schmiermittelfrei, sauber und ohne Beschädigung sind.



4. Gegenhalter auf Zahnrad aufschieben und Befestigungsmutter mit einem Drehmoment von **200 + 50 Nm** festdrehen.



**Bauteile instand setzen**  
**Repair of components**  
**Mise en état des composants**  
**Riparazione dei componenti**

---

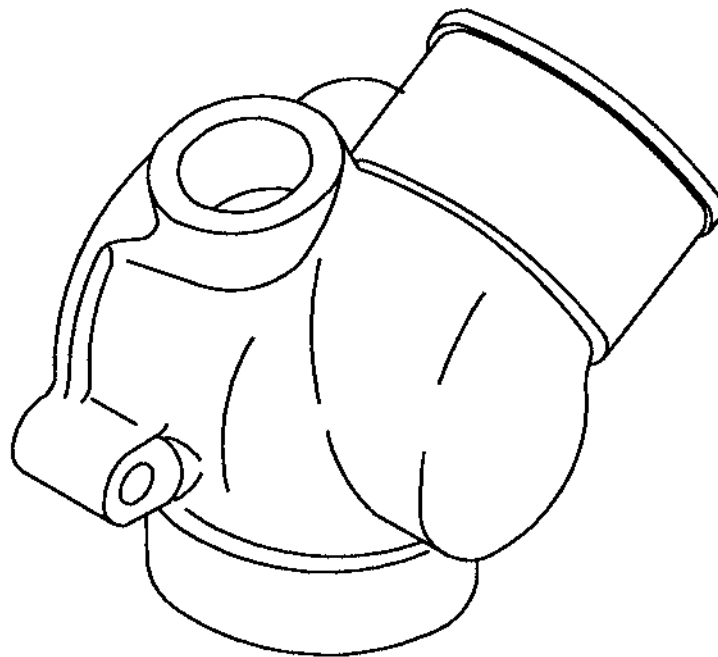





Deutsch

Werkstatthandbuch BFM 1012/E, BFM 1013/E

Spezialwerkzeug:

Montagewerkzeug für  
 Kühlmittelthermostat \_\_\_\_\_ 170 090

1. Thermostat niederdrücken und aus Thermostatgehäuse herausnehmen.



2. Alle Teile sichtprüfen, ggf. austauschen.



3. Thermostat niederdrücken und in Thermostatgehäuse hineindrehen.

**Hinweis:** Spannbügel muß im Thermostatgehäuse einrasten.



**Bauteile instand setzen**  
**Repair of components**  
**Mise en état des composants**  
**Riparazione dei componenti**

---

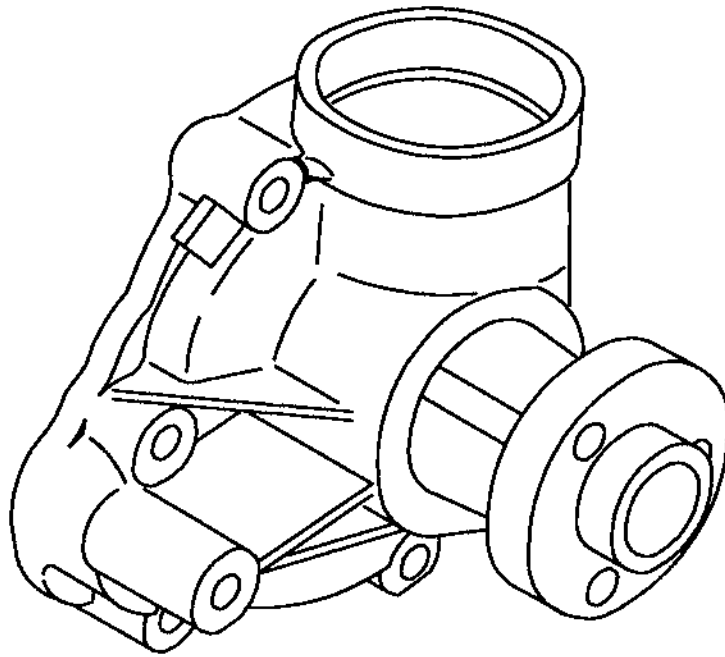

English	Français	Italiano
1. Remove V-belt pulley.	1. Déposer la poulie à gorge.	1. Smontare la puleggia della cinghia trapezoidale.
2. Inspect all single parts and replace if necessary.	2. Contrôler visuellement toutes les pièces, les remplacer au besoin.	2. Controllare tutte le parti e sostituirle qualora necessario.
3. Fit V-belt pulley. Tighten bolts with a torque of <b>21 Nm</b> .	3. Monter la poulie. Serrer les vis au couple de <b>21 Nm</b> .	3. Rimontare la puleggia della cinghia trapezoidale. Serrare le viti con una coppia di <b>21 Nm</b> .

Deutsch

Werkstatthandbuch BFM 1012/E, BFM 1013/E

1. Keilriemenscheibe abbauen.

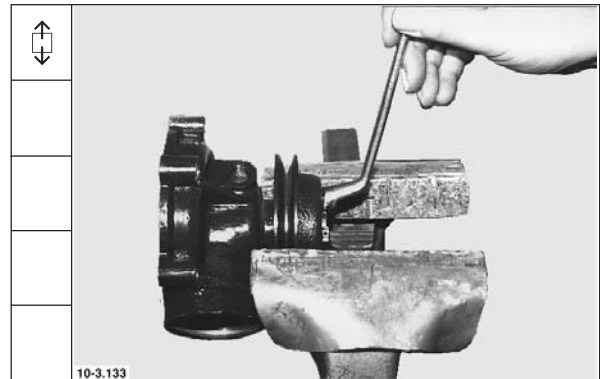

2. Alle Teile sichtprüfen, ggf. austauschen.



3. Keilriemenscheibe montieren. Schrauben mit einem Drehmoment von **21 Nm** festdrehen.



**Bauteile instand setzen**  
**Repair of components**  
**Mise en état des composants**  
**Riparazione dei componenti**

---

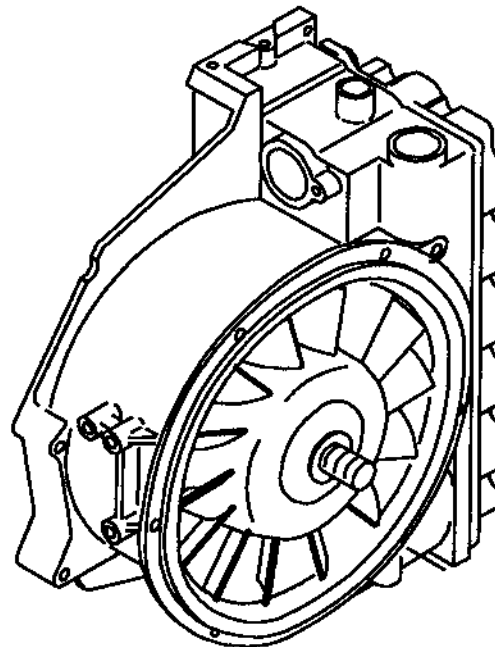

English	Français	Italiano
<p><b>Only BFM 1012 documented</b></p> <p><b>Special tool required:</b></p> <p>Extractor _____ 150 800</p>	<p><b>Seulement BFM 1012</b></p> <p><b>Outillage spécial :</b></p> <p>Extracteur _____ 150 800</p>	<p><b>Viene documentato soltanto il BFM 1012</b></p> <p><b>Attrezzo speciale:</b></p> <p>Estrattore _____ 150 800</p>
<p>1. Remove cover.</p>	<p>1. Déposer le couvercle.</p>	<p>1. Smontare il coperchio.</p>
<p>2. Take out circlip for delivery valve. Remove delivery valve.</p>	<p>2. Retirer le circlip de la soupape de refoulement. Déposer cette dernière.</p>	<p>2. Estrarre l'anello di sicurezza della valvola di mandata. Smontare la valvola di mandata.</p>
<p>3. Inspect single parts and replace if necessary.</p>	<p>3. Contrôler visuellement les pièces, au besoin les remplacer.</p>	<p>3. Controllare le varie parti e sostituirle qualora necessario.</p>



**Deutsch**

**Werkstatthandbuch BFM 1012/E, BFM 1013/E**

**Nur BFM 1012 dokumentiert**

**Spezialwerkzeug:**

Auszehvorrichtung \_\_\_\_\_ 150 800

1. Deckel abbauen.



2. Sicherungsring für Druckventil herausnehmen. Druckventil ausbauen.



3. Teile sichtprüfen, ggf. erneuern.



**Werkstatthandbuch BFM 1012/E, BFM 1013/E**

**Deutsch**



10-3.139

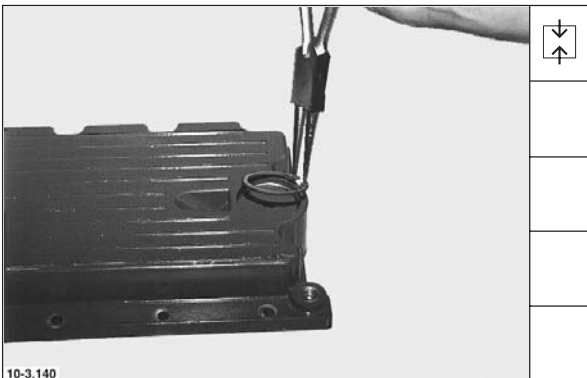

10-3.140

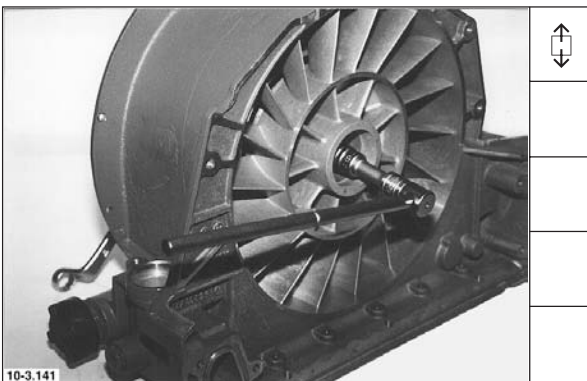

10-3.141



10-3.142

4. Druckventil einsetzen.

5. Sicherungsring einsetzen.

6. Zentralverschraubung lösen. Keilriemenscheibe und Läufer abnehmen.

7. Druckstück herausnehmen.

English	Français	Italiano
4. Insert delivery valve.	4. Mettre en place la soupape de refoulement.	4. Montare la valvola di mandata.
5. Insert circlip.	5. Introduire le circlip.	5. Inserire l'anello di sicurezza.
6. Loosen central bolt. Remove V-belt pulley and rotor.	6. Desserrer le boulon central. Retirer la poulie à gorge et le rotor.	6. Allentare la vite centrale. Smontare la puleggia della cinghia trapezoidale e la girante.
7. Take out thrust piece.	7. Retirer la rondelle de pression.	7. Estrarre la rondella di spinta.



English	Français	Italiano
8. Screw on washer using extractor.	8. Visser la poulie et l'extracteur.	8. Avvitare la puleggia con l'estrattore.
9. Pull ball bearings (2x) together with spacer sleeve completely out of blower carrier.	9. Retirer du support de la soufflante l'ensemble des roulements à bille au nombre de deux avec la douille d'écartement.	9. Estrarre dal supporto della ventola i cuscinetti a sfere (2) assieme alla boccola distanziatrice.
10. Inspect all single parts and replace if necessary.	10. Contrôler visuellement les pièces, au besoin les remplacer.	10. Controllare tutti i particolari e sostituirli qualora necessario.
11. Press small ball bearing in over outer race as far as it will go.	11. Introduire le petit roulement à billes par la bague extérieure jusqu'en position de butée.	11. Far entrare il piccolo cuscinetto a sfere al di sopra dell'anello esterno spingendolo fino a battuta.

**Deutsch**

**Werkstatthandbuch BFM 1012/E, BFM 1013/E**

8. Scheibe mit Ausziehvorrichtung verschrauben.

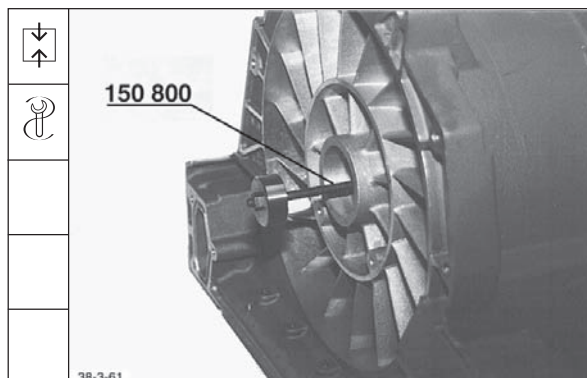

9. Kugellager (2 Stück) mit Distanzbuchse komplett aus Gebläseträger herausziehen.

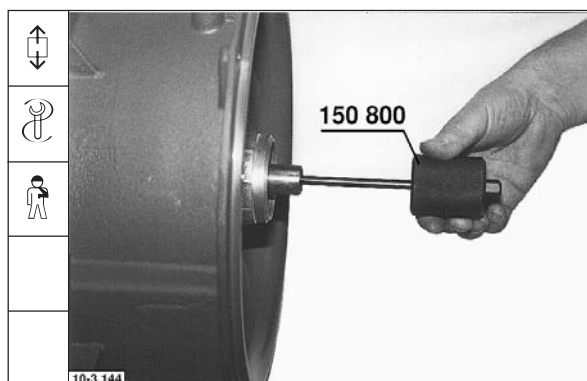

10. Alle Teile sichtprüfen, ggf. erneuern.

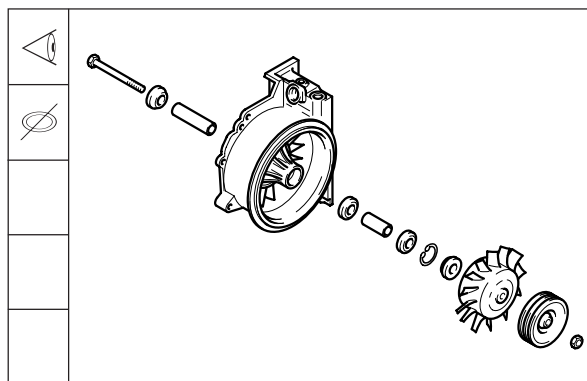

11. Kleines Kugellager über den Außenring bis Anlage eindrücken.



**Werkstatthandbuch BFM 1012/E, BFM 1013/E**

**Deutsch**



12. Distanzbuchse einsetzen. Großes Kugellager über den Außenring bis Anlage eindrücken.

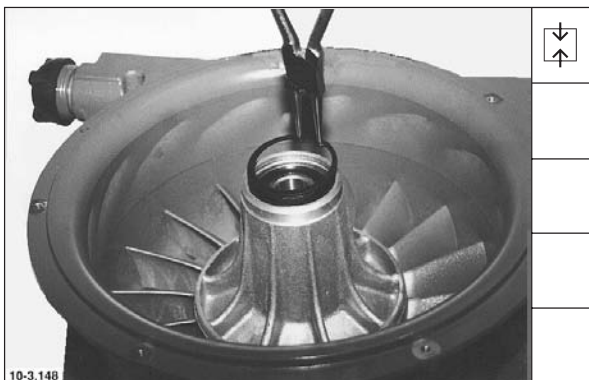

13. Sicherungsring montieren.

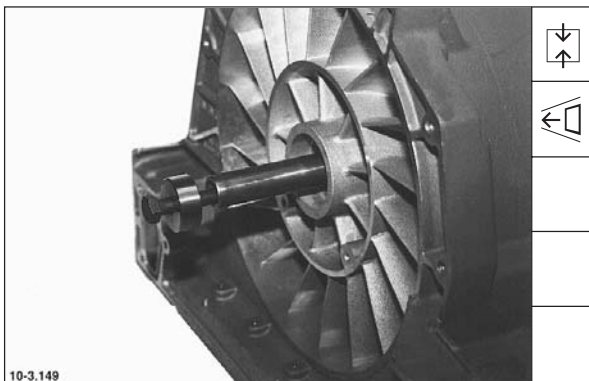

14. Hohlwelle mit Schraube und Scheibe durch Distanzbuchse führen.



15. Druckstück aufsetzen.

English	Français	Italiano
12. Insert spacer sleeve. Press large ball bearing in over outer race as far as it will go.	12. Placer la douille d'écartement. Introduire le grand roulement à billes par la bague extérieure jusqu'en position de butée.	12. Montare la boccola distanziatrice. Montare il grande cuscinetto a sfere al di sopra dell'anello esterno, spingendolo fino a battuta.
13. Fit circlip.	13. Monter le circlip.	13. Montare l'anello di sicurezza.
14. Introduce hollow shaft together with bolt and washer into spacer sleeve.	14. Faire passer l'arbre creux avec vis et rondelle à travers la douille d'écartement.	14. Infilare l'albero cavo con vite e rondella attraverso la boccola distanziatrice.
15. Position thrust piece.	15. Placer la rondelle de pression.	15. Montare la rondella di spinta.

English	Français	Italiano
16. Position rotor and V-belt pulley in place.	16. Placer le rotor et la poulie à gorge.	16. Montare il rotore e la puleggia della cinghia trapezoidale.
17. Hold central bolt in place and tighten new nut with a torque of <b>120 Nm</b> .	17. Maintenir la vis centrale et serrer l'écrou neuf au couple de <b>120 Nm</b> .	17. Tenendo bloccata la vite centrale serrare il nuovo dado con una coppia di <b>120 Nm</b> .
<b>Note:</b> In each case of repair use new nut of DIN 934-M12-10 quality.	<b>Nota:</b> à chaque réparation utiliser un écrou neuf répondant à la qualité DIN 934-M12-10.	<b>Nota:</b> In occasione di ogni riparazione si deve far uso di un nuovo dado nella qualità DIN 934-M12-10.
18. Place new gasket in position.	18. Placer un joint neuf.	18. Montare una nuova guarnizione.
19. Fit cover. Tighten bolts with a torque of <b>9 Nm</b> .	19. Monter le couvercle. Serrer les vis au couple de <b>9 Nm</b> .	19. Montare il coperchio. Serrare le viti con una coppia di <b>9 Nm</b> .



Deutsch

Werkstatthandbuch BFM 1012/E, BFM 1013/E

16. Läufer und Keilriemenscheibe aufsetzen.

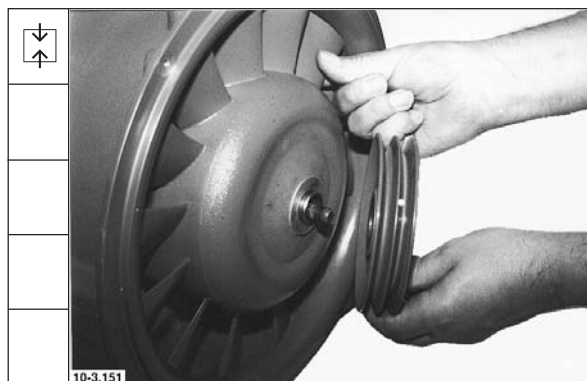

17. Zentralschraube gegenhalten und neue Mutter mit einem Drehmoment von **120 Nm** festdrehen.

**Hinweis:** Bei jeder Reparatur ist eine neue Mutter der Qualität DIN 934-M12-10 zu verwenden.

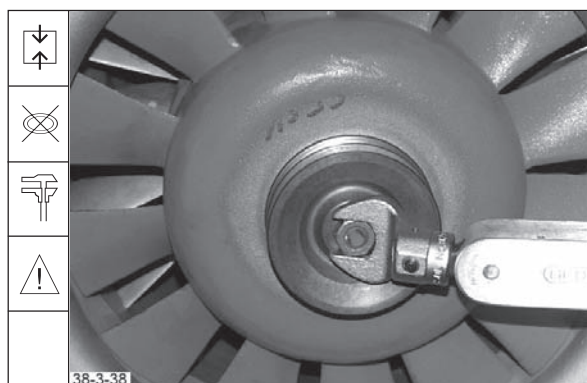

18. Neue Dichtung auflegen.



19. Deckel anbauen. Schrauben mit einem Drehmoment von **9 Nm** festdrehen.



**Bauteile instand setzen**  
**Repair of components**  
**Mise en état des composants**  
**Riparazione dei componenti**

---

**Massenausgleichswelle**  
**Mass balancing shaft**  
**Arbre à masses d'équilibrage**  
**Albero dell'equilibratore delle masse**

**Bauteile instandsetzen**  
**Repair of components**  
**Mise en état des composants**  
**Riparazione dei componenti**

---

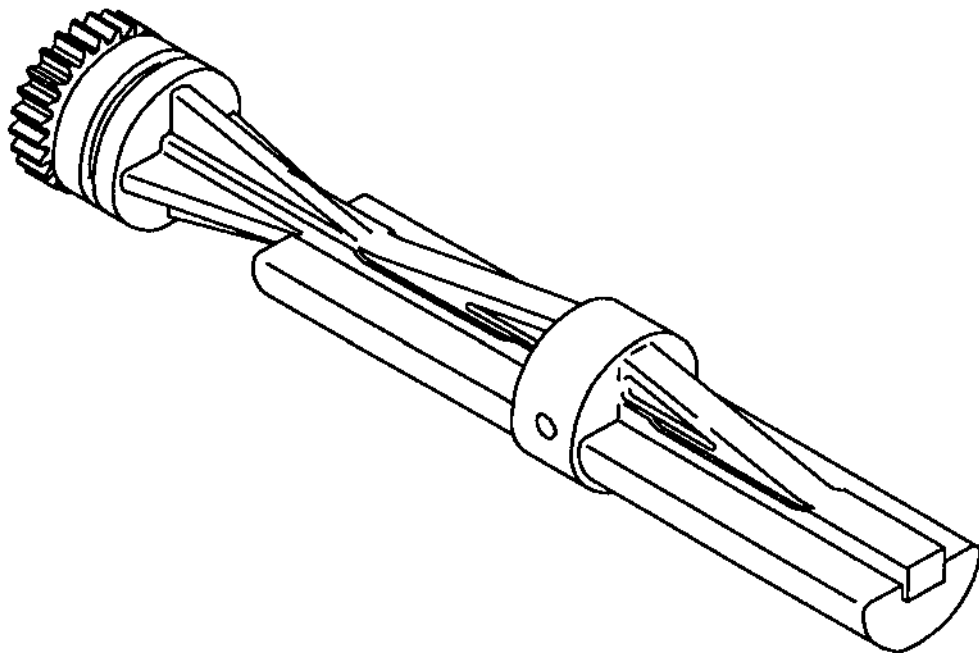

English	Français	Italiano
<b>BF4M 1012</b>	<b>BF4M 1012</b>	<b>BF4M 1012</b>
1. Inspect bearing journals for wear.	1. Contrôler visuellement l'usure du tourillon	1. Controllare l'eventuale usura dei perni di cuscinetto
2. Inspect gear for wear.	2. Contrôler visuellement l'usure du pignon	2. Controllare l'eventuale usura dell'ingranaggio

Deutsch

Werkstatthandbuch BFM 1012/E, BFM 1013/E

BF4M 1012

1. Lagerzapfen auf Verschleiß sichtprüfen.

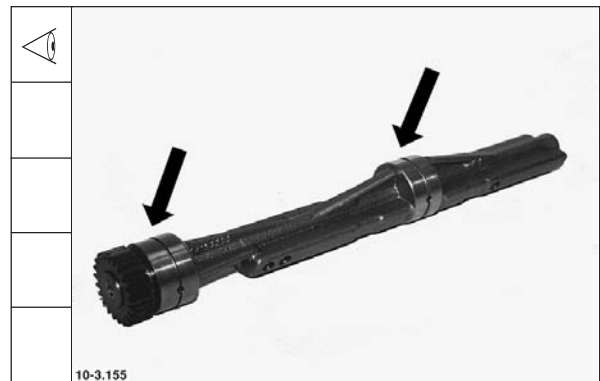

2. Zahnrad auf Verschleiß sichtprüfen.

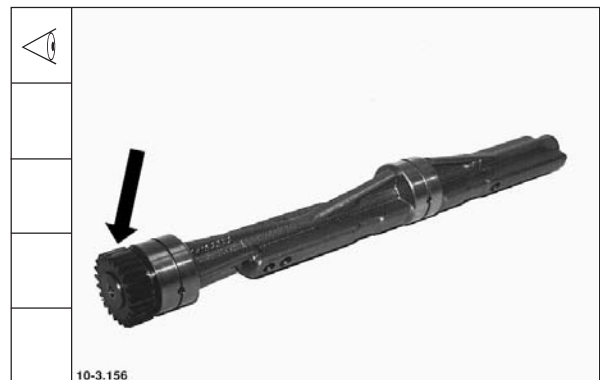

**Bauteile instand setzen**  
**Repair of components**  
**Mise en état des composants**  
**Riparazione dei componenti**

---

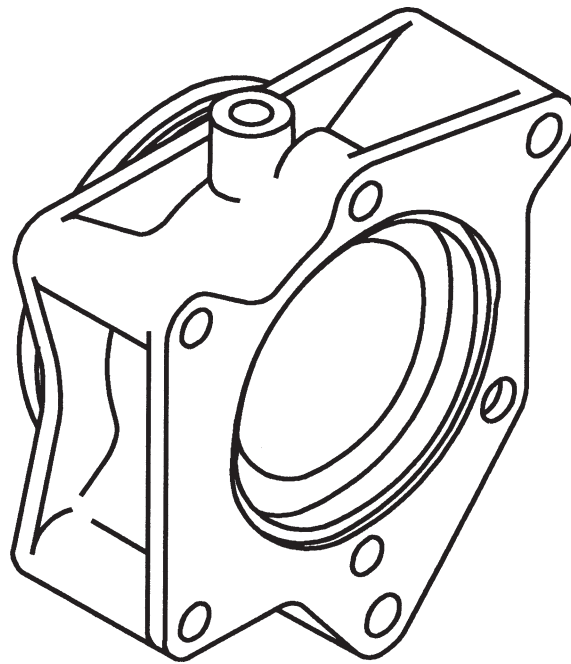

English	Français	Italiano
<p><b>Special tools required:</b></p> <p>Assembly tool for bearing bushes _____ 143 790            (Use assembly tool for BFM 1012 camshaft sleeves.)</p>	<p><b>Outillage spécial :</b></p> <p>Outil de montage pour bagues de palier _____ 143 790            (outil de montage pour bagues de paliers d'arbre à cames BFM 1012)</p>	<p><b>Attrezzi speciali:</b></p> <p>Attrezzo per montare le bronzine del cuscinetto ____ 143 790            (Utilizzare l'attrezzo per il montaggio delle bronzine del BFM 1012)</p>
<p>1. Remove stop washer.</p>	<p>1. Déposer rondelle de butée.</p>	<p>1. Smontare l'anello di arresto</p>
<p>2. Inspect all single parts and replace/repair if necessary.</p>	<p>2. Contrôler visuellement les pièces, au besoin les remplacer ou les remettre en état.</p>	<p>2. Controllare tutte le parti, sostituendole o riparandole qualora necessario.</p>
<p>3. Gauge bearing bushes at points „1“ and „2“ in planes „a“ and „b“.</p>	<p>3. Faire un relevé des cotes des bagues de palier aux points „1“ et „2“ aux plans „a“ et „b“.</p>	<p>3. Misurare le bronzine nei punti "1" e "2" sui piani "a" e "b".</p>
<p>Inner diameter: <b>60 + 0.054 mm</b>            Wear limit: <b>60 + 0.080 mm</b></p>	<p>Diamètre intérieur : <b>60 + 0,054 mm</b>            Usure limite : <b>60 + 0,080 mm</b></p>	<p>Diametro interno: <b>60 + 0,054 mm</b>            Limite d'usura: <b>60 + 0,080 mm</b></p>





Deutsch

Werkstatthandbuch BFM 1012/E, BFM 1013/E

Spezialwerkzeuge:

Montagewerkzeug für  
 Lagerbuchsen \_\_\_\_\_ 143 790  
 (Montagewerkzeug für Nockenwellen-  
 buchsen BFM 1012 verwenden.)

1. Anlaufscheibe abbauen.

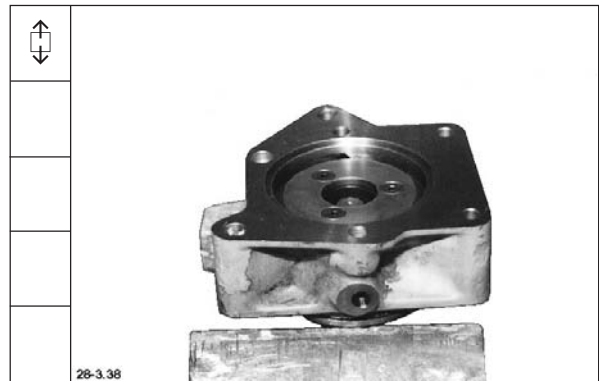

2. Alle Teile sichtprüfen, ggf. austauschen /  
 instand setzen.



3. Lagerbuchsen an den Punkten "1" und "2" in  
 der Ebene "a" und "b" messen.

Innendurchmesser: **60 + 0,054 mm**  
 Verschleißgrenze: **60 + 0,080 mm**

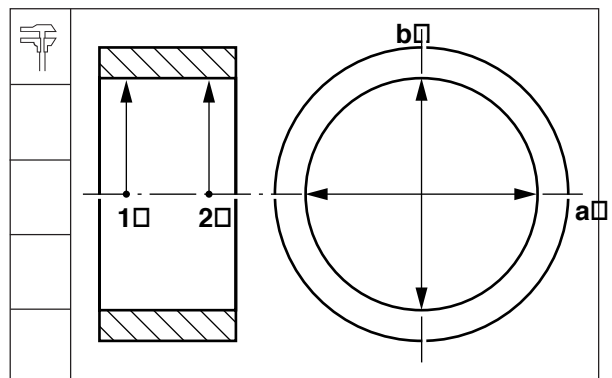

**Werkstatthandbuch BFM 1012/E, BFM 1013/E**

**Deutsch**

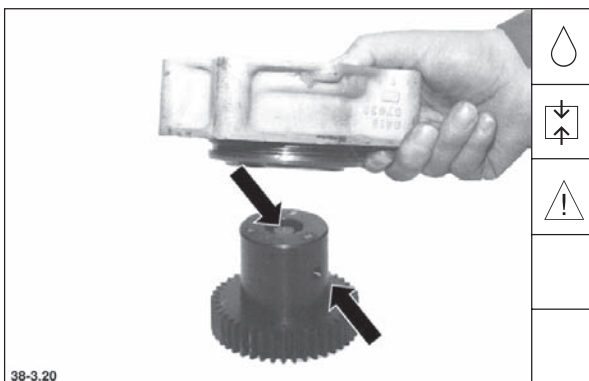
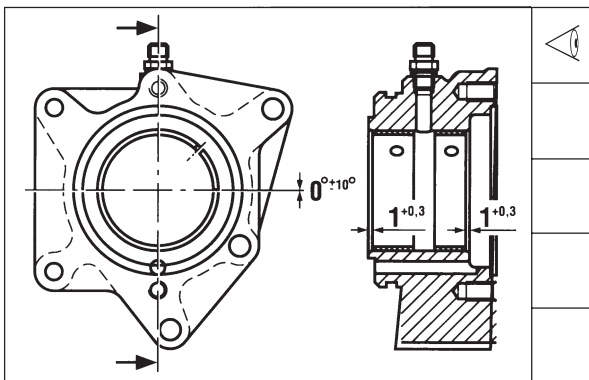

4. Bei Bedarf Buchsen auswechseln.

5. Schema: Einziehmaße und Einbaulage der Lagerbuchsen.

6. Lagerbuchsen nach Schema, Punkt 5, eindrücken.

7. Zahnradwelle und Buchsen mit Motoröl nach Klassifikation API-CC oder CCMC-D4 leicht einölen und montieren.

**Hinweis:** Bohrung in Hohl- und Mitnehmerwelle auf freien Durchgang prüfen.

English	Français	Italiano
4. Renew bushes if necessary.	4. Au besoin changer les bagues.	4. Sostituire le bronzine, se necessario.
5. Schematic: Installation dimensions and installation position of bearing bushes.	5. Schéma: cotes et emplacement de montage des bagues de palier.	5. Schema: misura della rientranza e disposizione delle bronzine montate.
6. Press in bearing bushes according to schematic, item 5.	6. Introduire les bagues de palier selon le schéma, point 5.	6. Montare le bronzine secondo lo schema al punto 5.
7. Lightly oil gear shaft and bushes with motor oil according to classification API-CC or CCMC-D4 and install.	7. Huiler légèrement l'arbre - pignon et les douilles en utilisant de l'huile moteur de la classification API-CC ou CCMC-D4.	7. Lubrificare leggermente l'ingranaggio e le bronzine con olio motore avente la classifica API-CC oppure CCMC-D4.
<b>Note:</b> Check bore in hollow shaft and drive shaft for free passage.	<b>Nota:</b> contrôler le libre passage de l'alésage de l'arbre creux et d'entraînement.	<b>Nota:</b> Controllare che il foro nell'albero cavo e nell'albero di comando sia libero.

English	Français	Italiano
8. Position stop washer in place.	8. Mettre en place la rondelle debutée.	8. Montare la rondella di arresto.
9. Tighten bolts with a torque of <b>8,5 ± 1 Nm.</b>	9. Serrer les vis au couple de <b>8,5 ± 1 Nm.</b>	9. Serrare le viti con una coppia di <b>8,5 ± 1.</b>
10. Fit new O-seal.	10. Monter un joint torique neuf.	10. Montare un nuovo O-Ring.

Deutsch

Werkstatthandbuch BFM 1012/E, BFM 1013/E

8. Anlaufscheibe auflegen.

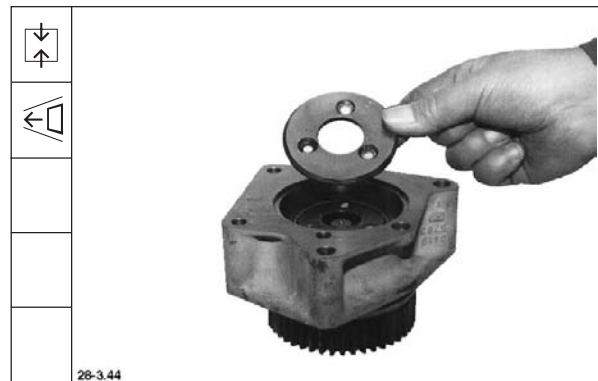

9. Schrauben mit einem Drehmoment von  $8,5 \pm 1$  Nm festdrehen.

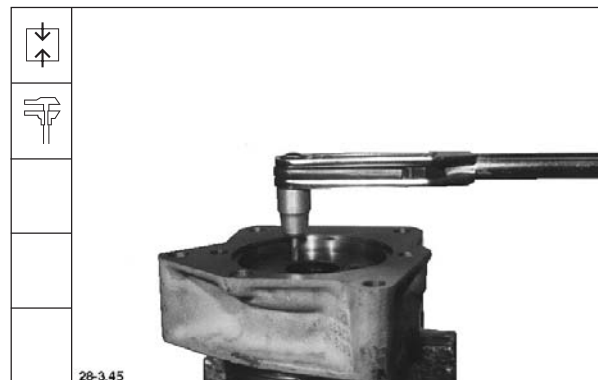

10. Neuen Runddichtring montieren.

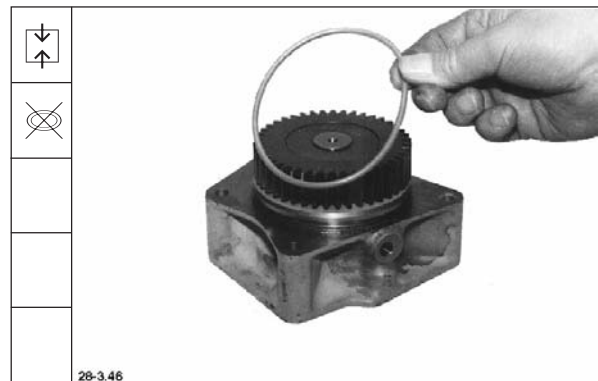

**English**

1. Remove gear.

2. Pull off gear.

3. Inspect all single parts and replace if necessary.

4. Fit new O-seal.

**Français**

1. Déposer le pignon.

2. Extraire le pignon.

3. Contrôler visuellement les pièces, au besoin les remplacer.

4. Monter un joint torique neuf.

**Italiano**

1. Svitare il dado di fermo della ruota dentata.

2. Estrarre la ruota dentata.

3. Controllare tutte le parti e sostituirle qualora necessario.

4. Montare un nuovo O-Ring.

Deutsch

Werkstatthandbuch BFM 1012/E, BFM 1013/E

1. Zahnrad abbauen.

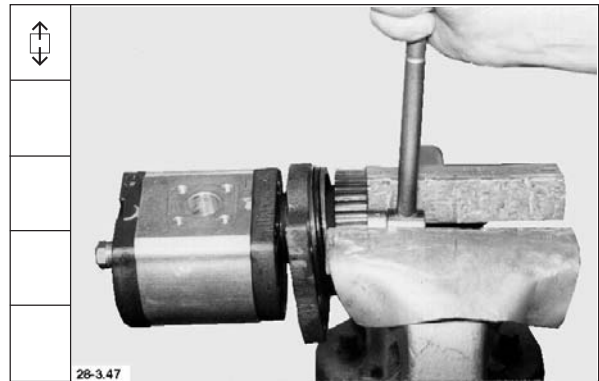

2. Zahnrad abziehen.

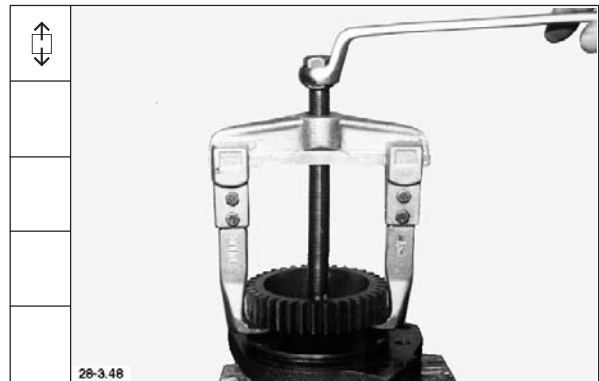

3. Alle Teile sichtprüfen, ggf. austauschen.



4. Neuen Runddichtring montieren.



**Bauteile instand setzen**  
**Repair of components**  
**Mise en état des composants**  
**Riparazione dei componenti**

---



**Hydraulikpumpe mit Befestigungsflansch**  
**Hydraulic pump with fastening flange**  
**Pompe hydraulique avec bride de fixation**  
**Pompa idraulica con flangia di fissaggio**

**Bauteile instandsetzen**  
**Repair of components**  
**Mise en état des composants**  
**Riparazione dei componenti**

---

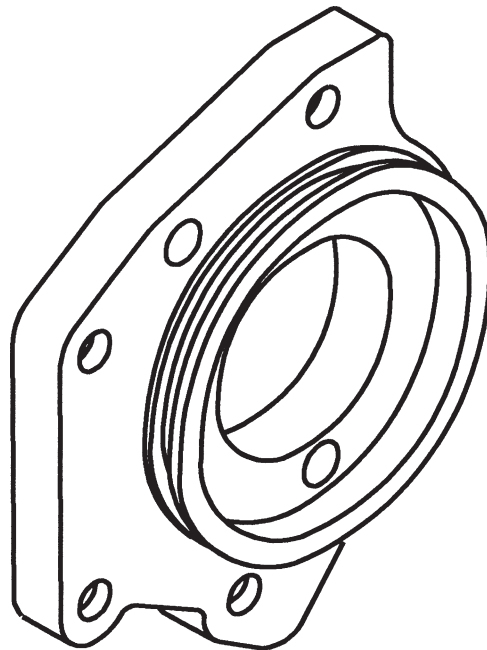

Werkstatthandbuch BFM 1012/E, BFM 1013/E

Deutsch

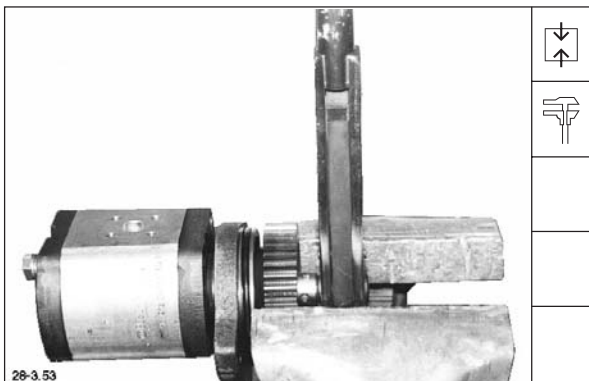

5. Neue Dichtung und Befestigungsflansch auf Hydraulikpumpe auflegen.

6. Zahnrad montieren.

**Hinweis:** Auf Vorhandensein der Paßfeder achten.

7. Mutter mit einem Drehmoment von **80 Nm** festdrehen.

English	Français	Italiano
5. Place new gasket together with fastening flange on hydraulic pump.	5. Placer un joint neuf et la bride de fixation sur la pompe hydraulique.	5. Montare sulla pompa idraulica la nuova guarnizione e la flangia d'attacco.
6. Mount gear. <b>Note:</b> Make sure that key is inserted.	6. Monter le pignon. <b>Nota:</b> veiller à la présence de la clavette.	6. Montare la ruota dentata. <b>Nota:</b> Controllare che ci sia la chiavetta.
7. Tighten nut with a torque of <b>80 Nm.</b>	7. Serrer l'écrou au couple de <b>80 Nm.</b>	7. Serrare il dado con una coppia di <b>80 Nm.</b>

**Bauteile instand setzen**  
**Repair of components**  
**Mise en état des composants**  
**Riparazione dei componenti**

---

**Demontage und Montage, Motor komplett**

**Disassembly and reassembly of complete engine**

**Démontage et montage moteur complet**

**Smontaggio e rimontaggio completo del motore**

# **BFM 1012/1013**





**Deutsch**

<b>4. Demontage und Montage, Motor komplett</b>	<b>Seite</b>
<b>Motor zerlegen</b>	4.00.01 - 4.00.16
<b>Motor zusammenbauen:</b>	
Ölspritzdüsen	4.00.17
Stößel/Nockenwelle	4.00.18
Kurbelwellenlagerung	4.00.18 - 4.00.21
Massenausgleichswellen BFM 1012	4.00.22 - 4.00.27
Antriebsrad/Regler	4.00.27
Regelstange	4.00.27 - 4.00.28
Räderkastendeckel	4.00.28 - 4.00.29
Vorderer Deckel	4.00.29 - 4.00.30
Kolben mit Pleuel	4.00.30 - 4.00.31
Einspritzpumpe einbauen	4.00.32 - 4.00.40
Schwungrad/Keilriemenscheibe	4.00.41
Zylinderkopf	4.00.42 - 4.00.47
Abstellmagnet	4.00.47
Einspritzventil/Einspritzleitungen	4.00.48 - 4.00.49
Luftansaugrohr/Abgassammelrohr	4.00.49 - 4.00.50
Zylinderkopfhäube	4.00.50 - 4.00.51
Schmierölkühler	4.00.51 - 4.00.52
Kühlmittelpumpe	4.00.52 - 4.00.54
Kraftstoffpumpe	4.00.54
Ölsaugrohr/Ölwanne	4.00.54 - 4.00.56
Regler	4.00.57 - 4.00.58
Kabelbaum	4.00.59
Anschlußgehäuse	4.00.60
Starter	4.00.61
Entlüftungsleitung	4.00.61 - 4.00.62
Öldruckschalter	4.00.62 - 4.00.63
Kurbelgehäuseentlüftung	4.00.63
Abgasturbolader	4.00.64 - 4.00.65
Ölrücklaufrohr/Druckölleitung	4.00.65 - 4.00.68
Ansaugkrümmer	4.00.68 - 4.00.70
Ladeluftkrümmer BFM 1013	4.00.70 - 4.00.71
Ölmeßstab	4.00.71
Generator	4.00.72
Keilriemen spannen	4.00.72 - 4.00.74
Motoraufhängung/Aufstellfüße	4.00.74
<b>Bauteile für integrierte Kühlung ab- und anbauen BFM 1012:</b>	
Bauteile abbauen	4.00.75 - 4.00.82
Bauteile anbauen	4.00.83 - 4.00.94
<b>Austausch der Wellendichtringe am kompletten Motor:</b>	
Räderkastendeckel Schwungradseite	4.00.95 - 4.00.96
Vorderer Deckel	4.00.96 - 4.00.97
<b>Nebenabtriebe ab- und anbauen:</b>	
Luftpresser ab- und anbauen	4.00.99 - 4.00.100
Lenkhilfspumpe ab- und anbauen	4.00.101 - 4.00.102
Hydraulikpumpe ab- und anbauen	4.00.103
Hydraulikpumpe mit Konsole ab- und anbauen	4.00.105 - 4.00.107
<b>Austausch der Einspritzpumpen im Servicefall</b>	4.00.109 - 4.00.112

**Werkstatthandbuch BFM 1012/E, BFM 1013/E**

**English**

<b>4. Disassembly and reassembly of complete engine</b>	<b>Page</b>
<b>Dismantling engine</b> _____	4.00.01 - 4.00.16
<b>Reassembling engine:</b>	
Oil spray nozzles _____	4.00.17
Tappets/camshaft _____	4.00.18
Crankshaft bearings _____	4.00.18 - 4.00.21
Mass balancing shafts BFM 1012 _____	4.00.22 - 4.00.27
Drive gear/governor _____	4.00.27
Control rod _____	4.00.27 - 4.00.28
Timing chest cover _____	4.00.28 - 4.00.29
Front cover _____	4.00.29 - 4.00.30
Piston with connecting rod _____	4.00.30 - 4.00.31
Installing injection pump _____	4.00.32 - 4.00.40
Flywheel/V-belt pulley _____	4.00.41
Cylinder head _____	4.00.42 - 4.00.47
Shutdown solenoid _____	4.00.47
Injector/injection lines _____	4.00.48 - 4.00.49
Air intake/exhaust manifold _____	4.00.49 - 4.00.50
Cylinder head cover _____	4.00.50 - 4.00.51
Lube oil cooler _____	4.00.51 - 4.00.52
Coolant pump _____	4.00.52 - 4.00.54
Fuel pump _____	4.00.54
Oil suction pipe/oil pan _____	4.00.54 - 4.00.56
Governor _____	4.00.57 - 4.00.58
Cable harness _____	4.00.59
Adapter housing _____	4.00.60
Starter _____	4.00.61
Breather pipe _____	4.00.61 - 4.00.62
Oil pressure switch _____	4.00.62 - 4.00.63
Crankcase breather _____	4.00.63
Exhaust turbocharger _____	4.00.64 - 4.00.65
Oil return pipe/pressure oil pipe _____	4.00.65 - 4.00.68
Intake elbow _____	4.00.68 - 4.00.70
Charge air elbow BFM 1013 _____	4.00.70 - 4.00.71
Oil dipstick _____	4.00.71
Alternator _____	4.00.72
Tensioning V-belt _____	4.00.72 - 4.00.74
Engine mounting/mounting feet _____	4.00.74
 <b>Removing and refitting components for integrated cooling system, BFM 1012:</b>	
Removing components _____	4.00.75 - 4.00.82
Refitting components _____	4.00.83 - 4.00.94
 <b>Replacing shaft seals on complete engine</b>	
Timing chest cover flywheel end _____	4.00.95 - 4.00.96
Front cover _____	4.00.96 - 4.00.97
 <b>Removing and refitting PTOs:</b>	
Removing and refitting air compressor _____	4.00.99 - 4.00.100
Removing and refitting power steering pump _____	4.00.101 - 4.00.102
Removing and refitting hydraulic pump _____	4.00.103
Removing and refitting hydraulic pump together with bracket _____	4.00.105 - 4.00.107
 <b>Replacing injection pumps in case of service</b> _____	4.00.109 - 4.00.112



**Français**

<b>4. Démontage et montage moteur complet</b>	<b>Page</b>
<b>Démontage du moteur</b> _____	4.00.01 - 4.00.16
<b>Montage du moteur:</b>	
Injecteurs _____	4.00.17
Poussoir/arbre à cames _____	4.00.18
Logement du vilebrequin _____	4.00.18 - 4.00.21
Arbre à masses d'équilibrage BFM 1012 _____	4.00.22 - 4.00.27
Pignon d'entraînement / régulateur _____	4.00.27
Crémaillère _____	4.00.27 - 4.00.28
Couvercle de carter de distribution _____	4.00.28 - 4.00.29
Couvercle avant _____	4.00.29 - 4.00.30
Piston-bielle _____	4.00.30 - 4.00.31
Montage de la pompe d'injection _____	4.00.32 - 4.00.40
Volant-moteur / poulie à gorge _____	4.00.41
Culasse _____	4.00.42 - 4.00.47
l'électroaimant d'arrêt _____	4.00.47
Injecteur / tuyauteries d'injection _____	4.00.48 - 4.00.49
Collecteur d'admission / collecteur d'échappement _____	4.00.49 - 4.00.50
Cache-culbuteurs _____	4.00.50 - 4.00.51
Radiateur à huile _____	4.00.51 - 4.00.52
Pompe à eau _____	4.00.52 - 4.00.54
Pompe à combustible _____	4.00.54
Tube d'aspiration d'huile / carter d'huile _____	4.00.54 - 4.00.56
Régulateur _____	4.00.57 - 4.00.58
Faisceau de câbles _____	4.00.59
Carter d'adaptation _____	4.00.60
Démarrreur _____	4.00.61
Conduite de dégazage _____	4.00.61 - 4.00.62
Manocontact de pression d'huile _____	4.00.62 - 4.00.63
Event de carter _____	4.00.63
Turbocompresseur _____	4.00.64 - 4.00.65
Tube de retour d'huile / tube de refoulement d'huile _____	4.00.65 - 4.00.68
Tubulure d'aspiration _____	4.00.68 - 4.00.70
Tubulure d'air de sualimentation BFM 1013 _____	4.00.70 - 4.00.71
Jauge d'huile _____	4.00.71
Alternateur _____	4.00.72
Tension de la courroie _____	4.00.72 - 4.00.74
Suspension moteur/pieds _____	4.00.74
<b>Démontage et montage des composants du refroidissement intégré BFM 1012:</b>	
Démontage des composants _____	4.00.75 - 4.00.82
Montage des composants _____	4.00.83 - 4.00.94
<b>Changement des joints d'arbre sur moteur complet :</b>	
Couvercle de carter de distribution côté volant moteur _____	4.00.95 - 4.00.96
Couvercle AV _____	4.00.96 - 4.00.97
<b>Montage et démontage des équipements auxiliaires :</b>	
Montage et démontage compresseur _____	4.00.99 - 4.00.100
Montage et démontage pompe auxiliaire de direction _____	4.00.101 - 4.00.102
Montage et démontage pompe hydraulique _____	4.00.103
Montage et démontage pompe hydraulique avec console _____	4.00.105 - 4.00.107
<b>Changement de pompes d'injection en SAV _____</b>	<b>4.00.109 - 4.00.112</b>

**Werkstatthandbuch BFM 1012/E, BFM 1013/E**

**Italiano**

**4. Smontaggio e rimontaggio completo del motore**

**Pagina**

**Smontaggio del motore** \_\_\_\_\_ 4.00.01 - 4.00.16

**Rimontaggio del motore:**

Spruzzatori d'olio \_\_\_\_\_ 4.00.17

Punterie/Albero a camme \_\_\_\_\_ 4.00.18

Cuscinetti di banco \_\_\_\_\_ 4.00.18 - 4.00.21

Albero di equilibratura delle masse BFM 1012 \_\_\_\_\_ 4.00.22 - 4.00.27

Ingranaggio di comando/Regolatore \_\_\_\_\_ 4.00.27

Asta a cremagliera \_\_\_\_\_ 4.00.27 - 4.00.28

Coperchio della scatola della distribuzione \_\_\_\_\_ 4.00.28 - 4.00.29

Coperchio anteriore \_\_\_\_\_ 4.00.29 - 4.00.30

Pistone con biella \_\_\_\_\_ 4.00.30 - 4.00.31

Montaggio della pompa d'iniezione \_\_\_\_\_ 4.00.32 - 4.00.40

Volano/Puleggia della cinghia trapezoidale \_\_\_\_\_ 4.00.41

Testa cilindri \_\_\_\_\_ 4.00.42 - 4.00.47

Elettromagnete d'arresto \_\_\_\_\_ 4.00.47

Iniettore/Tubazioni d'iniezione \_\_\_\_\_ 4.00.48 - 4.00.49

Collettore d'aspirazione/Collettore di scarico \_\_\_\_\_ 4.00.49 - 4.00.50

Coperchio delle punterie \_\_\_\_\_ 4.00.50 - 4.00.51

Refrigeratore dell'olio lubrificante \_\_\_\_\_ 4.00.51 - 4.00.52

Pompa del mezzo refrigerante \_\_\_\_\_ 4.00.52 - 4.00.54

Pompa del combustibile \_\_\_\_\_ 4.00.54

Tubazione d'aspirazione dell'olio/ Coppa dell'olio \_\_\_\_\_ 4.00.54 - 4.00.56

Regolatore dei giri del motore \_\_\_\_\_ 4.00.57 - 4.00.58

Cablaggio preassemblato \_\_\_\_\_ 4.00.59

Campana di collegamento \_\_\_\_\_ 4.00.60

Motorino d'avviamento \_\_\_\_\_ 4.00.61

Tubazione di sfianto \_\_\_\_\_ 4.00.61 - 4.00.62

Interruttore pressostatico dell'olio \_\_\_\_\_ 4.00.62 - 4.00.63

Sfiato dell'incastellatura del motore \_\_\_\_\_ 4.00.63

Turbina di sovralimentazione \_\_\_\_\_ 4.00.64 - 4.00.65

Tubazione di ritorno dell'olio/Tubazione di mandata dell'olio \_\_\_\_\_ 4.00.65 - 4.00.68

Curva d'aspirazione \_\_\_\_\_ 4.00.68 - 4.00.70

Curva d'aspirazione aria di sovralimentazione BFM 1013 \_\_\_\_\_ 4.00.70 - 4.00.71

Astina di misurazione del livello dell'olio \_\_\_\_\_ 4.00.71

Generatore \_\_\_\_\_ 4.00.72

Tesatura della cinghia trapezoidale \_\_\_\_\_ 4.00.72 - 4.00.74

Sospensioni del motore/Piedini di supporto \_\_\_\_\_ 4.00.74

**Smontaggio e rimontaggio dei componenti del sistema di raffreddamento integrato BFM 1012:**

Smontaggio dei componenti \_\_\_\_\_ 4.00.75 - 4.00.82

Rimontaggio dei componenti \_\_\_\_\_ 4.00.83 - 4.00.94

**Sostituzione degli anelli paraolio sul motore completo:**

Coperchio della scatola della distribuzione sul lato volano \_\_\_\_\_ 4.00.95 - 4.00.96

Coperchio anteriore \_\_\_\_\_ 4.00.96 - 4.00.97

**Smontaggio e rimontaggio di prese di forza:**

Smontaggio e rimontaggio del compressore dell'aria \_\_\_\_\_ 4.00.99 - 4.00.100

Smontaggio e rimontaggio della pompa per il servosterzo \_\_\_\_\_ 4.00.101 - 4.00.102

Smontaggio e rimontaggio della pompa idraulica \_\_\_\_\_ 4.00.103

Smontaggio e rimontaggio della pompa idraulica completa di mensola \_\_\_\_\_ 4.00.105 - 4.00.107

**Sostituzione delle pompe d'iniezione nel caso di Service** \_\_\_\_\_ 4.00.109 - 4.00.112

**Demontage und Montage, Motor komplett**  
**Disassembly and reassembly of complete engine**  
**Démontage et montage moteur complet**  
**Smontaggio e rimontaggio completo del motore**

---

**Demontage und Montage, Motor komplett**  
**Disassembly and reassembly of complete engine**  
**Démontage et montage moteur complet**  
**Smontaggio e rimontaggio completo del motore**

English	Français	Italiano
<b>Dismantling engine</b>	<b>Démontage du moteur</b>	<b>Smontaggio del motore</b>
<b>Commercial tools required:</b>	<b>Outillage usuel :</b>	<b>Attrezzi normali</b>
Torx tool kit _____ 8189	Jeu d'outils Torx _____ 8189	Kit di attrezzi TORX _____ 8189
Torx socket wrench E 14 _____ 8113	Clé à douilles Torx E 14 _____ 8113	Chiave a tubi Torx E 14 _____ 8113
Torx socket wrench E 18 _____ 8116	Clé à douilles Torx E 18 _____ 8116	Chiave a tubi Torx E 18 _____ 8116
Torx socket wrench E 20 _____ 8114	Clé à douilles Torx E 20 _____ 8114	Chiave a tubi Torx E 20 _____ 8114
Spring clamp pliers _____ 9090	Pince de serrage pour ressorts _ 9090	Pinza bloccaggio molla _____ 9090
Spring clamp pliers _____ 9088	Pince de serrage pour ressorts _ 9088	Pinza bloccaggio molla _____ 9088
Auxiliary tool for glow plug cable coupler _____ 9115	Outil pour accouplement de câble de bougie de préchauffage _____ 9115	Attrezzo ausiliario per il giunto del cavo delle candele _____ 9115
Cobra clamp pliers _____ 8011	Pince de serrage Cobra _____ 8011	Pinza di bloccaggio Cobra _____ 8011
<b>Special tools required:</b>	<b>Outillage spécial:</b>	<b>Attrezzi speciali:</b>
Engine assembly stand BFM 1012 _____ 6067	Chevalet de montage de moteur BFM 1012 _____ 6067	Cavalletto di montaggio per i motori: BFM 12 _____ 6067
BFM 1013 _____ 6066	BFM 1013 _____ 6066	BFM 13 _____ 6066
Angled clamping plate BFM 1012 for external cooling system ____ 6067/118	Support d'ablocage BFM 1012 pour refroidissement externe ____ 6067/118	Supporto per BFM 1012 con raffredd. esterno ____ 6067/118
Angled clamping plate BFM 1012 for integrated cooling system _ 6067/119	Support d'ablocage BFM 1012 pour refroidissement intégré ____ 6067/119	Supporto per BFM 1012 con raffredd. integrato ____ 6067/119
Angled clamping plate BFM 1013 _____ 6066/158	Equerre d'ablocage BFM 1013 _____ 6066/158	Angolari per BFM 1013 ____ 6966/158
Extractor for injector _____ 110 030	Extracteur d'injecteur _____ 110 030	Estrattore per gli iniettori ____ 110 030
Special device for extractor _____ 150 800	Dispositif spécial d'extracteur _____ 150 800	Dispositivo speciale per: dispositivo d'estrazione ____ 150 800
filter cartridges _____ 170 050	Cartouches de filtre _____ 170 050	cartucce del filtro _____ 170 050
The repair procedure outlined in this chapter refers to the standard specification, i.e. components for customizing the engine are not shown.	Les travaux de réparation indiqués ne tiennent pas compte de la diversité des volumes de livraison des clients, c'est- à-dire que les pièces annexes différentes du modèle standard ne sont pas présentées dans le présent Manuel.	Nella sequenza di riparazione descritta non si tiene conto delle diverse entità di fornitura dei clienti, vale a dire che i componenti con compresi nella esecu- zione standard non vengono illustrati.
1. Mount angled clamping plate.  Illustration shows BFM 1012.	1. Monter le dispositif d'ablocage.  Illustration BFM 1012	1. Montare il supporto.  Raffigurato il BFM 1012.
<b>BFM 1012</b>	<b>BFM 1012</b>	<b>BFM 1012</b>
2. Clamp engine in swivelling assembly stand and align. Tighten bolts.	2. Aligner le moteur sur le chevalet de montage pivotable.	2. Montare il motore sul cavalletto orientabile. Serrare bene le viti.
<b>Drain and catch remaining oil and coolant and dispose of in accordance with anti- pollution regulations.</b>	<b>Vidanger les restes d'huile ou de réfrigérant et les récupérer selon la réglementation antipollution.</b>	<b>Scaricare l'olio ed il mezzo refrigerante, recuperarli negli appositi contenitori e smaltirli secondo le prescrizioni relative al rispetto dell'ambiente.</b>

**Deutsch**

**Werkstatthandbuch BFM 1012/E, BFM 1013/E**

**Motor zerlegen**

**Handelsübliche Werkzeuge:**

Torx-Werkzeugsatz _____	8189
Torx-Steckschlüssel E14 _____	8113
Torx-Steckschlüssel E18 _____	8116
Torx-Steckschlüssel E20 _____	8114
Federklemmenzange _____	9090
Federklemmenzange _____	9088
Hilfswerkzeug für Glühkerzen- Kabelkupplung _____	9115
Cobraklemmenzange _____	8011

**Spezialwerkzeuge:**

Motor-Montagebock BFM 1012 _____	6067
BFM 1013 _____	6066
Aufspannhalter BFM 1012 für externe Kühlung _____	6067/118
Aufspannhalter BFM 1012 für integrierte Kühlung _____	6067/119
Aufspannwinkel BFM 1013 _____	6066/158
Auszieher für Einspritzventil _____	110 030
Spezialvorrichtung für Ausziehvorrichtung _____	150 800
Filterpatronen _____	170 050

Bei dem gezeigten Reparaturablauf sind unterschiedliche Kundenumfänge nicht berücksichtigt, d.h., von der Standard-Ausführung abweichende Anbauteile werden nicht gezeigt.

1. Aufspannhalter anbauen.

Darstellung BFM 1012.

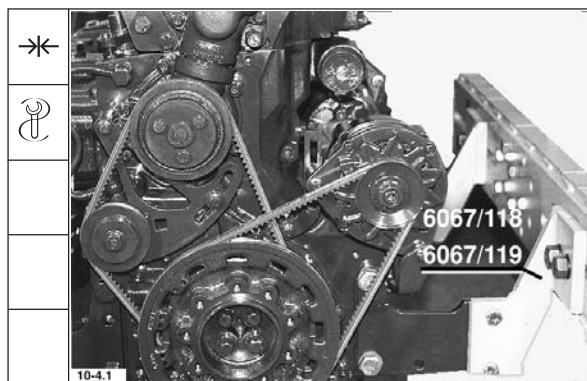

**BFM 1012**

2. Motor im schwenkbaren Montageblock ausrichten. Schrauben festdrehen.  
**Öl bzw. Restöl und Kühlmittel ablassen, auffangen und vorschriftsmäßig entsorgen.**

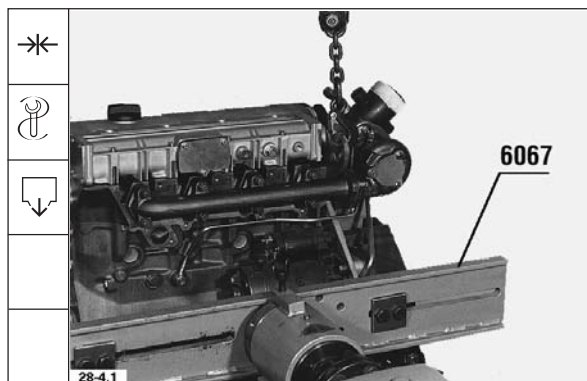

**Demontage und Montage, Motor komplett**  
**Disassembly and reassembly of complete engine**  
**Démontage et montage moteur complet**  
**Smontaggio e rimontaggio completo del motore**

Werkstatthandbuch BFM 1012/E, BFM 1013/E

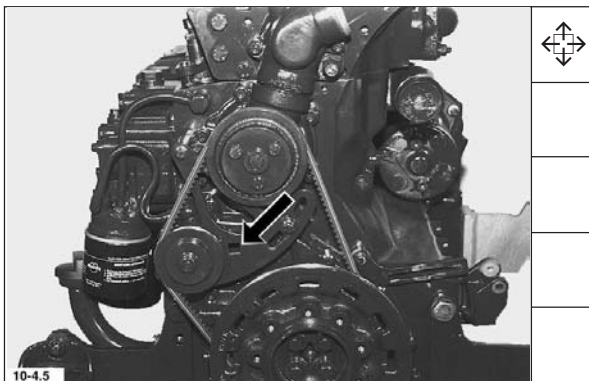
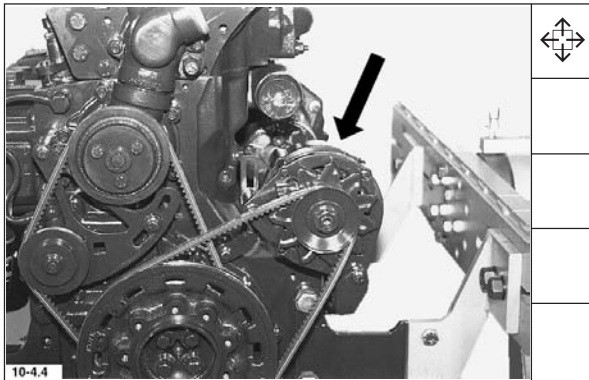
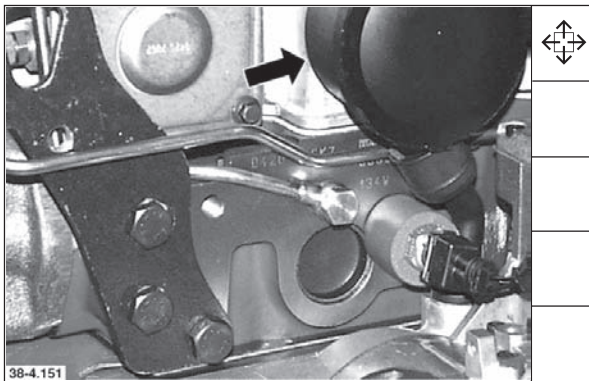
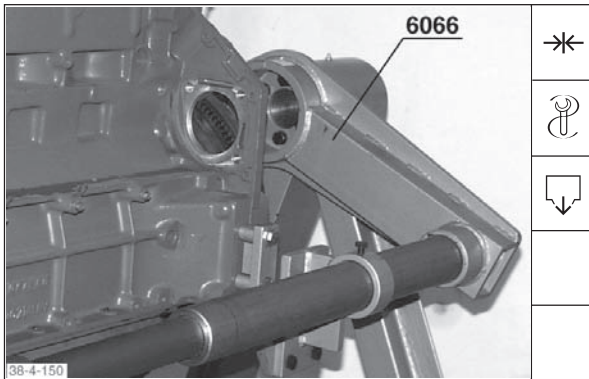

Deutsch

**BFM 1013**

2.1 Motor in doppelseitigen schwenkbaren Montagebock aufnehmen und ausrichten. Schrauben festdrehen.

**Öl bzw. Restöl und Kühlmittel ablassen, auffangen und vorschriftsmäßig entsorgen.**

Bei Teildemontage und Drehen des Motors um 180° ist das **Druckregelventil zu entfernen. Restöl und Kühlmittel auffangen und vorschriftsmäßig entsorgen.**

3. Generator abbauen.

4. Kraftstoffpumpe lösen. Keilriemen abnehmen.

**Demontage und Montage, Motor komplett**  
**Disassembly and reassembly of complete engine**  
**Démontage et montage moteur complet**  
**Smontaggio e rimontaggio completo del motore**

English	Français	Italiano
<p><b>BFM 1013</b></p> <p>2.1 Clamp engine in double-sided swivelling assembly stand and align. Tighten bolts.</p> <p><b>Drain and catch remaining oil and coolant and dispose of in accordance with anti-pollution regulations.</b></p> <p>In case of parts assembly and turning of engine by 180° <b>the pressure control valve is to be removed.</b>  <b>Catch any remaining oil and coolant and dispose of in accordance with anti-pollution regulations.</b></p> <p>3. Remove alternator.</p> <p>4. Loosen fuel pump. Remove V-belt.</p>	<p><b>BFM 1013</b></p> <p>2.1 Monter puis aligner le moteur sur le double chevalet de montage. Bloquer les vis.</p> <p><b>Vidanger les restes d'huile ou de réfrigérant et les récupérer selon la réglementation antipollution.</b></p> <p>En cas de montage partiel et s'il faut virer le moteur de 180° <b>retirer la vanne de régulation de pression.</b>  <b>Récupérer l'huile restante et le liquide de refroidissement.</b></p> <p>3. Déposer l'alternateur.</p> <p>4. Desserrer la pompe à combustible. Retirer la courroie trapézoïdale.</p>	<p><b>BFM 1013</b></p> <p>2.1 Montare il motore sul cavalletto orientabile sui due lati ed allinearlo. Serrare le viti.</p> <p><b>Scaricare l'olio ed il mezzo refrigerante, recuperarli e smaltirli secondo le prescrizioni vigenti.</b></p> <p>Nel caso in cui si debba smontare parzialmente oppure ruotare il motore di 180°, <b>si deve smontare la valvola di regolazione della mandata.</b>  <b>I resti dell'olio ed il mezzo refrigerante devono venire recuperati e smaltiti secondo le prescrizioni vigenti.</b></p> <p>3. Smontare il generatore.</p> <p>4. Allentare le viti della pompa del combustibile e smontare la cinghia trapezoidale.</p>



**Demontage und Montage, Motor komplett**  
**Disassembly and reassembly of complete engine**  
**Démontage et montage moteur complet**  
**Smontaggio e rimontaggio completo del motore**

English	Français	Italiano
5. Remove bracket.	5. Déposer la console.	5. Smontare la mensola.
6. Remove coolant pipe.	6. Déposer le tube de liquide de refroidissement.	6. Smontare la tubazione del mezzo refrigerante.
7. Remove breather pipe using special spring clamp pliers.	7. Retirer le tube de purge avec une pince à crampon spéciale.	7. Smontare la tubazione di sfiato per mezzo dell'apposita pinza di bloccaggio molla.
8. Remove intake hose.	8. Déposer le flexible d'aspiration.	8. Smontare il tubo flessibile di aspirazione.
<b>Note:</b> Cover up opening of exhaust turbo charger.	<b>Nota:</b> boucher orifice du turbocompresseur.	<b>Nota:</b> Tappare l'apertura del turbocompressore.



Deutsch

Werkstatthandbuch BFM 1012/E, BFM 1013/E

5. Konsole abbauen.

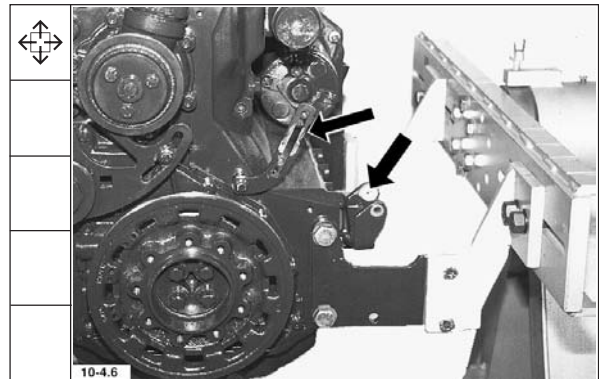

6. Kühlmittelrohr abbauen.

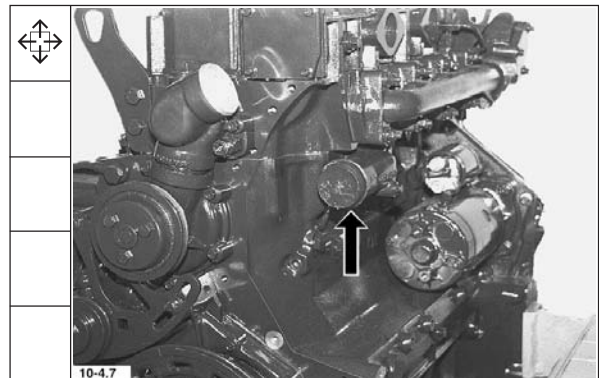

7. Entlüftungsleitung mit spez. Federklemmenzange abbauen.

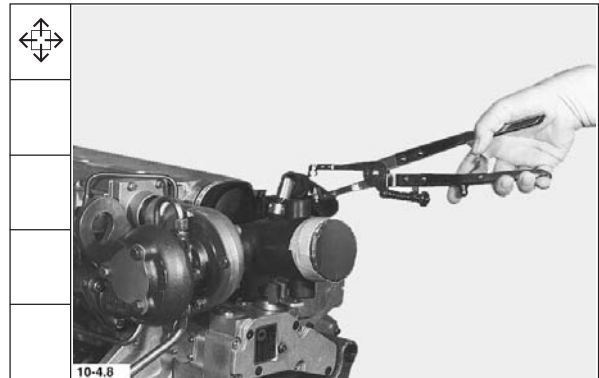

8. Ansaugschlauch abbauen.

**Hinweis:** Öffnung von Abgasturbolader verschließen.

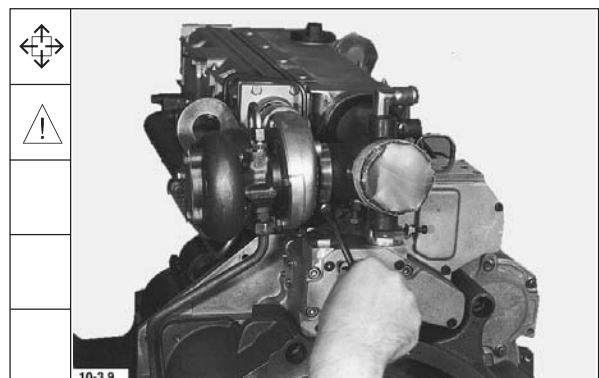

**Demontage und Montage, Motor komplett**  
**Disassembly and reassembly of complete engine**  
**Démontage et montage moteur complet**  
**Smontaggio e rimontaggio completo del motore**

**Werkstatthandbuch BFM 1012/E, BFM 1013/E**

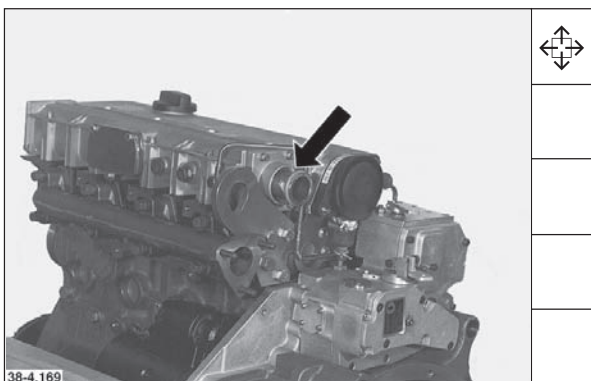
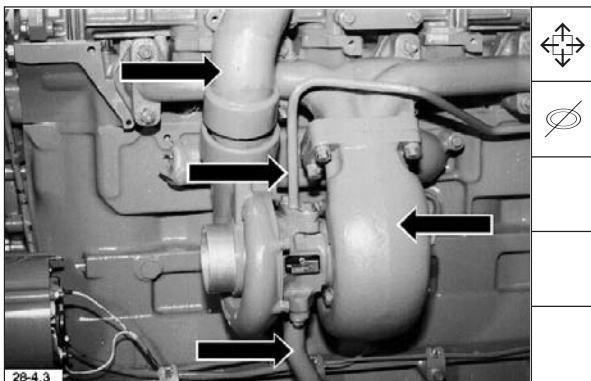
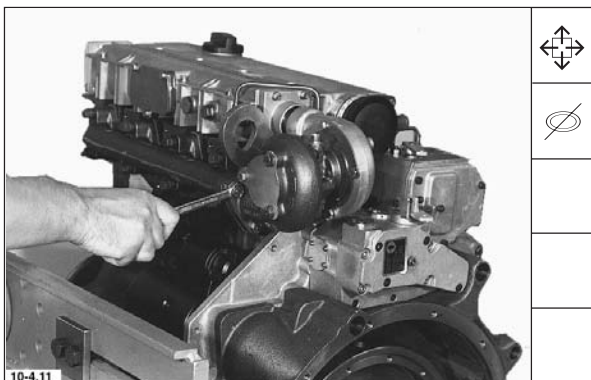
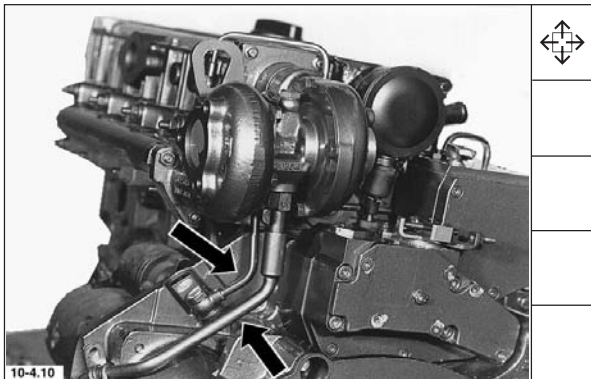

**Deutsch**

9. Öldruckleitung und Ölrücklaufleitung BFM 1012 abbauen.

10. Abgasturbolader BFM 1012 abbauen. Schadhaften Abgasturbolader austauschen.

10.1 Öldruckleitung, Ölrücklaufleitung, Ladeluftkrümmer und Abgasturbolader BFM 1013 abbauen. Schadhaften Abgasturbolader austauschen.

11. Steckstück herausziehen.

**Demontage und Montage, Motor komplett**  
**Disassembly and reassembly of complete engine**  
**Démontage et montage moteur complet**  
**Smontaggio e rimontaggio completo del motore**

English	Français	Italiano
9. Remove BFM 1012 oil pressure pipe and oil return pipe.	9. Déposer la conduite de pression d'huile du BFM 1012.	9. Smontare la tubazione di mandata dell'olio e la tubazione di ritorno di ritorno dell'olio del BFM 1012.
10. Remove BFM 1012 exhaust turbocharger. Replace damaged turbocharger.	10. Déposer le turbocompresseur du BFM 1012. Remplacer le turbocompresseur endommagé.	10. Smontare il turbocompressore del BFM 1012. Un turbocompressore danneggiato deve venire sostituito.
10.1 Remove BFM 1013 oil pressure pipe, oil return pipe, charge air elbow and exhaust turbocharger. Replace damaged turbocharger.	10.1 Déposer la conduite de refoulement d'huile, la conduite de retour d'huile, la tubulure d'air de suralimentation et le turbocompresseur d'échappement du BFM 1013. Remplacer tout turbocompresseur endommagé.	11. Smontare la tubazione di mandata dell'olio, la tubazione di ritorno dell'olio, la curva dell'aria di sovralimentazione ed il turbocompressore del BFM 1013. Un turbocompressore danneggiato deve venire sostituito.
11. Pull out plug-in element	11. Retirer l'élément enfichable.	12. Estrarre il perno ad innesto.

**Demontage und Montage, Motor komplett**  
**Disassembly and reassembly of complete engine**  
**Démontage et montage moteur complet**  
**Smontaggio e rimontaggio completo del motore**

English	Français	Italiano
12. Remove pressure control valve together with hose.	12. Déposer la vanne de régulation de pression et le flexible.	12. Smontare la valvola di regolazione della pressione e relativa tubazione.
13. Remove air pipe to manifold pressure compensator (LDA) and breather pipe.	13. Déposer la conduite d'air du correcteur de débit (LDA) et la conduite de purge.	13. Smontare la condotta d'aria al correttore di mandata (LDA), nonché la tubazione di sfiato.
14. Remove starter.	14. Déposer le démarreur.	14. Smontare il motorino d'avviamento.
15. Remove lifting lugs.	15. Déposer les oeilletons de manutention.	15. Smontare gli occhioni di trasporto.

**Deutsch**

**Werkstatthandbuch BFM 1012/E, BFM 1013/E**

12. Druckregelventil mit Schlauch abbauen.

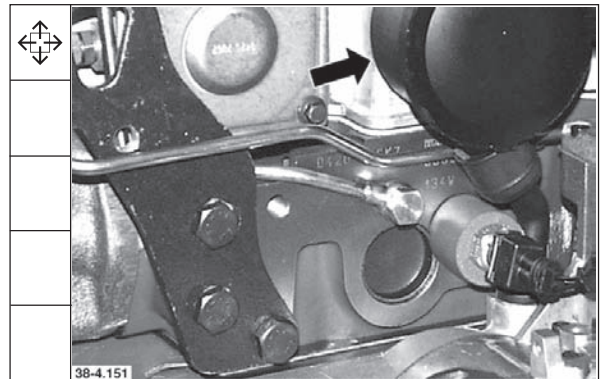

13. Luftleitung zum LDA und Entlüftungsleitung abbauen.

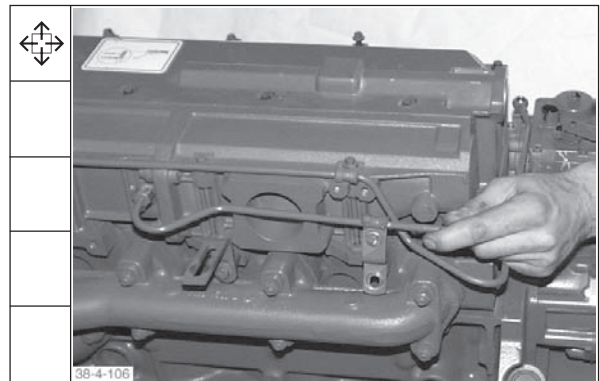

14. Starter abbauen.

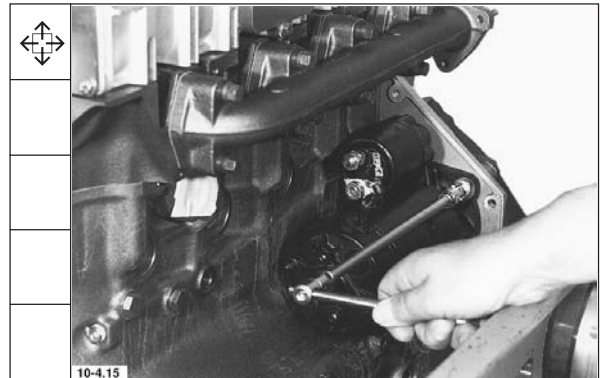

15. Transportösen abbauen.

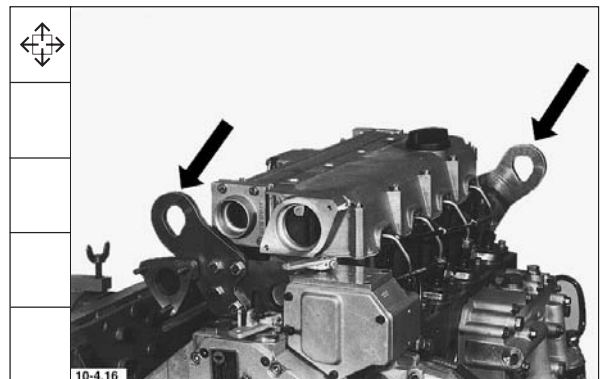

**Demontage und Montage, Motor komplett**  
**Disassembly and reassembly of complete engine**  
**Démontage et montage moteur complet**  
**Smontaggio e rimontaggio completo del motore**

Werkstatthandbuch BFM 1012/E, BFM 1013/E

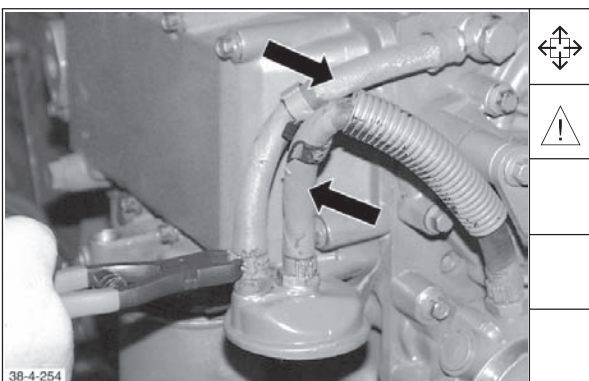
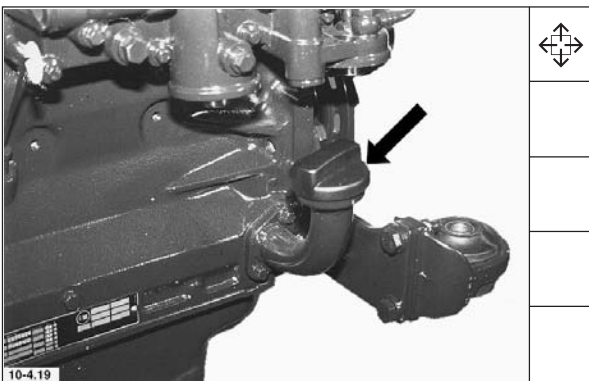
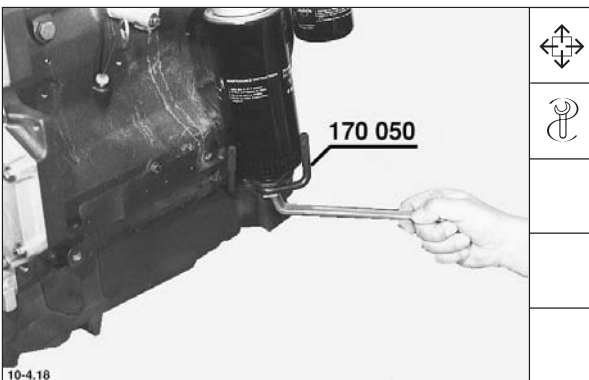
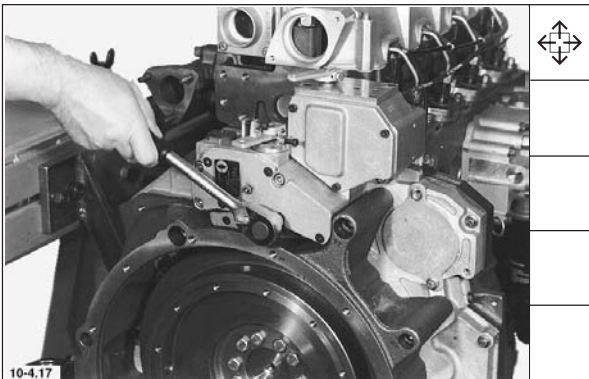

**Deutsch**

16. Drehzahlregler abbauen.

17. Kraftstoff-und Ölfilter mit Spezialvorrichtung abbauen.  
**Restöl und Kraftstoff vorschriftsmäßig entsorgen.**

18. Öleinfüllstutzen falls vorhanden abbauen.

19. Kraftstoffleitungen abbauen.

**Hinweis:** Cobraklemmenzange benutzen.



**Demontage und Montage, Motor komplett**  
**Disassembly and reassembly of complete engine**  
**Démontage et montage moteur complet**  
**Smontaggio e rimontaggio completo del motore**

English	Français	Italiano
16. Remove governor.	16. Déposer le régulateur de vitesse.	16. Smontare il regolatore di giri.
17. Remove fuel and oil filter using special device for filter cartridges. <b>Dispose of remaining oil and fuel in accordance with anti-pollution regulations.</b>	17. Déposer le filtre à combustible et le filtre à huile avec une pince spéciale. <b>Éliminer les restes d'huile ou de réfrigérant selon la réglementation antipollution.</b>	17. Servendosi del dispositivo speciale, smontare il filtro del combustibile ed il filtro dell'olio. <b>Smaltire i resti di olio e di combustibile secondo le prescrizioni vigenti.</b>
18. Remove oil filler neck if any.	18. Déposer la tubulure de remplissage si le moteur en est doté d'un.	18. Smontare, qualora esista, il bocchettone di rabbocco dell'olio
19. Remove fuel lines. <b>Note:</b> Use Cobra clamp pliers.	19. Déposer les tuyauteries de combustible. <b>Nota:</b> utiliser la pince de serrage Cobra.	19. Smontare le tubazioni del combustibile. <b>Nota:</b> Utilizzare la pinza di bloccaggio Cobra.

**Demontage und Montage, Motor komplett**  
**Disassembly and reassembly of complete engine**  
**Démontage et montage moteur complet**  
**Smontaggio e rimontaggio completo del motore**

English	Français	Italiano
20. Remove fuel pump with clamping plate.	20. Déposer la pompe à combustible avec la griffe de serrage.	20. Smontare la pompa del combustibile con relativo supporto.
21. Remove lube oil cooler. Remove also retainer for cable connector if any.	21. Déposer le radiateur à huile. Si le moteur en a un, déposer le collier de liaison des câbles.	21. Smontare il refrigeratore dell'olio lubrificante. Se esiste, smontare il supporto per il connettore dei cavi.
22. Remove coolant pump together with thermostat housing.	22. Déposer la pompe à réfrigérant avec le boîtier du thermostat.	22. Smontare la pompa del mezzo refrigerante assieme alla scatola del termostato.
23. Disconnect glow plug cable coupler if any. For such purpose introduce auxiliary tool carefully into rubber grommet without turning it in any way and disconnect cable.	23. Si le moteur en a un, désolidariser le coupleur de câbles des bougies de préchauffage. Pour ce faire introduire avec précaution l'outil auxiliaire dans la douille en caoutchouc sans tourner puis séparer le câble.	23. Se esiste, staccare la giuntura del cavo collegato alle candele di preriscaldamento. A questo scopo si deve introdurre nella boccola isolante l'attrezzo ausiliario con precauzione e senza ruotarlo, e quindi staccare il cavo.



**Deutsch**

**Werkstatthandbuch BFM 1012/E, BFM 1013/E**

20. Kraftstoffpumpe mit Spannlasche abbauen.

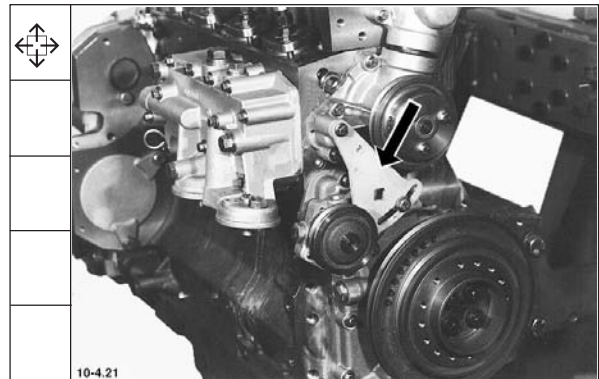

21. Schmierölkühler abbauen.  
Falls vorhanden, Halter für Kabelverbinder mit abbauen.

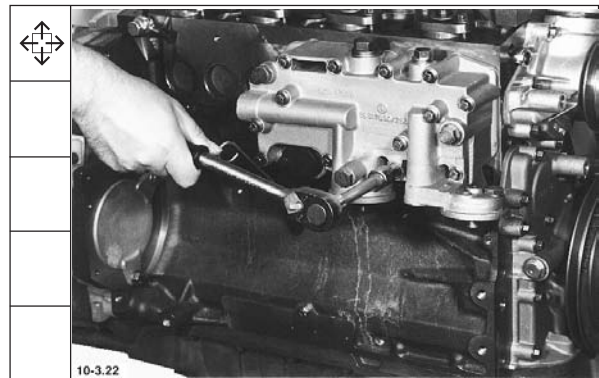

22. Kühlmittelpumpe mit Thermostatgehäuse abbauen.

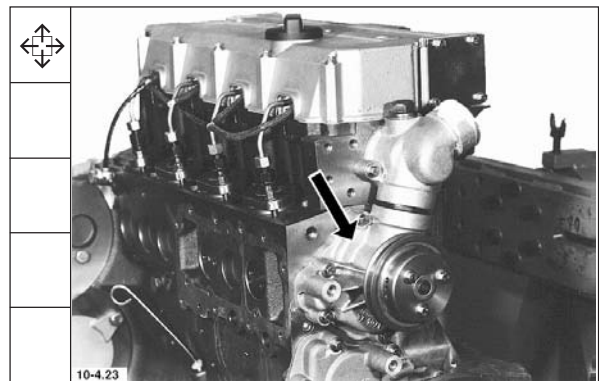

23. Falls vorhanden, Glühkerzen-Kabelkupplung trennen. Hierzu Hilfswerkzeug vorsichtig ohne Drehbewegung in die Gummitülle einführen und Kabel trennen.

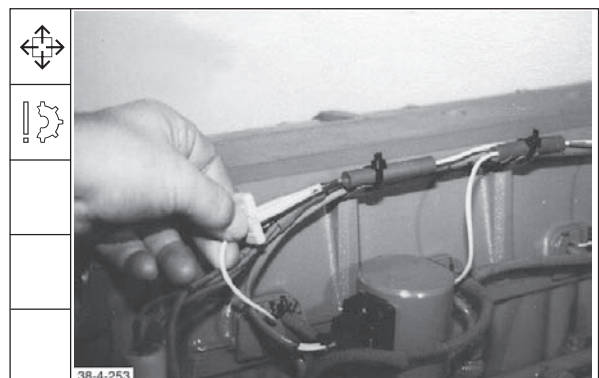

**Demontage und Montage, Motor komplett**  
**Disassembly and reassembly of complete engine**  
**Démontage et montage moteur complet**  
**Smontaggio e rimontaggio completo del motore**

**Werkstatthandbuch BFM 1012/E, BFM 1013/E**

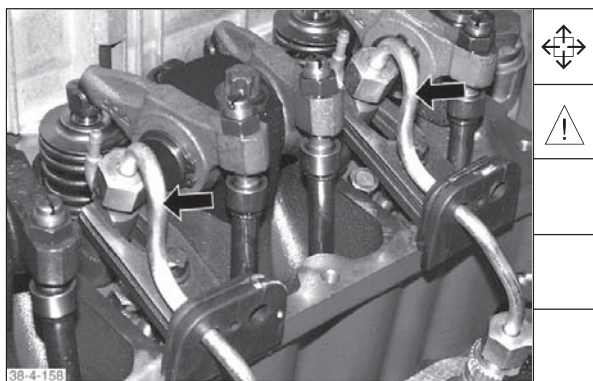
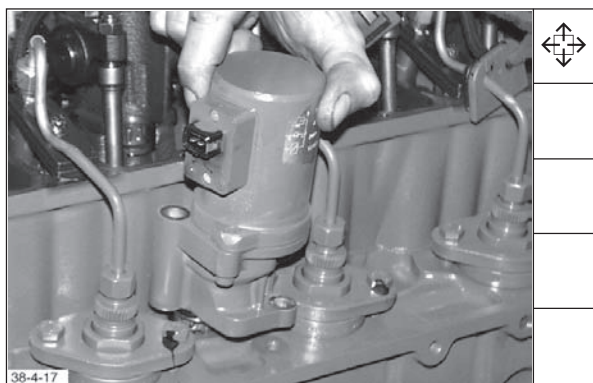
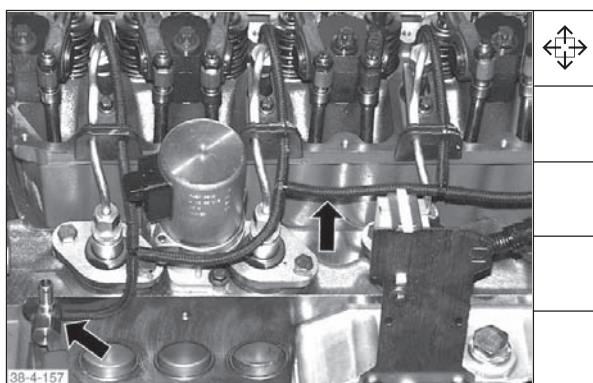

**Deutsch**

24. Zylinderkopfhaube abbauen.  
 Falls vorhanden, Verkabelung mitabbauen.

25. Leckölleitung mit Überströmventil  
 abbauen.

26. Abstellmagnet ausbauen.

27. Einspritzleitungen mit Dichtgummis ab-  
 bauen.

**Hinweis:** Öffnungen verschließen.

**Demontage und Montage, Motor komplett**  
**Disassembly and reassembly of complete engine**  
**Démontage et montage moteur complet**  
**Smontaggio e rimontaggio completo del motore**

English	Français	Italiano
24. Remove cylinder head cover. Remove cabling as well if any.	24. Déposer la culasse. Si le moteur est équipé d'un câblage, le déposer.	24. Smontare il coperchio delle punterie. Nel caso in cui ci siano, smontare pure i cavi.
25. Remove backleakage pipe together with overflow valve.	25. Déposer le tuyau de retour des fuites avec la soupape de décharge.	25. Smontare la tubazione di ricupero del gasolio assieme alla valvola limitatrice della pressione.
26. Remove shutdown solenoid.	26. Déposer l'électroaimant d'arrêt.	26. Smontare l'elettromagnete di arresto.
26. Remove injection lines complete with sealing rubber. <b>Note:</b> Cover up openings.	27. Déposer les tuyauteries d'injection avec les caoutchoucs d'étanchéité. <b>Nota:</b> obturer les orifices.	27. Smontare le tubazioni di iniezione con tenute di gomma. <b>Nota:</b> Chiudere le aperture.

**Demontage und Montage, Motor komplett**  
**Disassembly and reassembly of complete engine**  
**Démontage et montage moteur complet**  
**Smontaggio e rimontaggio completo del motore**

English	Français	Italiano
28. Remove injectors.  <b>Note:</b> If sticking, use disassembly tool No. 150 800 with extractor No. 110 030.	28. Déposer les injecteurs.  <b>Nota:</b> en cas de blocage utiliser dispositif No. 150 800 avec extracteur No. 110 030.	28. Smontare gli iniettori.  <b>Nota:</b> Se sono incollati utilizzare il dispositivo di estrazione nr. 150 800 assieme all'estrattore nr. 110 030.
29. Remove glow plugs if any.	29. Si le moteur est équipé de bougies de préchauffage, les déposer.	29. Nel caso in cui ci siano, smontare le candele ad incandescenza.
30. Remove rocker arm brackets.	30. Déposer les supports de culbuteurs.	30. Smontare i supporti dei bilancieri.
31. Take out pushrods.	31. Retirer les tiges de culbuteurs.	31. Estrarre le aste delle punterie.

**Demontage und Montage, Motor komplett**  
**Disassembly and reassembly of complete engine**  
**Démontage et montage moteur complet**  
**Smontaggio e rimontaggio completo del motore**

**Deutsch**

**Werkstatthandbuch BFM 1012/E, BFM 1013/E**

28. Einspritzventile ausbauen.

**Hinweis:** Bei Festsitz Ausziehvorrichtung  
Nr.150 800 mit Auszieher Nr.110 030  
verwenden.

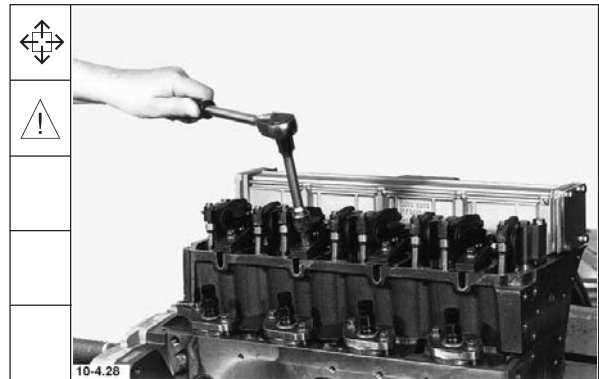

29. Falls vorhanden, Glühkerzen ausbauen.

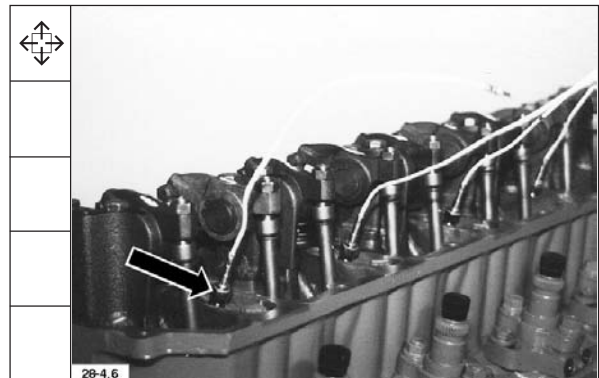

30. Kippschraube abbauen.

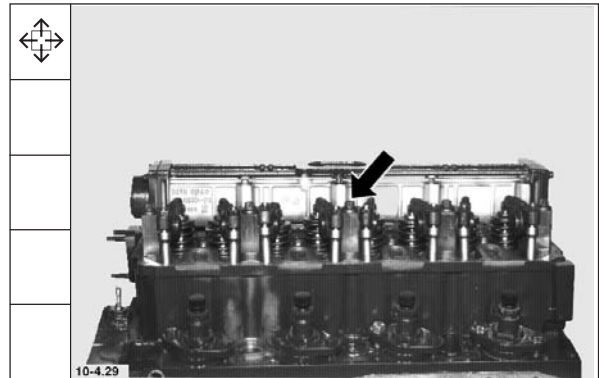

31. Stoßstangen herausnehmen.

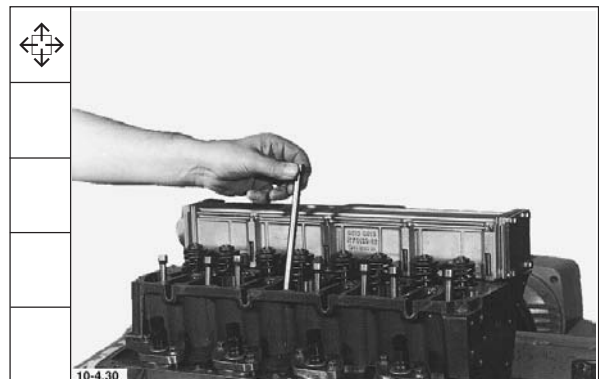

**Demontage und Montage, Motor komplett**  
**Disassembly and reassembly of complete engine**  
**Démontage et montage moteur complet**  
**Smontaggio e rimontaggio completo del motore**

Werkstatthandbuch BFM 1012/E, BFM 1013/E

Deutsch

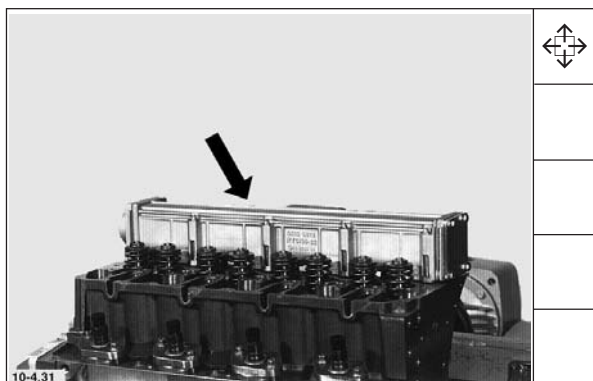

32. Ladeluftleitung abbauen.

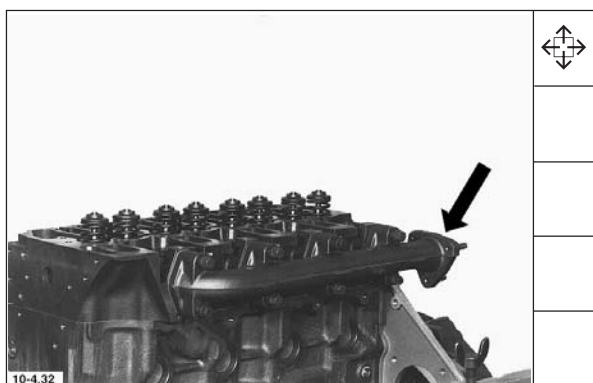

33. Abgassammelrohr abbauen.

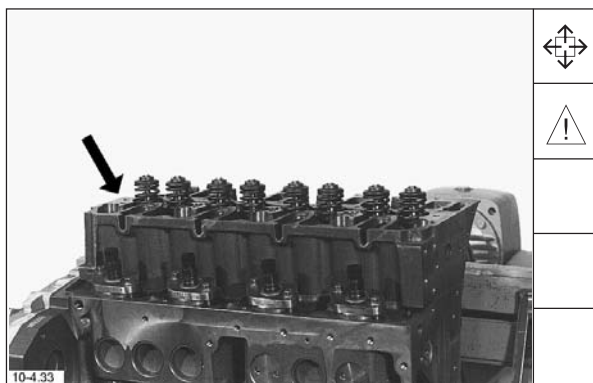

34. Zylinderkopf abbauen. Dichtung entfernen.

**Hinweis:** Torx E14 / E18 verwenden.

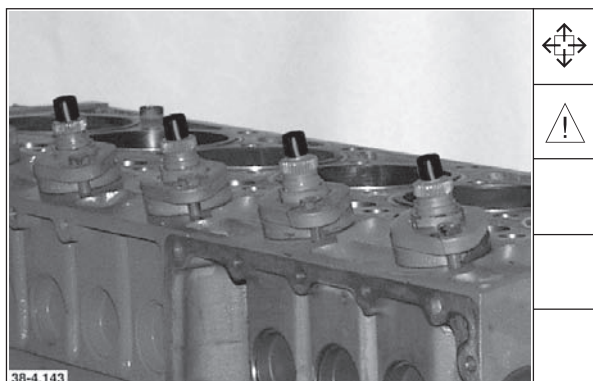

35. Einspritzpumpen ausbauen.

**Hinweis:** Auf Ausgleichsscheiben achten.

**Demontage und Montage, Motor komplett**  
**Disassembly and reassembly of complete engine**  
**Démontage et montage moteur complet**  
**Smontaggio e rimontaggio completo del motore**

English	Français	Italiano
32. Remove charge air pipe.	32. Déposer la conduite d'air de suralimentation.	32. Smontare la tubazione dell'aria di sovralimentazione.
33. Remove exhaust manifold.	33. Déposer le collecteur d'échappement.	33. Smontare il collettore di scarico.
34. Remove cylinder head. Take off gasket.	34. Déposer la culasse. Oter le joint.	34. Smontare la testa cilindri. Smontare pure la guarnizione.
<b>Note:</b> Use E14/E18 Torx tool.	<b>Nota:</b> utiliser l'outil Torx E14/E18.	<b>Nota:</b> Utilizzare gli attrezzi Torx E 14 / E 18.
35. Remove injection pumps.	35. Déposer les pompes d'injection.	35. Smontare le pompe d'iniezione.
<b>Note:</b> Watch out for shims.	<b>Nota:</b> veiller aux rondelles de compensation.	<b>Nota:</b> Fare attenzione agli spessori.



**Demontage und Montage, Motor komplett**  
**Disassembly and reassembly of complete engine**  
**Démontage et montage moteur complet**  
**Smontaggio e rimontaggio completo del motore**

English	Français	Italiano
36. Take out roller tappets together with shims.	36. Retirer le poussoir à galets avec les rondelles de compensation.	36. Estrarre le punterie a rullo e relativi spessori
37. Pull out oil dipstick.	37. Retirer la jauge d'huile.	37. Estrarre l'astina di livello dell'olio.
38. Remove cover plate. Turn engine by 180°.	38. Déposer la tôle de recouvrement. Virer le moteur de 180°.	38. Smontare il lamierino di copertura. Ruotare il motore di 180°.
<b>Note:</b> Catch any escaping oil and dispose of in accordance with anti-pollution regulations.	<b>Nota:</b> récupérer l'huile qui s'écoule en respectant la réglementation antipollution.	<b>Nota:</b> Raccogliere l'olio che cola fuori e smaltirlo secondo le vigenti prescrizioni.
39. Turn engine by 90°. Remove adapter housing.	39. Virer le moteur de 90°. Déposer le carter d'adaptation.	39. Ruotare il motore di 90°. Smontare la campana di accoppiamento.
<b>Note:</b> Use Torx tools E20 and E14.	<b>Nota:</b> utiliser Torx E20 et E14.	<b>Nota:</b> Utilizzare le chiavi a tubo Torx E20 ed E14.



Deutsch

Werkstatthandbuch BFM 1012/E, BFM 1013/E

36. Rollenstößel mit Ausgleichscheiben herausnehmen.



37. Ölmeßstab herausziehen.

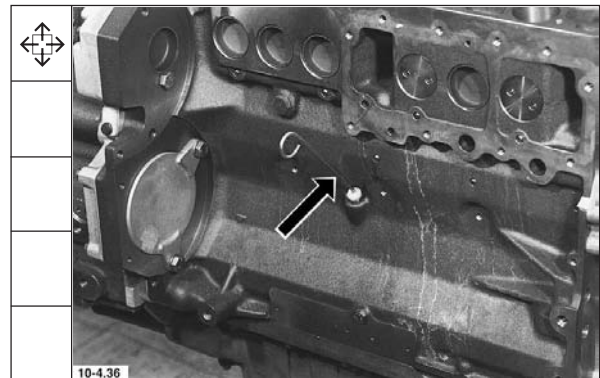

38. Abdeckblech abbauen.  
Motor um 180° drehen.

**Hinweis:** Auslaufendes Öl auffangen und vorschriftsmäßig entsorgen.

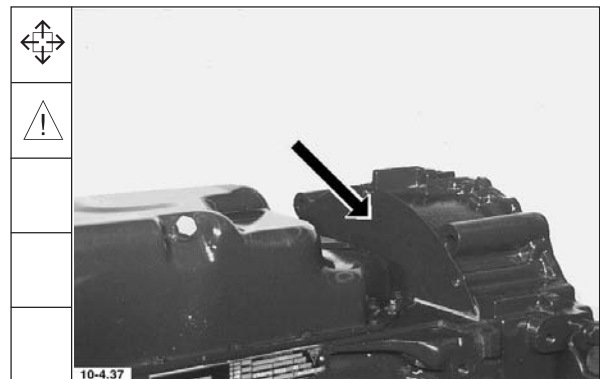

39. Motor um 90° drehen. Anschlußgehäuse abbauen.

**Hinweis:** Torx E20 und E14 verwenden.



# Demontage und Montage, Motor komplett Disassembly and reassembly of complete engine Démontage et montage moteur complet Smontaggio e rimontaggio completo del motore

Werkstatthandbuch BFM 1012/E, BFM 1013/E

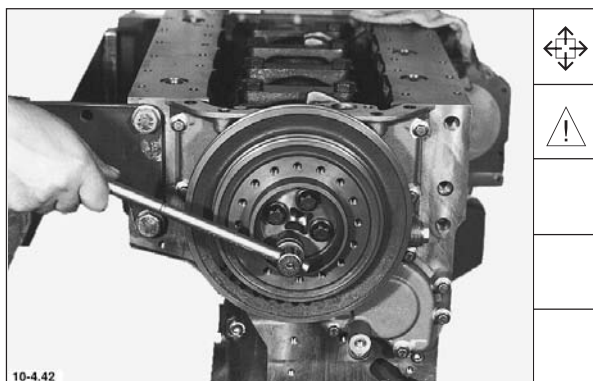
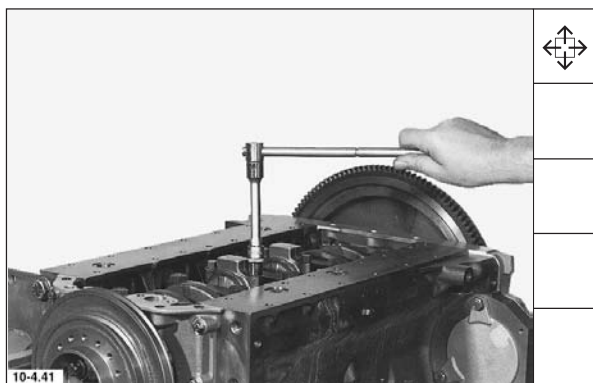
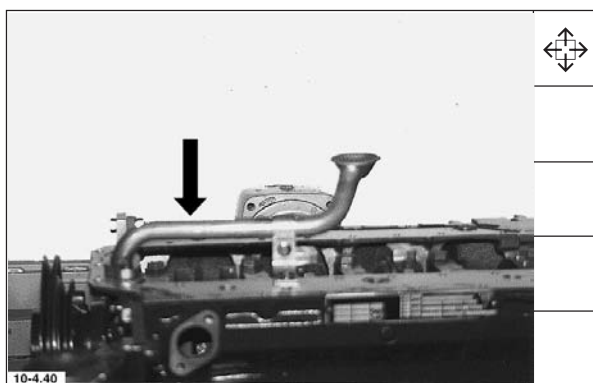
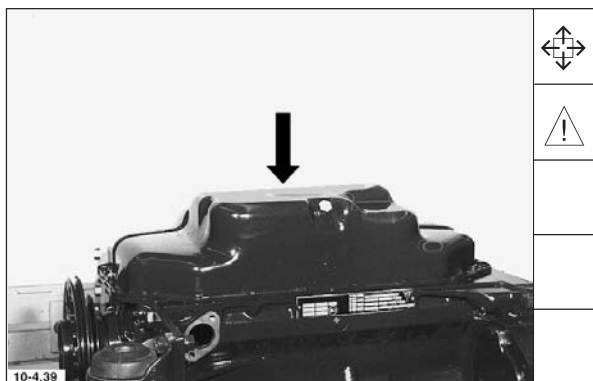

## Deutsch

40. Motor um 90° drehen. Ölwanne abbauen.

**Hinweis:** Einbaulage des Ölsumpfs markieren.

41. Ölansaugrohr abbauen.

42. Kolben mit Pleuel ausbauen.

43. Keilriemenscheibe abbauen.

**Hinweis:** Torx E20 verwenden.

**Demontage und Montage, Motor komplett**  
**Disassembly and reassembly of complete engine**  
**Démontage et montage moteur complet**  
**Smontaggio e rimontaggio completo del motore**

English	Français	Italiano
40. Turn engine by 90°. Remove oil pan.  <b>Note:</b> Mark installation position of oil sump.	40. Virer le moteur de 90°. Déposer le carter d'huile.  <b>Nota:</b> repérer le sens de montage du carter d'huile.	40. Ruotare il motore di 90°. Smontare la coppa del motore  <b>Nota:</b> Marcare la posizione in cui è montata la coppa dell'olio.
41. Remove oil suction pipe.	41. Déposer le tube d'aspiration d'huile.	41. Smontare il tubo di aspirazione dell'olio.
42. Remove piston complete with connecting rod.	42. Déposer l'ensemble piston-bielle.	42. Smontare i pistoni assieme alle bielle.
43. Remove V-belt pulley.  <b>Note:</b> Use Torx tool E20.	43. Déposer la poulie à gorge.  <b>Nota:</b> utiliser Torx E20.	43. Smontare la puleggia della cinghia trapezoidale  <b>Nota:</b> Utilizzare la chiave a tubo Torx E20.

**Demontage und Montage, Motor komplett**  
**Disassembly and reassembly of complete engine**  
**Démontage et montage moteur complet**  
**Smontaggio e rimontaggio completo del motore**

English	Français	Italiano
44. Remove front cover.	44. Déposer le couvercle avant.	44. Smontare il coperchio anteriore.
45. Remove flywheel.	45. Déposer le volant moteur.	45. Smontare il volano.
46. Remove timing chest cover.	46. Déposer le couvercle du carter de distribution.	46. Smontare il coperchio della scatola della distribuzione.
47. Remove main bearing caps.	47. Déposer le chapeau de palier de vilebrequin.	47. Smontare i cappelli dei cuscinetti di banco.

**Deutsch**

**Werkstatthandbuch BFM 1012/E, BFM 1013/E**

44. Vorderen Deckel abbauen.

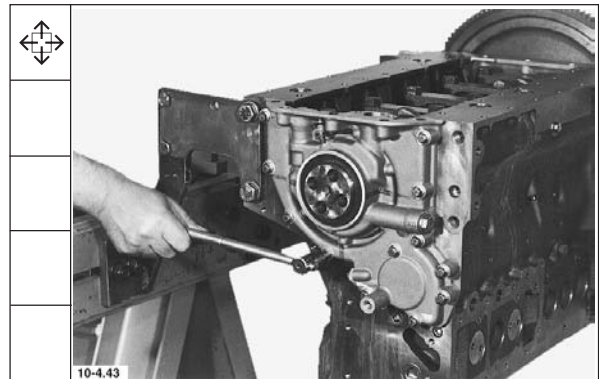

45. Schwungrad abbauen.

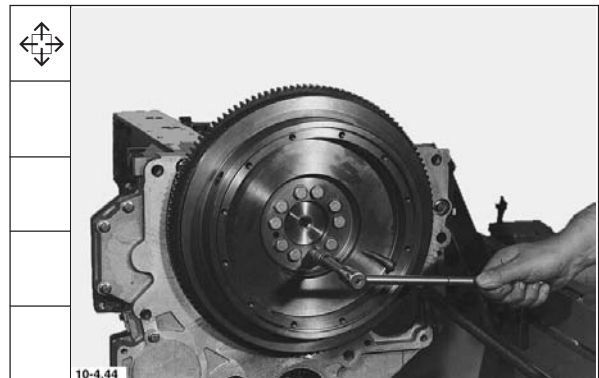

46. Räderkastendeckel abbauen.

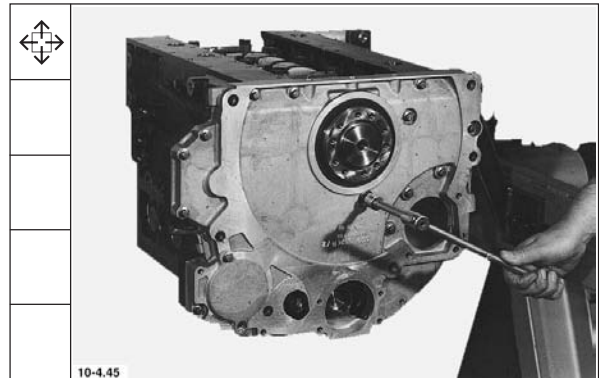

47. Hauptlagerdeckel ausbauen.

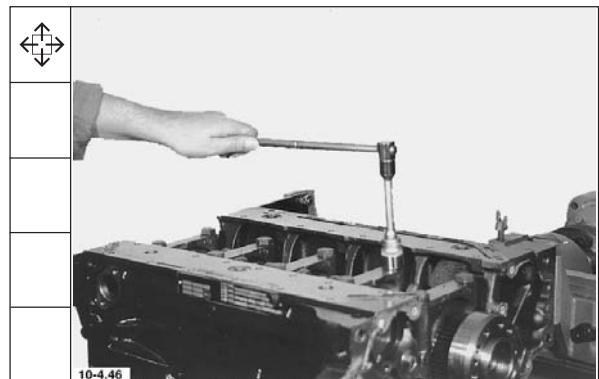

**Demontage und Montage, Motor komplett**  
**Disassembly and reassembly of complete engine**  
**Démontage et montage moteur complet**  
**Smontaggio e rimontaggio completo del motore**

Werkstatthandbuch BFM 1012/E, BFM 1013/E

Deutsch

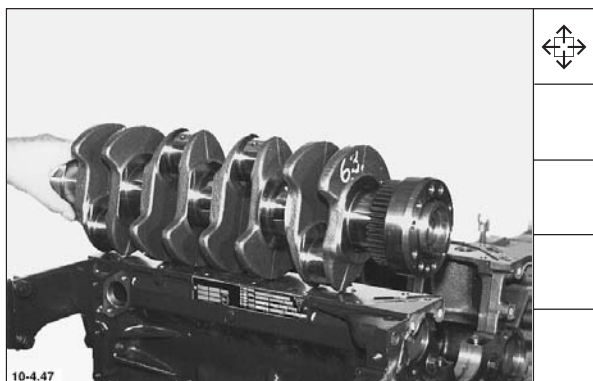

48. Kurbelwelle herausnehmen.



49. Anlaufringe und Lagerschalenhälften herausnehmen.

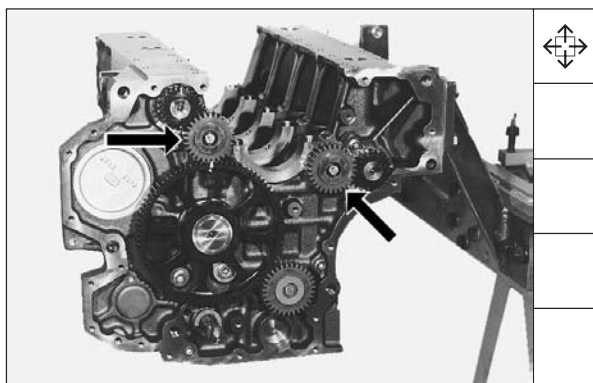

50. Falls vorhanden, Antriebsräder für Ausgleichswellen ausbauen.

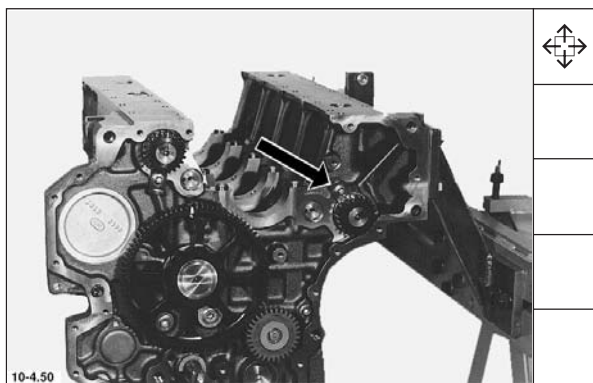

51. Falls vorhanden, Anlaufscheiben für Ausgleichswellen abbauen.

**Demontage und Montage, Motor komplett**  
**Disassembly and reassembly of complete engine**  
**Démontage et montage moteur complet**  
**Smontaggio e rimontaggio completo del motore**

English	Français	Italiano
48. Lift out crankshaft.	48. Extraire le vilebrequin.	48. Estrarre l'albero a gomiti.
49. Take out thrust rings and bearing shell halves.	49. Retirer les flasques de butée et les demi-coussinets.	49. Sfilare gli anelli di rasamento ed i semigusci dei cuscinetti.
50. Remove drive gears for balancing shafts if any.	50. Retirer les pignons d'entraînement des arbres à masse d'équilibrage si le moteur en est équipé.	50. Nel caso in cui esistano, smontare gli ingranaggi di comando degli alberi di equilibratura delle masse.
51. Remove thrust washers for balancing shafts if any.	51. Selon l'équipement du moteur déposer les flasques de butée des arbres à masse d'équilibrage.	51. Nel caso in cui ci siano, smontare le rondelle di rasamento degli alberi di equilibratura delle masse.

**Demontage und Montage, Motor komplett**  
**Disassembly and reassembly of complete engine**  
**Démontage et montage moteur complet**  
**Smontaggio e rimontaggio completo del motore**

English	Français	Italiano
52. Take out balancing shafts if any.	52. Selon l'équipement du moteur retirer les arbres à masses d'équilibrage.	52. Se esistono, estrarre gli alberi di equilibratura delle masse.
53. Remove drive gear for governor.	53. Dépose le pignon d'entraînement du régulateur de vitesse.	53. Smontare l'ingranaggio di comando del regolatore dei giri del motore.
54. Take out camshaft.	54. Retirer l'arbre à cames.	54. Smontare l'albero a camme
55. Remove guide sleeve. Take out control rod.	55. Déposer la douille de guidage et retirer la crémaillère.	55. Smontare le boccole di guida. Estrarre l'asta a cremagliera.



**Deutsch**

**Werkstatthandbuch BFM 1012/E, BFM 1013/E**

52. Falls vorhanden, Ausgleichswellen herausnehmen.



53. Antriebsrad für Drehzahlregler ausbauen.

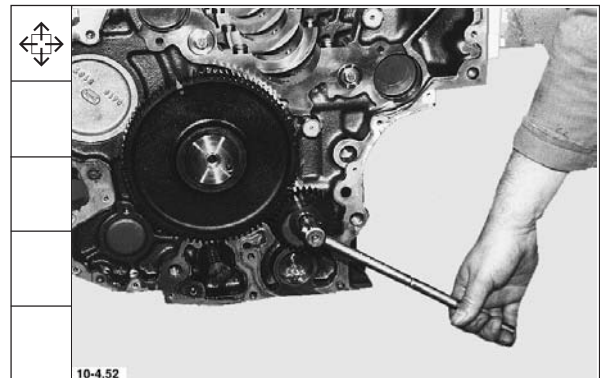

54. Nockenwelle herausnehmen.

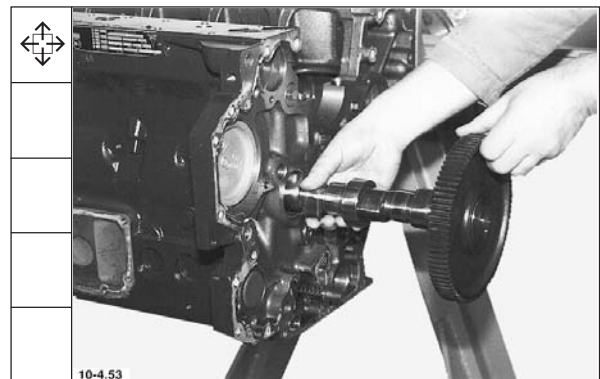

55. Führungsbuchse abbauen. Regelstange herausnehmen.

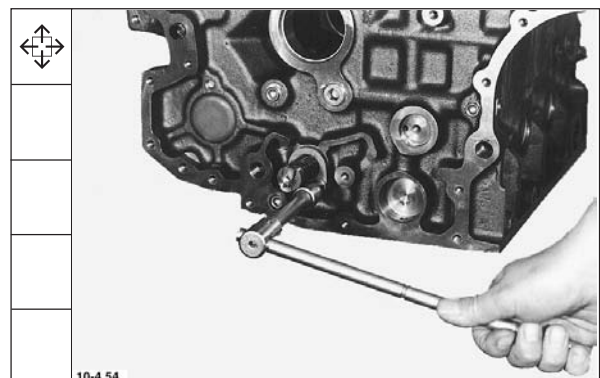

**Demontage und Montage, Motor komplett**  
**Disassembly and reassembly of complete engine**  
**Démontage et montage moteur complet**  
**Smontaggio e rimontaggio completo del motore**

Werkstatthandbuch BFM 1012/E, BFM 1013/E

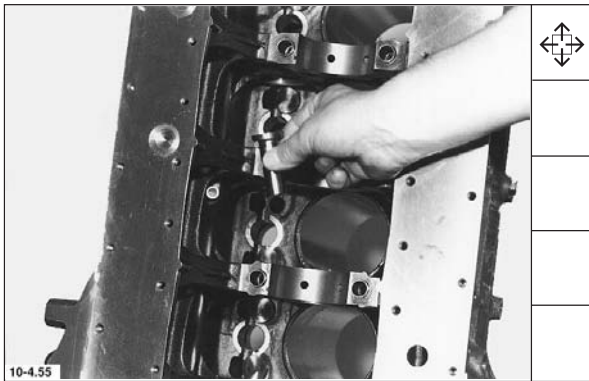

Deutsch

56. Stößel herausnehmen.

57. Ölspritzdüsen herausdrücken.  
Ölkanäle auf freien Durchlaß prüfen.

**Demontage und Montage, Motor komplett**  
**Disassembly and reassembly of complete engine**  
**Démontage et montage moteur complet**  
**Smontaggio e rimontaggio completo del motore**

English	Français	Italiano
56. Take out tappets.	56. Retirer les poussoirs.	56. Estrarre le punterie.
57. Press out oil spray nozzles. Check oil ducts for free passage.	57. Extraire les gicleurs d'huile. Vérifier le libre passage des canalisations d'huile.	57. Estrarre gli spruzzatori d'olio. Controllare che i canali di passaggio dell'olio siano liberi.

**Demontage und Montage, Motor komplett**  
**Disassembly and reassembly of complete engine**  
**Démontage et montage moteur complet**  
**Smontaggio e rimontaggio completo del motore**

English	Français	Italiano
<b>Reassembling engine</b>	<b>Démontage et montage moteur complet</b>	<b>Riassemblaggio del motore</b>
<b>Commercial tools required:</b>	<b>Outillage usuel :</b>	<b>Attrezzi normali:</b>
Torx tool set _____ 8189	Jeu d'outils Torx _____ 8189	Kit di attrezzi Torx _____ 8189
Torx socket wrench E14 _____ 8113	Clé à douille Torx E14 _____ 8113	Chiave a tubo E14 Torx _____ 8113
Torx socket wrench E18 _____ 8116	Clé à douille Torx E18 _____ 8116	Chiave a tubo E18 Torx _____ 8116
Torx socket wrench E20 _____ 8114	Clé à douille Torx E20 _____ 8114	Chiave a tubo E20 Torx _____ 8114
Hose clamp pliers _____ 9090	Pince pour tuyaux souples _____ 9090	Pinza per tubi flessibili _____ 9090
Hose clamp pliers _____ 9088	Pince pour tuyaux souples _____ 9088	Pinza per tubi flessibili _____ 9088
V-belt tension gauge _____ 8115	Appareil de mesure de tension de trapézoïdale _____ 8115	Attrezzo di controllo tensione della cinghia trapezoidale _____ 8115
Serrated wrench for turning I.P. _____ 8117	Clé à douille (polygomale) pour pompe d'injection _____ 8117	Chiave (multident) per pompe d'iniezione _____ 8117
Cobra clamp pliers _____ 8011	Pince de serrage Cobra _____ 8011	Pinza per morsetti Cobra _____ 8011
<b>Special tools required:</b>	<b>Outillage spécial :</b>	<b>Attrezzi speciali:</b>
Dial gauge M2T _____ 100 400	Comparateur M2T _____ 100 400	Comparatore M2T _____ 100 400
Measuring device _____ 100 750	Appareil de mesure _____ 100 750	Apparecchio di misura _____ 100 750
Measuring device BFM 1012 _____ 100 780	Dispositif de montage BFM 1012 _____ 100 780	Dispositivo di misura per BFM 1012 _____ 100 780
_____ 100 860	_____ 100 860	_____ 100 860
BFM 1013 _____ 100 840	BFM 1013 _____ 100 840	per BFM 1013 _____ 100 840
Measuring device/locking device for control rod _____ 100 800	Appareil de mesure / appareil à bloquer pour crémaillère _____ 100 800	Appar. di misura/bloccaggio per l'asta a cremagliera _____ 100 800
Adjusting pin for mass balancing shafts BFM 1012 _ 100 810	Pige de réglage pour arbres équilibres BFM 1012 _____ 100 810	Perno regol. per gli alberi di equilibratura delle masse _____ 100 810
Graduated disc _____ 101 020	Echelle graduée _____ 101 020	Disco graduato _____ 101 020
Adapter for graduated disc _ 101 030	Adaptateur pour échelle graduée _____ 101 030	Adattatore per disco grad. _____ 101 030
Pointer _____ 101 300	Index graduée _____ 101 300	Indicatore _____ 101 300
Piston ring compressor BFM 1012 _____ 130 630	Sangle à comprimer les segments de piston BFM 1012 _____ 130 630	Espansore per fasce elastiche BFM 1012 _____ 130 630
BFM 1013 _____ 130 640	BFM 1013 _____ 130 640	BFM 1013 _____ 130 640
<b>Oil spray nozzles</b>	<b>Gicleurs de refroidissement</b>	<b>Spruzzatori dell'olio</b>
1. Press in oil spray nozzles as far as they will go.	1. Insérer les gicleurs jusqu'en position de butée.	1. Inserire gli spruzzatori dell'olio di raffreddamento, premendoli fino a battuta.

## Deutsch

## Werkstatthandbuch BFM 1012/E, BFM 1013/E

### Motor zusammenbauen

#### Handelsübliche Werkzeuge:

Torx-Werkzeugsatz _____	8189
Torx-Steckschlüssel E14 _____	8113
Torx-Steckschlüssel E18 _____	8116
Torx-Steckschlüssel E20 _____	8114
Schlauchklemmenzange _____	9090
Schlauchklemmenzange _____	9088
Keilriemenspannungsmeßgerät _____	8115
Verdrehschlüssel (Vielzahn) für E.-Pumpe _____	8117
Cobraklemmenzange _____	8011

#### Spezialwerkzeuge:

Meßuhr M2T _____	100 400
Meßgerät _____	100 750
Meßvorrichtung BFM 1012 _____	100 780
	100 860
BFM 1013 _____	100 840
Meßgerät / Blockiergerät für Regelstange _____	100 800
Einstellbolzen für MAG Wellen BFM 1012 _____	100 810
Gradscheibe _____	101 020
Adapter für Gradscheibe _____	101 030
Zeiger _____	101 300
Kolbenringspannband BFM 1012 _____	130 630
BFM 1013 _____	130 640

### Ölspritzdüsen

1. Ölspritzdüsen bis Anlage eindrücken.

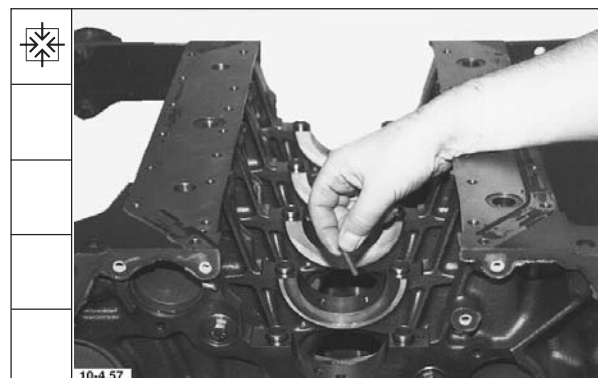

**Demontage und Montage, Motor komplett**  
**Disassembly and reassembly of complete engine**  
**Démontage et montage moteur complet**  
**Smontaggio e rimontaggio completo del motore**

**Werkstatthandbuch BFM 1012/E, BFM 1013/E**

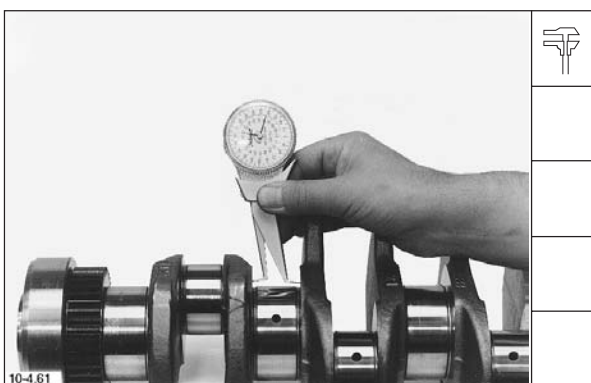
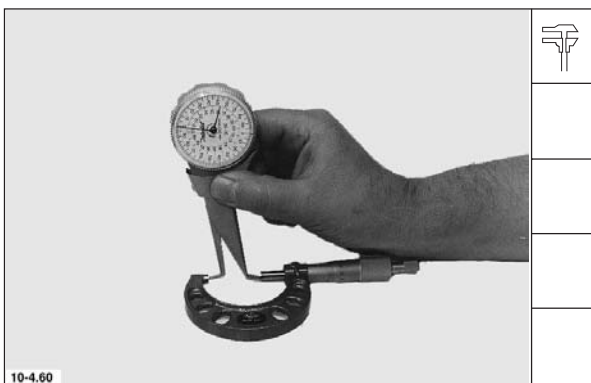
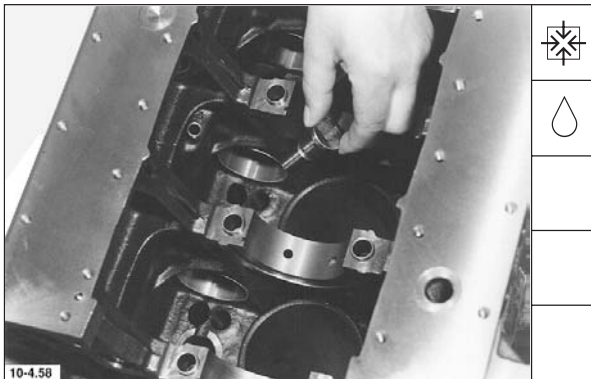

**Deutsch**

**Stößel/Nockenwelle**

2. Stößel einsetzen.
  
  
  
  
  
  
3. Nockenwelle einsetzen.

**Kurbelwellenlagerung**

4. Innenmeßgerät einstellen.

BFM 1012 auf **36 mm**  
 BFM 1013 auf **38 mm**

5. Paßlagerbreite der Kurbelwelle messen und notieren. Maß "a"
- Zapfenbreite normal:
- |          |       |                     |
|----------|-------|---------------------|
| BFM 1012 | _____ | <b>36 + 0,04 mm</b> |
| BFM 1013 | _____ | <b>38 + 0,06 mm</b> |
- Grenzmaß für Übermaßstufe:
- |          |       |                      |
|----------|-------|----------------------|
| BFM 1012 | _____ | <b>36,4 + 0,04mm</b> |
| BFM 1013 | _____ | <b>38,4 + 0,06mm</b> |

**Demontage und Montage, Motor komplett**  
**Disassembly and reassembly of complete engine**  
**Démontage et montage moteur complet**  
**Smontaggio e rimontaggio completo del motore**

English	Français	Italiano
<p><b>Tappets/camshaft</b></p> <p>2. Insert tappets.</p> <p>3. Introduce camshaft.</p>	<p><b>Poussoir/arbre à cames</b></p> <p>2. Mettre en place le poussoir.</p> <p>3. Mettre en place l'arbre à cames.</p>	<p><b>Punterie / Albero a camme</b></p> <p>2. Inserire le punterie.</p> <p>3. Introdurre l'albero a camme.</p>
<p><b>Crankshaft bearings</b></p> <p>4. Set internal gauge:</p> <p style="padding-left: 40px;">BFM 1012 to <b>36 mm</b> BFM 1013 to <b>38 mm</b></p> <p>5. Gauge width of crankshaft thrust bearing journal and record. Dimension „a“</p> <p style="padding-left: 40px;">Standard journal width: BFM 1012 _____ <b>36 + 0.04 mm</b> BFM 1013 _____ <b>38 + 0.06 mm</b></p> <p style="padding-left: 40px;">Limit for oversize: BFM 1012 _____ <b>36.4 + 0.04 mm</b> BFM 1013 _____ <b>38.4 + 0.06 mm</b></p>	<p><b>Paliers de vilebrequin</b></p> <p>4. Régler l'appareil de mesure selon le moteur:</p> <p style="padding-left: 40px;">BFM 1012 à <b>36 mm</b>. BFM 1013 à <b>38 mm</b>.</p> <p>5. Mesurer la largeur des portées du palier de butée du vilebrequin et la noter. Cote „a“.</p> <p style="padding-left: 40px;">Largeur normale du tourillon : BFM 1012 _____ <b>36 + 0,04 mm</b> BFM 1013 _____ <b>38 + 0,06 mm</b></p> <p style="padding-left: 40px;">Cote limite de réparation: BFM 1012 _____ <b>36,4 + 0,04 mm</b> BFM 1013 _____ <b>38,4 + 0,06 mm</b></p>	<p><b>Cuscinetti di banco</b></p> <p>4. Regolare il micrometro per interni.</p> <p style="padding-left: 40px;">BFM 1012 su <b>36 mm</b> BFM 1013 su <b>38 mm</b></p> <p>5. Misurare la larghezza del cuscinetto di centraggio dell'albero a gomiti e prenderne nota. Misura "a"</p> <p style="padding-left: 40px;">Normale larghezza dei perni: BFM 1012 _____ <b>36 + 0,04 mm</b> BFM 1013 _____ <b>38 + 0,06 mm</b></p> <p style="padding-left: 40px;">Misura limite per grado di minoraz: BFM 1012 _____ <b>36,4 + 0,04 mm</b> BFM 1013 _____ <b>38,4 + 0,06 mm</b></p>

**Demontage und Montage, Motor komplett**  
**Disassembly and reassembly of complete engine**  
**Démontage et montage moteur complet**  
**Smontaggio e rimontaggio completo del motore**

**English**

6. Insert bearing shells.

7. Insert bearing shells in main bearing caps.

8. Place half thrust rings on thrust bearing cap, gauge and record width. Dimension „b“

9. Determine end float.

Example BFM 1012:

Dimension a = **36,04 mm**

Dimension b = **35,90 mm**

Dimension a - dimension b  
 = **end float = 0,14 mm**

Permissible end float for:

BFM 1012 = **0,10 - 0,30 mm**

BFM 1013 = **0,10 - 0,30 mm**

**Français**

6. Mettre en place les coussinets.

7. Placer les coussinets dans le chapeau de palier de vilebrequin.

8. Adapter les demi-flasques de butée au chapeau du palier de butée, en mesurer la largeur et la noter. Cote „b“.

9. Calculer le jeu axial.

Exemple BFM 1012:

cote a = **36,04 mm**

cote b = **35,90 mm**

cote a - cote b = **jeu axial**  
 = **0,14 mm**

Jeu axial admis pour

BFM 1012 = **0,10 - 0,30 mm**

BFM 1013 = **0,10 - 0,30 mm**

**Italiano**

6. Montare i semigusci dei cuscinetti di banco.

7. Montare i semigusci nei cappelli dei cuscinetti di banco.

8. Posizionare i semianelli di spallamento nel cappello del cuscinetto di centraggio. Misurarne la larghezza e prendere nota della misura "b".

9. Calcolare il gioco assiale.

Esempio per il BFM 1012:

misura a = **36,04 mm**

misura b = **35,90 mm**

misura a - misura b = **gioco assiale**  
 = **0,14 mm**

Gioco assiale ammesso per:

BFM 1012 = **0,10 - 0,30 mm**

BFM 1013 = **0,10 - 0,30 mm**



Deutsch

Werkstatthandbuch BFM 1012/E, BFM 1013/E

6. Lagerschalen einsetzen.

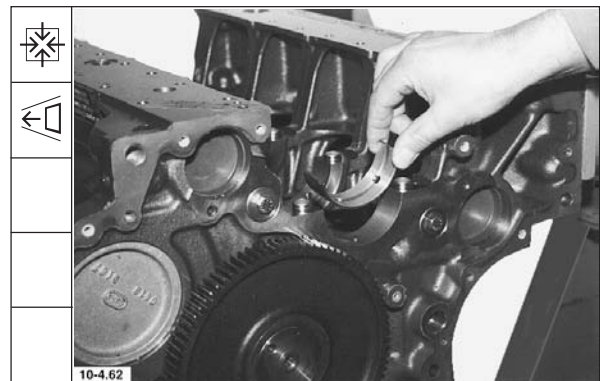

7. Lagerschalen in Hauptlagerdeckel einsetzen.



8. Anlaufringhälften an Paßlagerdeckel anlegen, Breite messen und notieren.  
Maß "b"



9. Axialspiel ermitteln.

Beispiel BFM 1012:

Maß a = **36,04 mm**

Maß b = **35,90 mm**

Maß a - Maß b = **Axialspiel**  
= **0,14 mm**

Zulässiges Axialspiel für:

BFM 1012 = **0,10 - 0,30 mm**

BFM 1013 = **0,10 - 0,30 mm**

**Demontage und Montage, Motor komplett**  
**Disassembly and reassembly of complete engine**  
**Démontage et montage moteur complet**  
**Smontaggio e rimontaggio completo del motore**

Werkstatthandbuch BFM 1012/E, BFM 1013/E

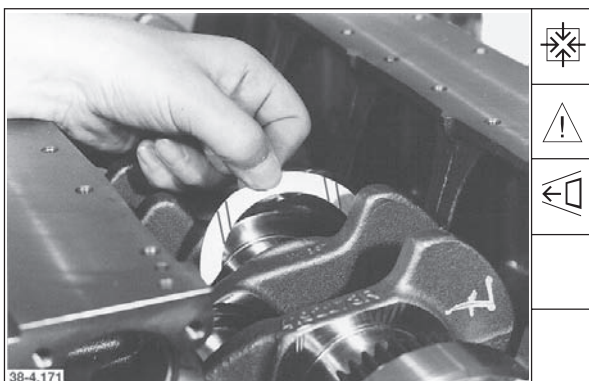
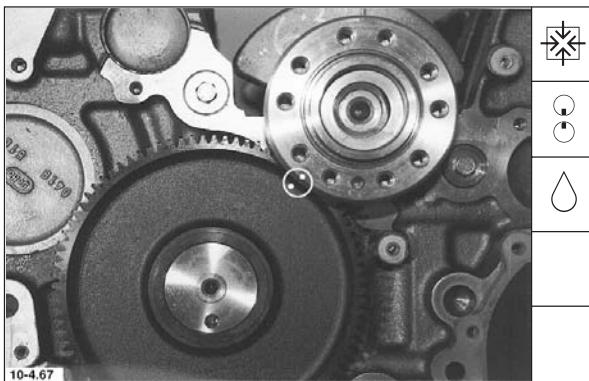
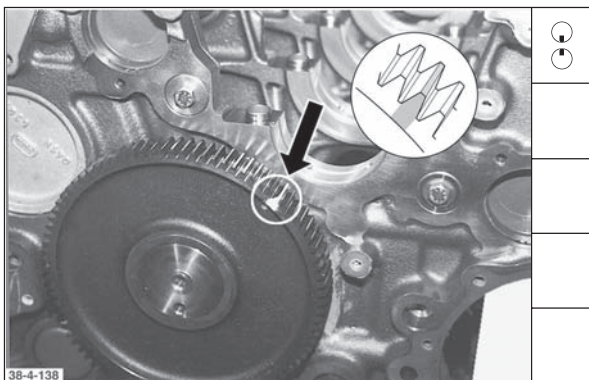

**Deutsch**

10. Kurbelwelle vor Einbau markieren.

11. Nockenwelle markieren und positionieren.

12. Kurbelwelle einsetzen.  
 Beim Einbau müssen die Markierungen in Überdeckung stehen.

13. Anlaufringhälften ohne Führungsnase einsetzen.

**Hinweis:** Anlaufringe müssen mit der Laufschichtseite zum Wangenspiegel der Kurbelwelle weisen.

**Demontage und Montage, Motor komplett**  
**Disassembly and reassembly of complete engine**  
**Démontage et montage moteur complet**  
**Smontaggio e rimontaggio completo del motore**

English	Français	Italiano
10. Mark crankshaft prior to installation.	10. Avant de le monter repérer le vilebrequin.	10. Prima di montarlo, contrassegnare l'albero a gomiti.
11. Mark camshaft and place in position.	11. Repérer l'arbre à cames et le positionner.	11. Contrassegnare l'albero a camme e posizionarlo.
12. Introduce crankshaft. Marks must be in line.	12. Mettre en place le vilebrequin. Au montage il faut que les repères coïncident.	12. Montare l'albero motore. All'atto del montaggio i contras- segni devono coincidere.
13. Insert half thrust rings without lug.  <b>Note:</b> Running layer of thrust rings must face towards crankweb.	13. Mettre en place les demi-flasques de butée sans taquet de guidage.  <b>Nota:</b> les flasques de butée avec leur face de roulement doivent être orientées vers la joue du vilebrequin.	13. Inserire i semianelli di spallamento senza sporgenza di guida.  <b>Nota:</b> Gli anelli di spallamento devono avere il lato con lo strato di scorrimento rivolto verso la spalla dell'albero a gomiti.

# Demontage und Montage, Motor komplett

## Disassembly and reassembly of complete engine

### Démontage et montage moteur complet

### Smontaggio e rimontaggio completo del motore

English	Français	Italiano
<p>14. Stick half thrust rings with lug to thrust bearing cap using some grease.</p> <p><b>Note:</b> Running layer of thrust rings must face towards crankweb.</p>	<p>14. Avec un peu de graisse coller sur le chapeau de palier de butée les demi-flasques de butée avec le taquet de guidage.</p> <p><b>Nota:</b> le chapeau de palier no. 1 est du côté du volant moteur. Les bossages doivent être orientés vers le volant moteur.</p>	<p>14. Incollare con un po' di grasso sul cappello del cuscinetto di centraggio i semianelli di spallamento senza sporgenza di guida.</p> <p><b>Nota:</b> Gli anelli di spallamento devono avere il lato con lo strato di scorrimento rivolto verso la spalla dell'albero a gomiti.</p>
<p>15. Mount thrust bearing cap.</p> <p><b>Note:</b> Bearing cap No. 1 at flywheel end. Bosses must face towards flywheel on BFM 1012.</p>	<p>15. Mettre en place le chapeau de palier de butée.</p> <p><b>Nota:</b> le chapeau de palier no. 1 est orienté côté volant moteur. Sur le BFM 1012 les bossages doivent être orientés vers le volant moteur.</p>	<p>15. Montare il cappello del cuscinetto di centraggio.</p> <p><b>Nota:</b> Il cappello del cuscinetto nr. 1 è quello che si trova sul lato volano. Nel caso del BFM 1012 gli oggetti devono essere rivolti verso il volano.</p>
<p>16. Mount main bearing caps, paying attention to the numbering.</p>	<p>16. Monter le chapeau de palier de vilebrequin selon la numérotation.</p>	<p>16. Montare i cappelli dei cuscinetti di banco in base alla loro numerazione.</p>
<p>17. Tighten main bearing bolts according to specification.</p> <p>Initial tightening torque</p> <p>BFM 1012: _____ <b>30 Nm</b></p> <p>BFM 1013: _____ <b>50 Nm</b></p> <p>1st tightening angle _____ <b>60°</b></p> <p>2nd tightening angle _____ <b>60°</b></p> <p><b>Note:</b> Bolts may be used <b>3x</b> if evidence can be provided concerning their use.</p>	<p>17. Serrer les vis de palier principal selon les préconisations de serrage.</p> <p>Valeur de préserrage</p> <p>BFM 1012: _____ <b>30 Nm</b></p> <p>BFM 1013: _____ <b>50 Nm</b></p> <p>1er serrage à l'angle _____ <b>60°</b></p> <p>2ème serrage à l'angle _____ <b>60°</b></p> <p><b>Nota:</b> après preuve à l'appui les vis peuvent être utilisées <b>3 fois</b>.</p>	<p>17. Serrare le viti dei cuscinetti di banco secondo le prescrizioni di serraggio riportate qui di seguito.</p> <p>Preserraggio</p> <p>BFM 1012 _____ <b>30 Nm</b></p> <p>BFM 1013 _____ <b>50 Nm</b></p> <p>I ripasso _____ <b>60°</b></p> <p>Il ripasso _____ <b>60°</b></p> <p><b>Nota:</b> Se è documentabile, le viti possono venire utilizzate <b>3 volte</b>.</p>

# Demontage und Montage, Motor komplett Disassembly and reassembly of complete engine Démontage et montage moteur complet Smontaggio e rimontaggio completo del motore

## Deutsch

## Werkstatthandbuch BFM 1012/E, BFM 1013/E

14. Anlauftringhälften mit Führungsnase am Paßlagerdeckel mit etwas Fett ankleben.

**Hinweis:** Anlaufringe müssen mit der Laufschichtseite zum Wangenspiegel der Kurbelwelle weisen.

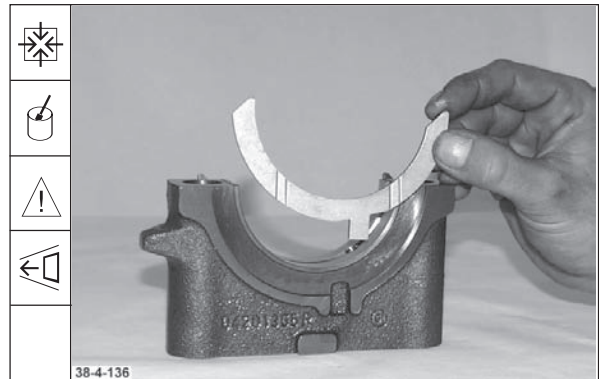

15. Paßlagerdeckel aufbauen

**Hinweis:** Lagerdeckel Nr. 1 ist schwungradseitig.  
Bei BFM 1012 müssen die Butzen zum Schwungrad weisen.

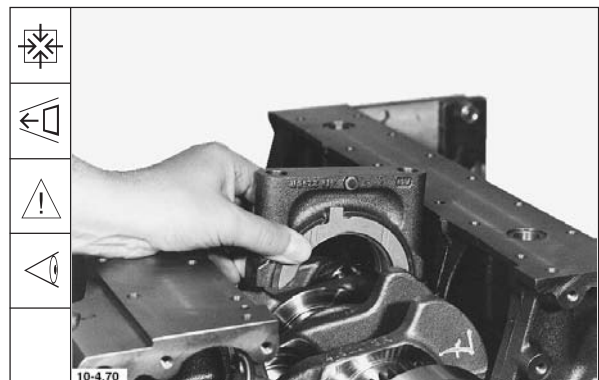

16. Hauptlagerdeckel entsprechend der Numerierung montieren.

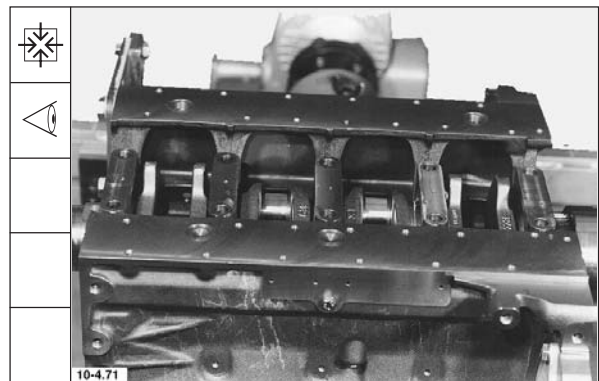

17. Hauptlagerschrauben nach Anziehvorschrift festdrehen.

Vorspannwert

BFM 1012 \_\_\_\_\_ **30 Nm**

BFM 1013 \_\_\_\_\_ **50 Nm**

1. Nachspannwert \_\_\_\_\_ **60°**

2. Nachspannwert \_\_\_\_\_ **60°**

**Hinweis:** Schrauben können bei Nachweisbarkeit **3x** verwendet werden.

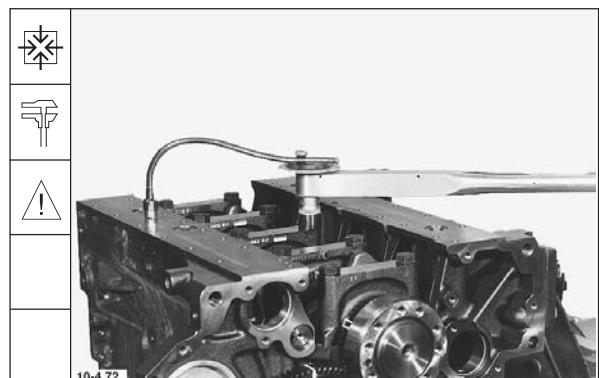

**Demontage und Montage, Motor komplett**  
**Disassembly and reassembly of complete engine**  
**Démontage et montage moteur complet**  
**Smontaggio e rimontaggio completo del motore**

Werkstatthandbuch BFM 1012/E, BFM 1013/E

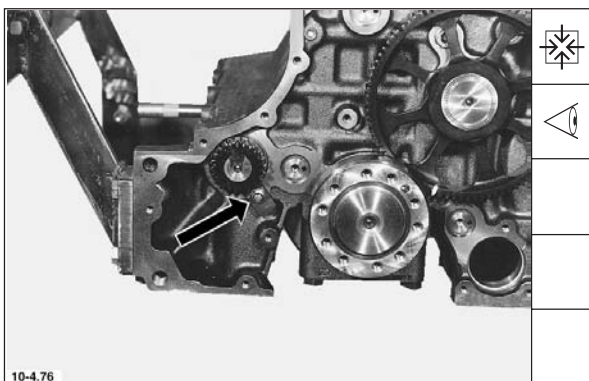
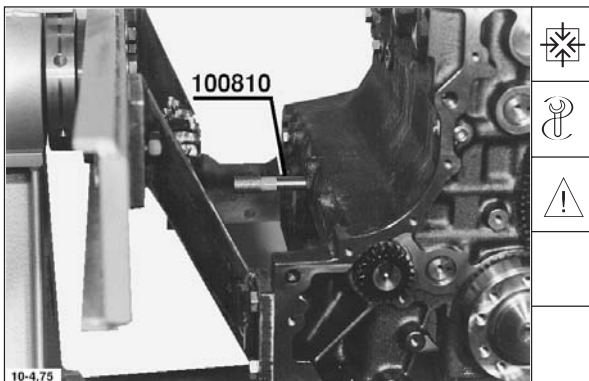
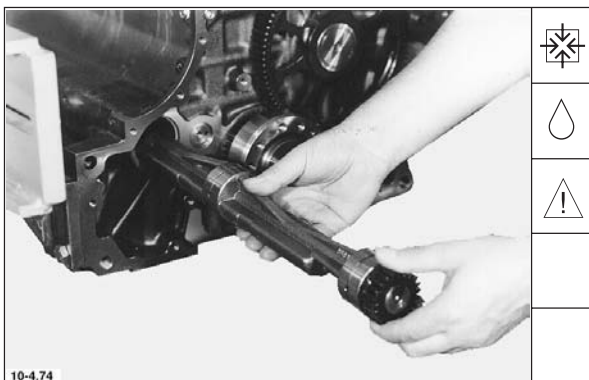
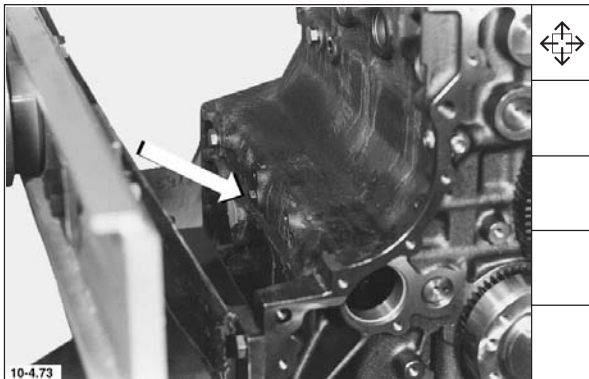

**Deutsch**

**Massenausgleichswellen BFM 1012**  
 (falls vorhanden)

Motor um 180° drehen.

18. Verschlußschrauben herausdrehen.

19. Massenausgleichswelle einbauen.

**Hinweis:** Die Gewichtslage muß zur Ölwanne-dichtfläche weisen.

20. Einstellbolzen für Massenausgleichswelle in das Kurbelgehäuse bis zum Anschlag einschrauben.

**Hinweis:** Bohrung der Massenausgleichswelle muß mit der Bohrung im Kurbelwellengehäuse in Überdeckung stehen.

21. Anlaufscheibe anbauen und zur Wellenachse ausrichten.



**Demontage und Montage, Motor komplett**  
**Disassembly and reassembly of complete engine**  
**Démontage et montage moteur complet**  
**Smontaggio e rimontaggio completo del motore**

English	Français	Italiano
<b>Mass balancing shafts BFM 1012</b> (if any)	<b>Arbres à masse d'équilibrage BFM 1012</b> (selon l'équipement du moteur)	<b>Albero delle masse controrotanti BFM 1012</b> (qualora presente)
Turn engine by 180°.	Virer le moteur de 180°.	Girare il motore di 180°.
18. Turn out screw plugs.	18. Dévisser et sortir les vis filetées.	18. Svitare e togliere le viti.
19. Introduce mass balancing shaft.	19. Monter l'arbre à masses d'équilibrage.	19. Montare l'albero delle masse controrotanti.
<b>Note:</b> The weights must be positioned towards oil pan sealing surface.	<b>Nota:</b> les poids doivent être orientés vers le plan d'étanchéité du carter d'huile.	<b>Nota:</b> La posizione dei pesi deve essere orientata verso la superficie di tenuta della coppa dell'olio.
20. Screw adjusting pin for mass balancing shaft into crankcase as far as it will go.	20. Visser la pige de réglage de l'arbre à masses d'équilibrage dans le bloc moteur jusqu'en position de butée.	20. Avvitare fino a battuta nell'incastellatura il perno di regolazione dell'albero delle masse controrotanti.
<b>Note:</b> Bore of mass balancing shaft must be in line with bore in crankcase.	<b>Nota:</b> l'alésage de l'arbre à masses d'équilibrage doit correspondre à l'alésage du bloc moteur.	<b>Nota:</b> Il foro nell'albero delle masse controrotanti deve coincidere col foro nell'incastellatura.
21. Fit thrust washer and align relative to shaft axis.	21. Monter la flasque de butée en l'orientant vers l'axe de l'arbre.	21. Montare la rondella di guida ed allinearla con l'asse dell'albero

**Demontage und Montage, Motor komplett**  
**Disassembly and reassembly of complete engine**  
**Démontage et montage moteur complet**  
**Smontaggio e rimontaggio completo del motore**

English	Français	Italiano
22. Tighten bolt with a torque of <b>29 Nm</b> .	22. Serrer la vis au couple de <b>29 Nm</b> .	22. Serrare la vite con una coppia di <b>29 Nm</b> .
23. Turn crankshaft and bring cyl. 1 to TDC. TDC position is reached when the crankshaft marking coincides with the centerline of crankshaft and camshaft.	23. Mettre le vilebrequin cyl. 1 en position de PMH. Le PMH est atteint quand le repère sur le vilebrequin se trouve à l'intersection entre les points milieu du vilebrequin et de l'arbre à cames.	23. Virare l'albero a gomiti fino a portare il cilindro 1 sul PMS. Il PMS è raggiunto allorchè il contrassegno sull'albero a gomiti si trova sulla linea di collegamento dei centri dell'albero a gomiti e dell'albero a camme.
24. Position idler gear and press down lightly until it meshes with the crankshaft gear.	24. Mettre en place le pignon intermédiaire et l'enfoncer légèrement dans l'engrènement du pignon du vilebrequin.	24. Posizionare l'ingranaggio intermedio e spingerlo leggermente fino a farlo ingranare nell'ingranaggio dell'albero a gomiti.
25. Mark opposite teeth.	25. Repérer les dents se trouvant en regard les unes des autres.	25. Contrassegnare i denti che si trovano uno di fronte all'altro.



**Deutsch**

**Werkstatthandbuch BFM 1012/E, BFM 1013/E**

22. Schraube mit einem Drehmoment von **29 Nm** festdrehen.

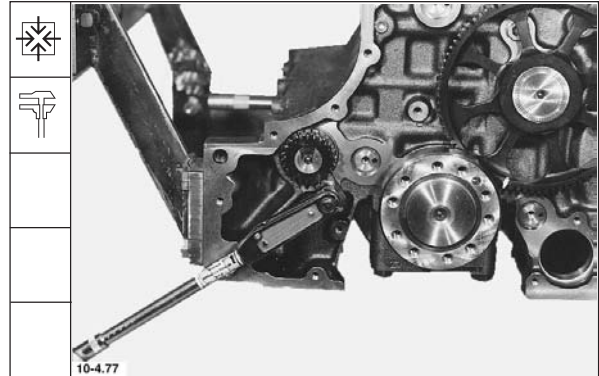

23. Kurbelwelle Zyl. 1 auf OT stellen.  
OT ist dann erreicht, wenn die Markierung auf der Kurbelwelle in Verbindungslinie der Mittelpunkte von Kurbelwelle und Nockenwelle liegt.

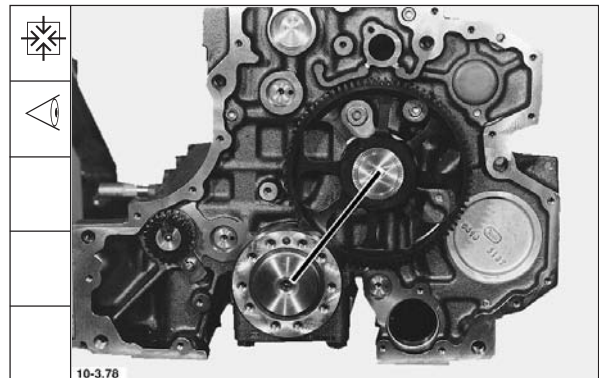

24. Zwischenrad einsetzen und leicht in den Eingriff des Zahnrades der Kurbelwelle drücken.

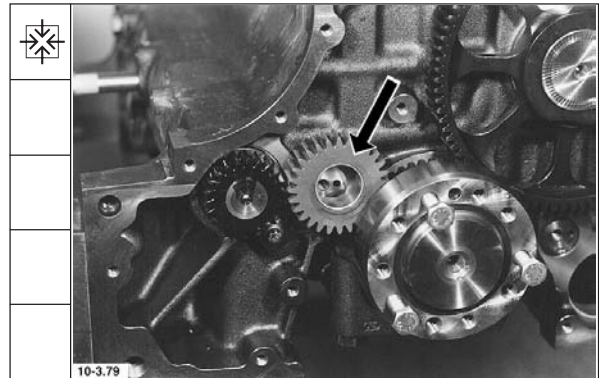

25. Die gegenüberliegenden Zähne markieren.

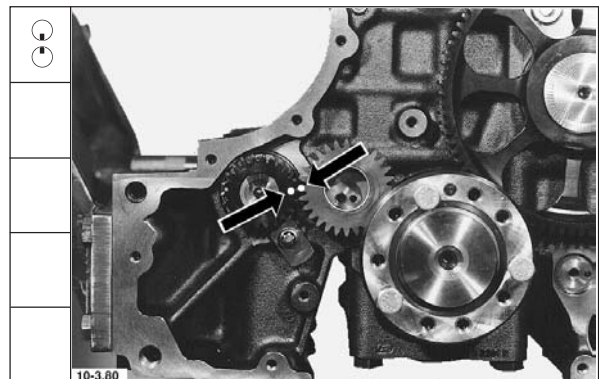

**Demontage und Montage, Motor komplett**  
**Disassembly and reassembly of complete engine**  
**Démontage et montage moteur complet**  
**Smontaggio e rimontaggio completo del motore**

**Werkstatthandbuch BFM 1012/E, BFM 1013/E**

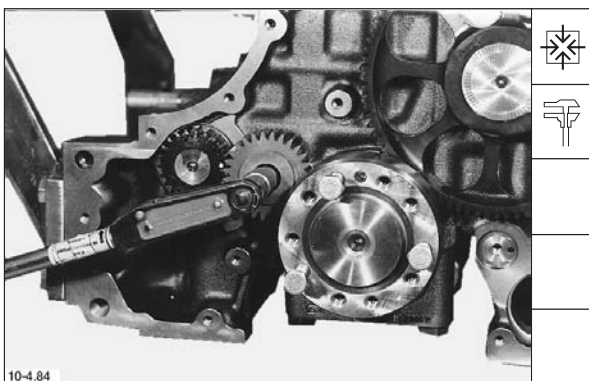
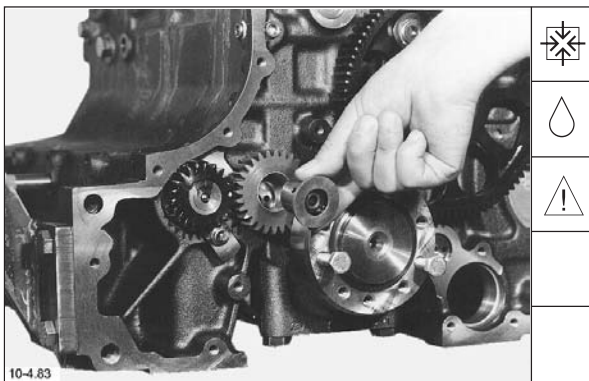
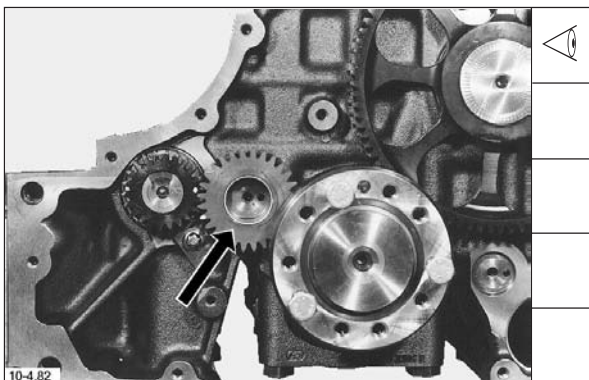
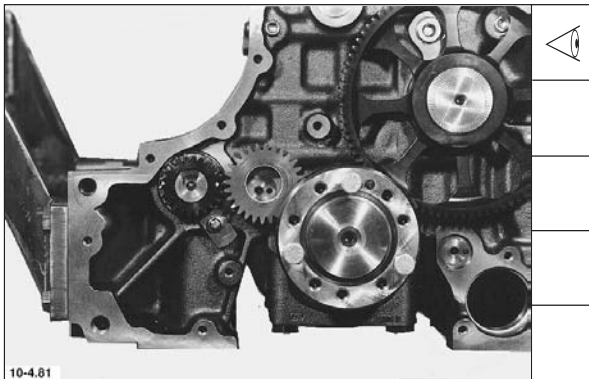

**Deutsch**

26. Kurbelwelle im Uhrzeigersinn drehen, bis 3 Zähne übergesprungen sind.

27. Kurbelwelle entgegen dem Uhrzeigersinn drehen, bis Bohrungen in Überdeckung stehen.

28. Lagerzapfen einsetzen.

**Hinweis:** Durch leichtes Hin- und Herdrehen der Kurbelwelle prüfen, ob Lagerzapfen in der Bohrung zentriert ist.

29. Schraube einsetzen und mit einem Drehmoment von **29 Nm** festdrehen.

**Demontage und Montage, Motor komplett**  
**Disassembly and reassembly of complete engine**  
**Démontage et montage moteur complet**  
**Smontaggio e rimontaggio completo del motore**

English	Français	Italiano
26. Turn crankshaft in clockwise direction until 3 teeth have engaged.	26. Virer le vilebrequin dans le sens horaire jusqu'à ce que 3 dents sautent.	26. Virare l'albero a gomiti in senso orario fino a creare uno sfasamento di 3 denti.
27. Turn crankshaft in anti-clockwise direction until bores are in line.	27. Virer le vilebrequin dans le sens antihoraire jusqu'à ce que les alésages correspondent.	27. Virare l'albero a gomiti in senso orario fino a far coincidere i fori.
28. Insert bearing journal.  <b>Note:</b> Check whether bearing journal is centered in bore by slightly turning crankshaft back and forth.	28. Mettre en place le tourillon.  <b>Nota:</b> déplacer légèrement par un mouvement de va-et-vient le vilebrequin pour vérifier si le tourillon est bien centré dans l'alésage.	28. Introdurre il perno di supporto.  <b>Nota:</b> Ruotare leggermente avanti ed indietro l'albero a gomiti, per controllare se il perno di supporto è ben centrato nel foro.
29. Insert bolt and tighten with a torque of <b>29 Nm</b> .	29. Placer la vis et la serrer au couple de <b>29 Nm</b> .	29. Inserire la vite e serrarla con una coppia di <b>29 Nm</b> .

**Demontage und Montage, Motor komplett**  
**Disassembly and reassembly of complete engine**  
**Démontage et montage moteur complet**  
**Smontaggio e rimontaggio completo del motore**

English	Français	Italiano
<p>30. Introduce 2nd mass balancing shaft.</p> <p><b>Note:</b> The weights must be positioned towards oil pan sealing surface.</p>	<p>30. Monter le 2ème arbre à masses d'équilibrage.</p> <p><b>Nota:</b> les poids doivent être orientés vers le plan de joint du carter d'huile.</p>	<p>30. Montare il secondo albero delle masse contrrotanti.</p> <p><b>Nota:</b> La posizione dei pesi deve essere orientata verso la superficie di tenuta della coppa dell'olio.</p>
<p>31. Screw adjusting pin for mass balancing shaft into crankcase as far as it will go.</p> <p><b>Note:</b> Bore of mass balancing shaft must be in line with bore in crankcase.</p>	<p>31. Visser la pìge de réglage de l'arbre à masses d'équilibrage dans le bloc moteur jusqu'en position de butée.</p> <p><b>Nota:</b> l'alésage de l'arbre à masses d'équilibrage doit correspondre à l'alésage du bloc moteur.</p>	<p>31. Avvitare fino a battuta nell'incastellatura il perno di regolazione dell'albero delle masse contrrotanti.</p> <p><b>Nota:</b> Il foro nell'albero delle masse contrrotanti deve coincidere col foro nell'incastellatura.</p>
<p>32. Fit thrust washer and align relative to shaft axis.</p>	<p>32. Monter la flasque de butée en l'orientant vers l'axe de l'arbre.</p>	<p>32. Montare la rondella di guida ed allinearla con l'asse dell'albero</p>
<p>33. Tighten bolt with a torque of <b>29 Nm</b>.</p>	<p>33. Serrer la vis au couple de <b>29 Nm</b>.</p>	<p>33. Serrare la vite con una coppia di <b>29 Nm</b>.</p>

**Deutsch**

**Werkstatthandbuch BFM 1012/E, BFM 1013/E**

30. 2. Massenausgleichswelle einbauen.

**Hinweis:** Die Gewichtslage muß zur Ölwanne-dichtfläche weisen.



31. Einstellbolzen für Massenausgleichswelle in das Kurbelgehäuse bis zum Anschlag einschrauben.

**Hinweis:** Bohrung der Massenausgleichswelle muß mit der Bohrung im Kurbelgehäuse in Überdeckung stehen.

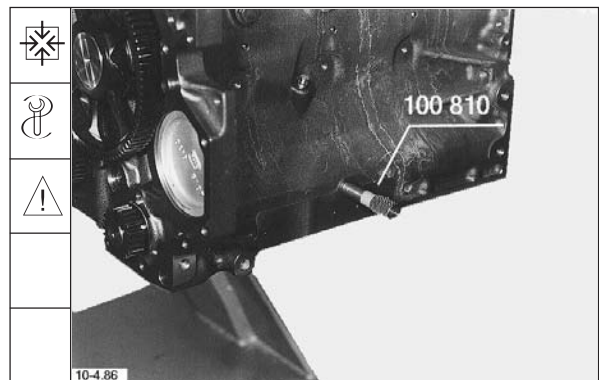

32. Anlaufscheibe anbauen und zur Wellenachse ausrichten.

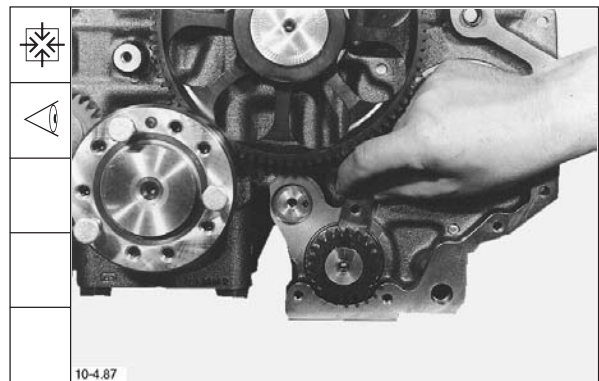

33. Schraube mit einem Drehmoment von **29 Nm** festdrehen.

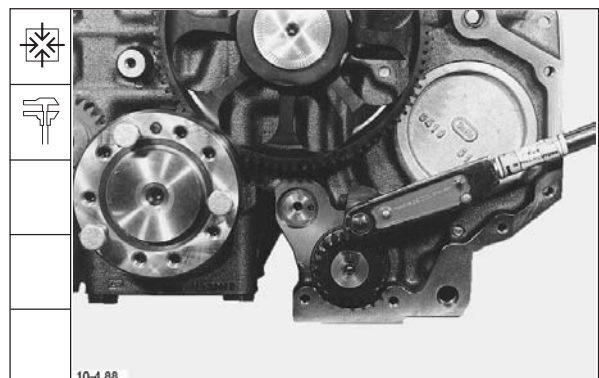



**Demontage und Montage, Motor komplett**  
**Disassembly and reassembly of complete engine**  
**Démontage et montage moteur complet**  
**Smontaggio e rimontaggio completo del motore**

Werkstatthandbuch BFM 1012/E, BFM 1013/E

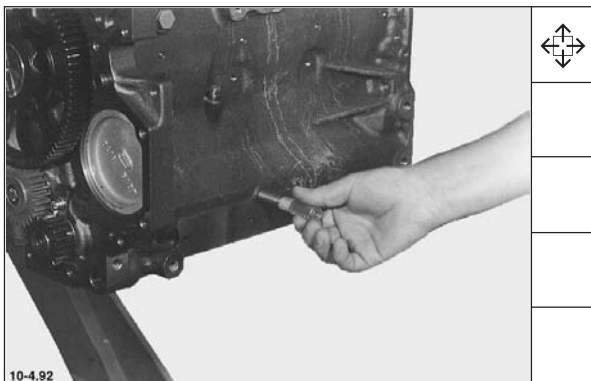
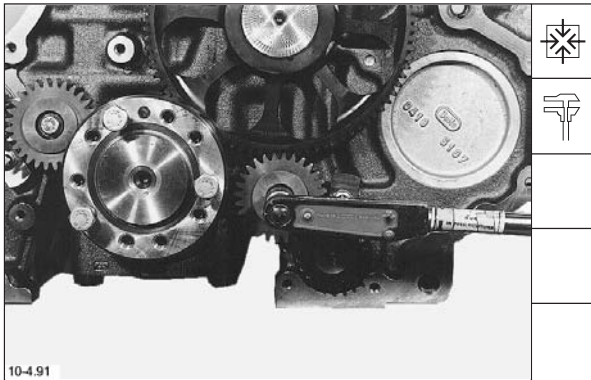
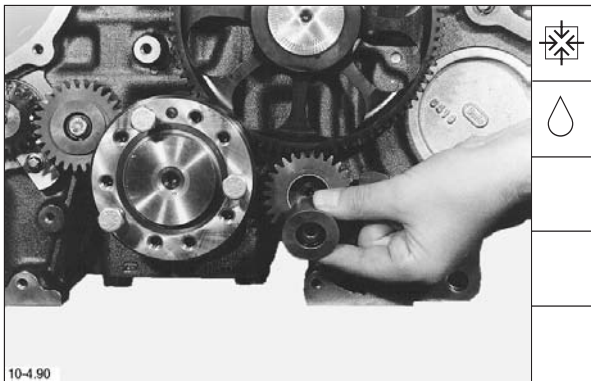
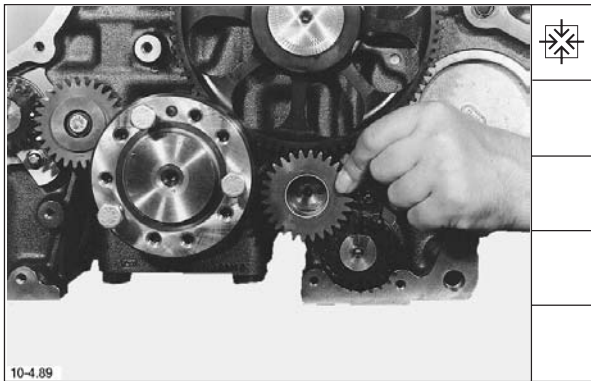

Deutsch

34. Zwischenrad so einsetzen, daß Bohrungen in Überdeckung stehen.

35. Lagerzapfen einsetzen.

36. Schraube einsetzen und mit einem Drehmoment von **29 Nm** festdrehen.

37. Beide Einstellbolzen entfernen.

**Demontage und Montage, Motor komplett**  
**Disassembly and reassembly of complete engine**  
**Démontage et montage moteur complet**  
**Smontaggio e rimontaggio completo del motore**

English	Français	Italiano
34. Insert idler gear so that bores are in line.	34. Placer le pignon intermédiaire de manière à ce que les alésages correspondent.	34. Posizionare l'ingranaggio intermedio in modo che i fori coincidano.
35. Insert bearing journal.	35. Mettre en place le tourillon.	35. Inserire il perno di supporto.
36. Insert bolt and tighten with a torque of <b>29 Nm</b> .	36. Placer la vis et serrer au couple de <b>29 Nm</b> .	36. Inserire la vite e serrarla con una coppia di <b>29 Nm</b> .
37. Remove both adjusting pins.	37. Oter les deux piges de calage.	37. Smontare ambedue i perni di regolazione.

**Demontage und Montage, Motor komplett**  
**Disassembly and reassembly of complete engine**  
**Démontage et montage moteur complet**  
**Smontaggio e rimontaggio completo del motore**

English	Français	Italiano
38. Cover up bores with new Cu seals.	38. Obturer les alésages avec des bagues d'étanchéité Cu neuves.	38. Chiudere i fori con nuovi anelli di tenuta di rame.
<b>Drive gear/governor</b>	<b>Pignon d'entraînement/régulateur</b>	<b>Ingranaggio di comando/regolatore</b>
39. Insert governor drive gear complete with bearing journal.	39. Mettre en place le pignon d'entraînement du régulateur avec le tourillon.	39. Montare l'ingranaggio di comando per il regolatore col suo perno di supporto.
40. Insert bolt and tighten with a torque of <b>21 Nm</b> .	40. Placer la vis et la serrer au couple de <b>21 Nm</b> .	40. Inserire la vite e serrarla con una coppia di <b>21 Nm</b> .
<b>Control rod</b>	<b>Crémaillère</b>	<b>Asta a cremagliera</b>
41. Fit control rod complete with guide sleeve.	41. Monter la crémaillère avec la douille de guidage.	41. Montare l'asta a cremagliera con la sua boccia di guida.



Deutsch

Werkstatthandbuch BFM 1012/E, BFM 1013/E

38. Bohrungen mit neuen Cu-Dichtringen verschließen.

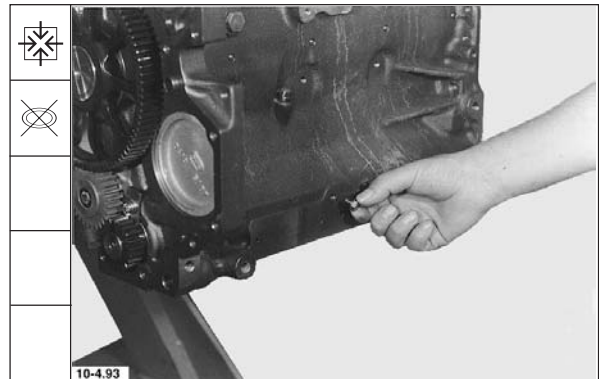

Antriebsrad/Regler

39. Antriebsrad für Regler mit Lagerzapfen einsetzen.

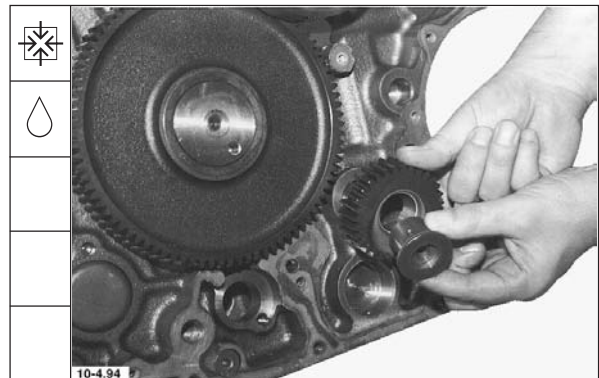

40. Schraube einsetzen und mit einem Drehmoment von **21 Nm** festdrehen.



Regelstange

41. Regelstange mit Führungsbuchse einbauen.



**Demontage und Montage, Motor komplett**  
**Disassembly and reassembly of complete engine**  
**Démontage et montage moteur complet**  
**Smontaggio e rimontaggio completo del motore**

**Werkstatthandbuch BFM 1012/E, BFM 1013/E**

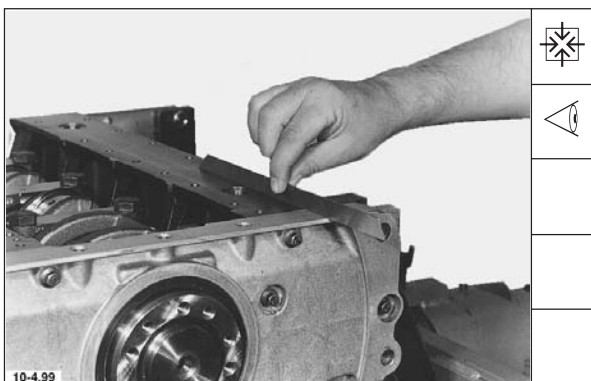
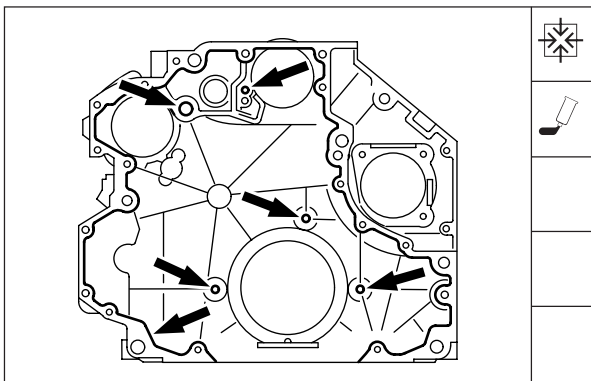
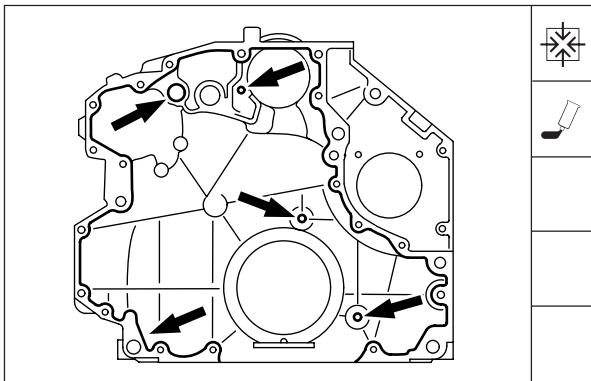
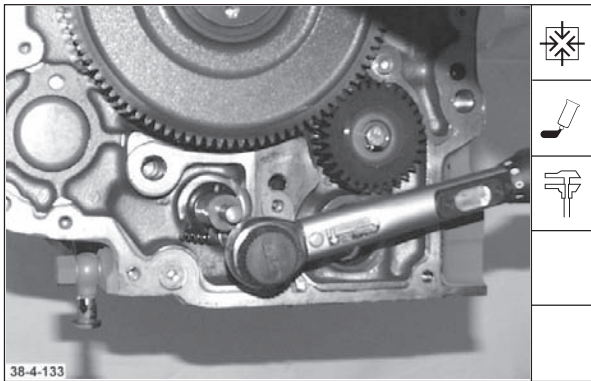

**Deutsch**

42. Schraube mit Sicherungsmittel **Deutz DW 71** einsetzen und mit einem Drehmoment von **10 + 2 Nm** festdrehen.

**Räderkastendeckel**

43. Dichtfläche des Räderkastendeckels mit Dichtmittel **Deutz DW 67** bestreichen.

BFM 1012

BFM 1013

44. Räderkastendeckel anbauen. Schrauben beidrehen und Räderkastendeckel zur Ölwanndichtfläche ausrichten.

**Demontage und Montage, Motor komplett**  
**Disassembly and reassembly of complete engine**  
**Démontage et montage moteur complet**  
**Smontaggio e rimontaggio completo del motore**

English	Français	Italiano
<p>42. Apply <b>Deutz DW 71</b> locking compound to bolt and tighten with a torque of <b>10 + 2 Nm</b>.</p>	<p>42. Monter la vis à la pâte de frein <b>DEUTZ DW 71</b> et la serrer au couple de <b>10 + 2 Nm</b>.</p>	<p>42. Montare la vite facendo uso del bloccante <b>Deutz DW 71</b> e serrarla con una coppia di <b>10 + 2 Nm</b>.</p>
<p><b>Timing chest cover</b></p>	<p><b>Couvercle de carter de distribution</b></p>	<p><b>Coperchio della scatola della distribuzione</b></p>
<p>43. Apply <b>Deutz DW 67</b> sealing compound to sealing surface of timing chest cover.</p>	<p>43. Enduire le produit <b>Deutz DW 67</b> la surface d'étanchéité du couvercle de la distribution.</p>	<p>43. Spalmare con ermetico <b>Deutz DW 67</b> le superfici di tenuta del coperchio della scatola di distribuzione.</p>
<p>BFM 1012</p>	<p>BFM 1012</p>	<p>BFM 1012</p>
<p>BFM 1013</p>	<p>BFM 1013</p>	<p>BFM 1013</p>
<p>44. Mount timing chest cover. Start bolts and align timing chest cover relative to oil pan sealing surface.</p>	<p>44. Monter le couvercle de la distribution. Server les vis à la main et aligner le couvercle de la distribution par rapport au plan d'appui du carter d'huile.</p>	<p>44. Montare il coperchio della scatola di distribuzione. Avvitare a mano le viti ed allineare il coperchio della scatola di distribuzione con la superficie di tenuta della coppa dell'olio.</p>

**Demontage und Montage, Motor komplett**  
**Disassembly and reassembly of complete engine**  
**Démontage et montage moteur complet**  
**Smontaggio e rimontaggio completo del motore**

English	Français	Italiano
45. Tighten bolts with a torque of <b>21 ± 2 Nm.</b>	45. Serrer les vis au couple de <b>21 ± 2 Nm.</b>	45. Serrare le viti con una coppia di <b>21 ± 2 Nm.</b>
<b>Front cover</b>	<b>Couvercle avant</b>	<b>Coperchio anteriore</b>
46. Lightly oil rotors in front cover.	46. Huiler légèrement les rotors du couvercle avant.	46. Oliare leggermente i rotori nel coperchio anteriore.
47. Stick gasket to front cover using some grease.	47. Coller le joint du couvercle avant avec un peu de graisse.	47. Incollare con un po' di grasso la guarnizione sul coperchio anteriore.
Turn engine by 180°. Oil pan sealing surface must point downward.	Virer le moteur de 180°. Le plan de joint du carter d'huile doit être dirigé vers le bas.	Girare il motore di 180°. La superficie di tenuta della coppa dell'olio deve essere rivolta verso il basso.
48. Position rotor relative crankshaft.	48. Positionner le rotor par rapport au vilebrequin.	48. Posizionare il rotore verso l'albero a gomiti.

**Deutsch**

**Werkstatthandbuch BFM 1012/E, BFM 1013/E**

45. Schrauben mit einem Drehmoment von  $21 \pm 2$  Nm festdrehen.

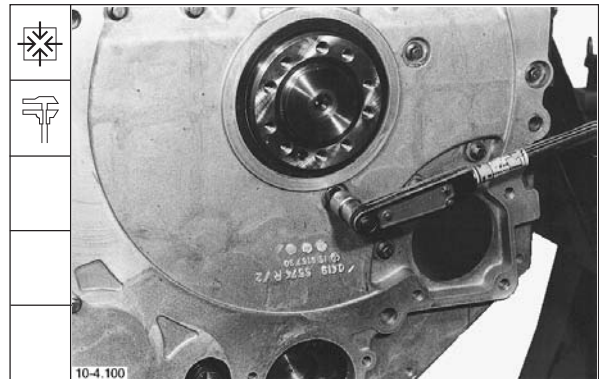

**Vorderer Deckel**

46. Rotoren im vorderen Deckel leicht ölen.



47. Dichtung für vorderen Deckel mit etwas Fett ankleben.

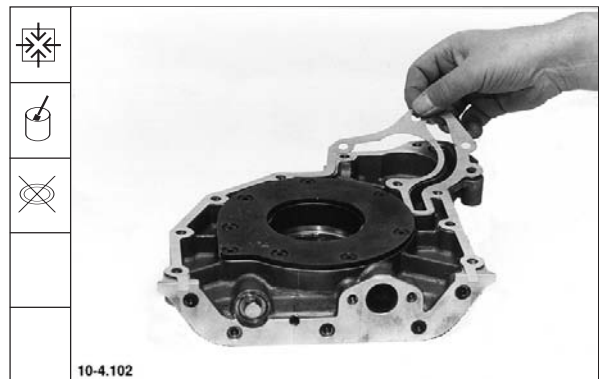

Motor 180° drehen. Ölwanne dichtfläche muß nach unten weisen.

48. Rotor zur Kurbelwelle positionieren.

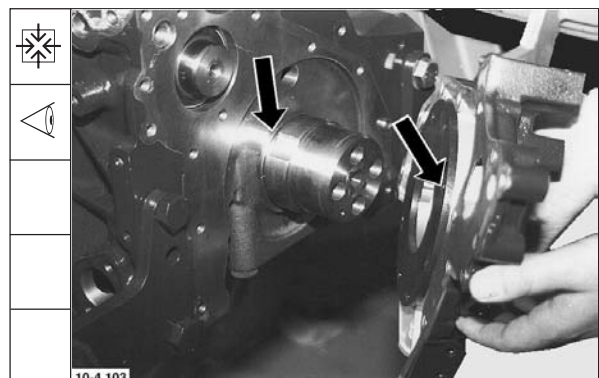

**Demontage und Montage, Motor komplett**  
**Disassembly and reassembly of complete engine**  
**Démontage et montage moteur complet**  
**Smontaggio e rimontaggio completo del motore**

**Werkstatthandbuch BFM 1012/E, BFM 1013/E**

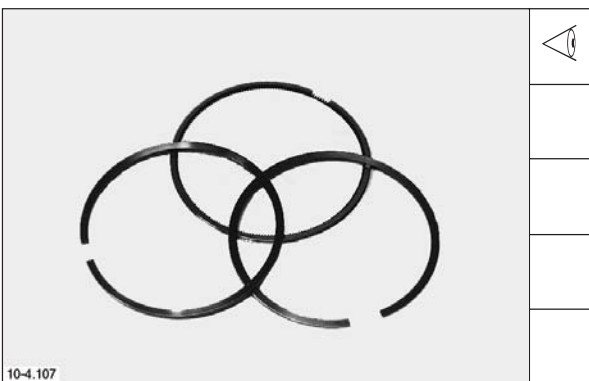
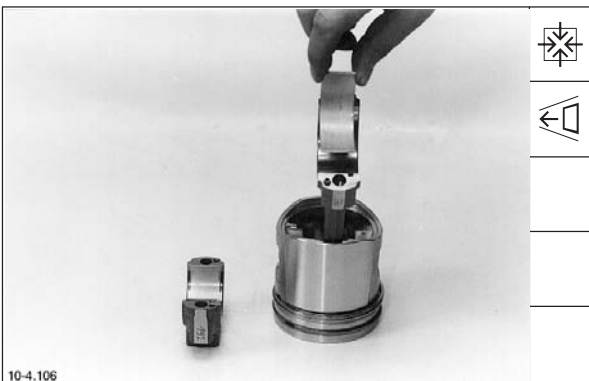
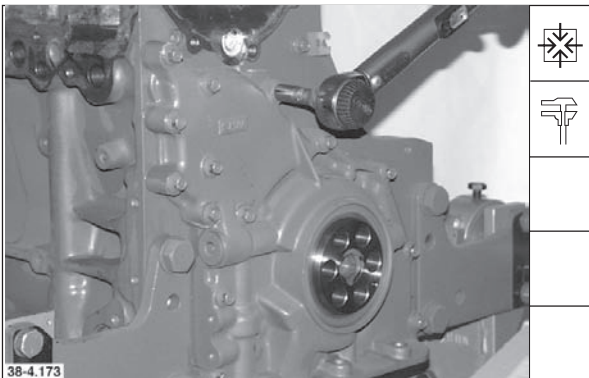
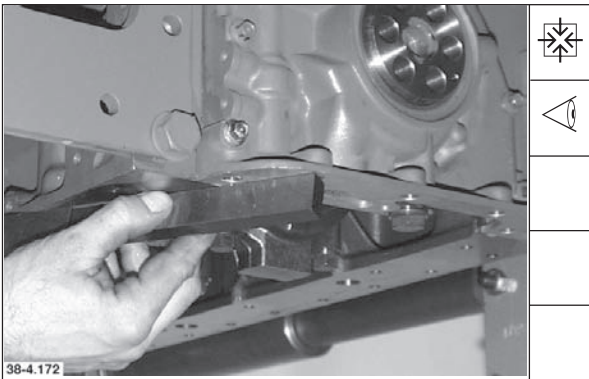

**Deutsch**

49. Vorderen Deckel anbauen, Deckel nach oben drücken und zur Ölwanne dichtfläche ausrichten. Schrauben leicht andrehen.

50. Schrauben für vorderen Deckel mit einem Drehmoment von **21 ± 2 Nm** festdrehen.

**Kolben mit Pleuel**

51. Pleuellagerschalen in Pleuelstange einbauen.

52. Kolbenringstöße **90-120°** zueinander versetzt anordnen.

**Demontage und Montage, Motor komplett**  
**Disassembly and reassembly of complete engine**  
**Démontage et montage moteur complet**  
**Smontaggio e rimontaggio completo del motore**

English	Français	Italiano
49. Mount front cover, press cover upward and align relative to oil pan sealing surface. Start bolts.	49. Monter le couvercle avant, le serrer vers le haut et l'aligner par rapport au plan de joint du carter d'huile. Serrer les vis modérément.	49. Montare il coperchio anteriore, spingerlo verso l'alto ed allinearlo con la superficie di tenuta della coppa dell'olio. Avvitare leggermente a mano le viti.
50. Tighten bolts for front cover with a torque of <b>21 ± 2 Nm</b> .	50. Serrer les vis du couvercle avant au couple de <b>21 ± 2 Nm</b> .	50. Serrare le viti del coperchio anteriore con una coppia di <b>21 ± 2 Nm</b> .
<b>Piston complete with connecting rod</b>	<b>Ensemble piston-bielle</b>	<b>Pistone con biella</b>
51. Insert bearing shells in connecting rod.	51. Monter les coussinets dans la bielle.	51. Montare nella biella i semi gusci.
52. Piston ring gaps must be staggered by <b>90-120°</b> .	52. Tiercer les coupes de segment de <b>90-120°</b> .	52. Sfasare tra di loro di <b>90-120°</b> i tagli delle fasce elastiche.

**Demontage und Montage, Motor komplett**  
**Disassembly and reassembly of complete engine**  
**Démontage et montage moteur complet**  
**Smontaggio e rimontaggio completo del motore**

English	Français	Italiano
<p>53. Introduce piston complete with connecting rod into crankcase with integrated cylinder liners.</p> <p><b>Note:</b> Flywheel symbol must point towards flywheel.</p>	<p>53. Insérer le piston complet et la bielle dans le bloc moteur.</p> <p><b>Nota:</b> le symbole du volant doit être orienté vers le volant.</p>	<p>53. Infilare nell'incastellatura il pistone assieme alla biella</p> <p><b>Nota:</b> Il simbolo del volante sul pistone deve essere rivolto verso il volante.</p>
<p>54. Press connecting rod against crankpin. Fit pertinent big end bearing cap.</p>	<p>54. Enfoncer la bielle en exerçant une pression contre le maneton. Monter le chapeau de bielle correspondant.</p>	<p>54. Premere la biella contro il perno di manovella . Montare il corrispondente cappello di biella.</p>
<p>55. Tighten <b>new conrod bolts</b> in accordance with specification.</p> <p>Initial tightening torque <b>30 Nm</b>            1st tightening angle <b>60°</b>            2nd tightening angle</p> <p>BFM 1012 <b>30°</b>            BFM 1013 <b>60°</b></p>	<p>55. Serrer les <b>vis de bielle neuves</b> selon les consignes de serrage.</p> <p>Serrage d'approche <b>30 Nm</b>            1. Serrage à l'angle <b>60°</b>            2. Serrage à l'angle</p> <p>BFM 1012 <b>30°</b>            BFM 1013 <b>60°</b></p>	<p>55. Bloccare i <b>nuovi bulloni di biella</b> in base alle prescrizioni di serraggio sottostanti:</p> <p>Preserraggio <b>30 Nm</b>            l'angolo di ripasso <b>60°</b>            Il angolo di ripasso:</p> <p>BFM 1012 <b>30°</b>            BFM 1013 <b>60°</b></p>
<p>56. Check that connecting rods can be easily moved back and forth on the crankpin.</p> <p><b>Note:</b> Turn engine by 180°.</p>	<p>56. Contrôler les bielles: elles doivent se déplacer légèrement au niveau du maneton.</p> <p><b>Nota:</b> virer le moteur de 180°.</p>	<p>56. Controllare che le bielle possano muoversi con facilità avanti ed indietro attorno ai perni di manovella.</p> <p><b>Nota:</b> Girare il motore di 180°.</p>



**Demontage und Montage, Motor komplett**  
**Disassembly and reassembly of complete engine**  
**Démontage et montage moteur complet**  
**Smontaggio e rimontaggio completo del motore**

**Deutsch**

**Werkstatthandbuch BFM 1012/E, BFM 1013/E**

53. Kolben komplett mit Pleuel in das Zylinderkurbelgehäuse einschieben.

**Hinweis:** Schwungradsymbol muß zum Schwungrad weisen.

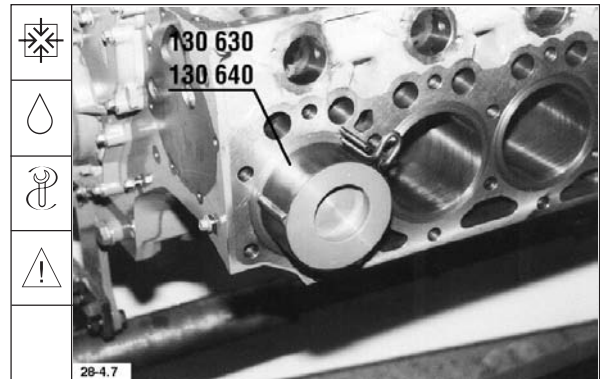

54. Pleuelstange gegen den Hubzapfen drücken. Dazugehörigen Pleuellagerdeckel montieren.

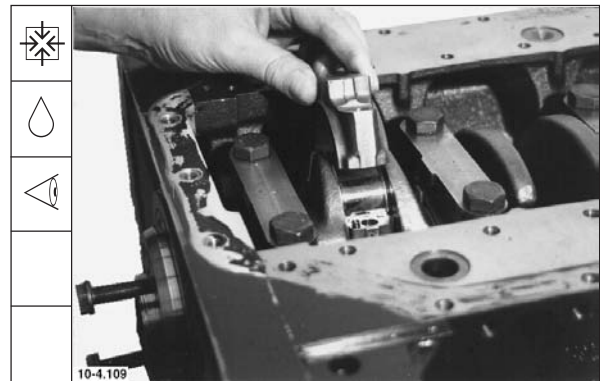

55. **Neue Pleuelschrauben** nach Anziehvorschrift festdrehen.

Vorspannwert _____	<b>30 Nm</b>
1. Nachspannwinkel _____	<b>60°</b>
2. Nachspannwinkel	
BFM 1012 _____	<b>30°</b>
BFM 1013 _____	<b>60°</b>

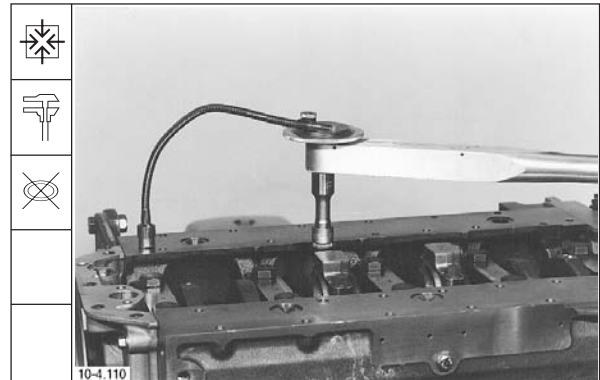

56. Pleuelstangen kontrollieren, ob sie sich auf dem Hubzapfen leicht verschieben lassen.

**Hinweis:** Motor um 180° drehen.

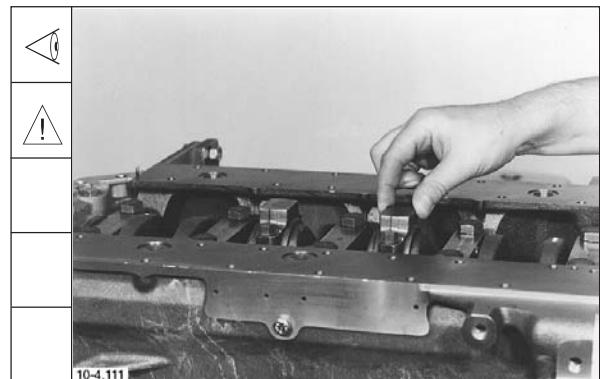

**Demontage und Montage, Motor komplett**  
**Disassembly and reassembly of complete engine**  
**Démontage et montage moteur complet**  
**Smontaggio e rimontaggio completo del motore**

**Werkstatthandbuch BFM 1012/E, BFM 1013/E**

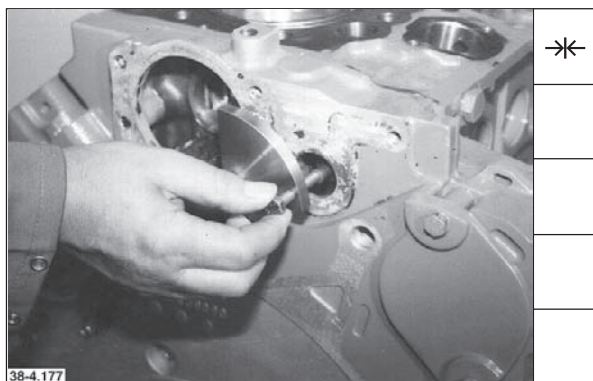
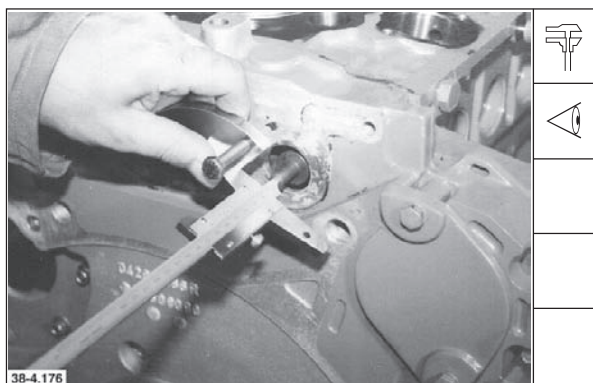
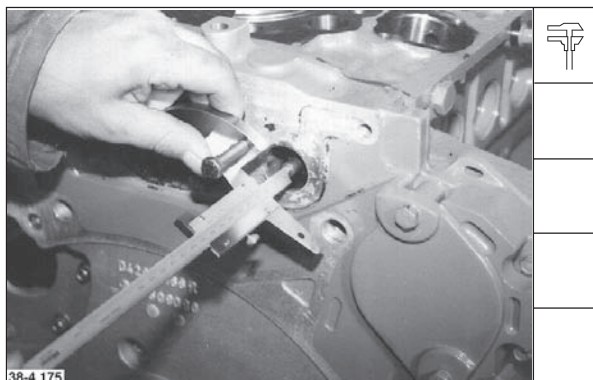
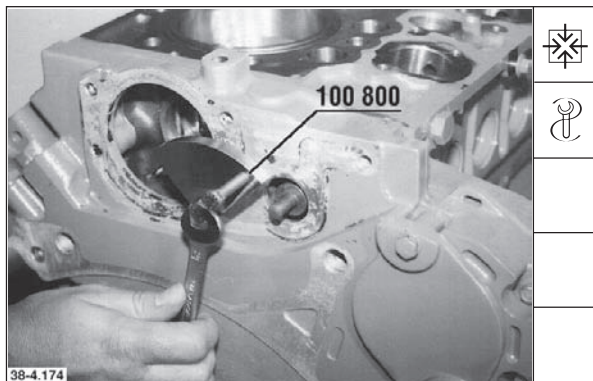

**Deutsch**

**Einspritzpumpen einbauen**

**Regelstangenweg messen ohne Einspritzpumpen**

57. Feststellvorrichtung für Regelstange anbauen.

58. Von Vorrichtung bis zur Stopstellung der Regelstange messen.

58.1 Von Vorrichtung bis zur Startstellung der Regelstange messen.

Differenz zur Stopstellung ergibt Regelstangenweg.

Beispiel:  
 Stopstellung = 30,7 mm  
 Startstellung = 13,4 mm  
 Regelstangenweg = **17,3 mm**

Sollmaß = **17,0 mm - 17,5 mm**

59. Vorrichtung drehen. Regelstange mit Rändel-Feststellschraube von Hand in Stopstellung drücken.

**Demontage und Montage, Motor komplett**  
**Disassembly and reassembly of complete engine**  
**Démontage et montage moteur complet**  
**Smontaggio e rimontaggio completo del motore**

English	Français	Italiano
<b>Installing injection pumps</b>	<b>Monter les pompes d'injection</b>	<b>Montare le pompe di iniezione</b>
<b>Gauging control rod travel without injection pumps installed</b>	<b>Mesurer le déplacement de la crémaillère sans pompes d'injection.</b>	<b>Misurare la corsa dell'asta a cremagliera senza le pompe d'iniezione.</b>
57. Fit control rod locking device.	57. Monter le dispositif de fixation de la crémaillère.	57. Montare il dispositivo di bloccaggio per l'asta a cremagliera.
58. Gauge from locking device to stop position of control rod.	58. Mesurer la distance entre le dispositif et la position stop de la crémaillère.	58. Misurare la distanza tra il suddetto dispositivo e la posizione di stop dell'asta a cremagliera.
58.1 Gauge from locking device to start position of control rod.	58.1 Mesurer la distance entre le dispositif et la position de démarrage de la crémaillère.	58.1 Misurare la distanza tra il suddetto dispositivo e la posizione di avviamento dell'asta a cremagliera.
Difference between start and stop positions equals control rod travel.	La différence par rapport à la position de stop est le déplacement de la crémaillère.	Dalla differenza tra la posizione di stop e la posizione di avviamento si ottiene la corsa dell'asta a cremagliera.
Example: stop position = 30.7 mm start position = 13.4 mm control rod travel = <b>17.3 mm</b> Specified dimension = <b>17.0 mm</b> - <b>17.5 mm</b>	Exemple: position stop = 30,7 mm position démarrage = 13,4 mm déplacement crémaillère = <b>17,3 mm</b> Valeur de consigne = <b>17,0 mm</b> - <b>17,5 mm</b>	Esempio: posizione di stop = 30,7 mm posizione di avviamento = 13,4 mm Corsa dell'asta a crem. = <b>17,3 mm</b>  Valore nomin. = <b>17,0 mm - 17,5 mm</b>
59. Turn locking device. Press control rod in stop position by hand with knurled-head setscrew.	59. Tourner le dispositif. A la main enfoncer la crémaillère avec la vis d'immobilisation en position de stop.	59. Girare il dispositivo di bloccaggio. Spingere manualmente l'asta a cremagliera nella posizione di stop per mezzo della vite a testa zigrinata.

**Demontage und Montage, Motor komplett**  
**Disassembly and reassembly of complete engine**  
**Démontage et montage moteur complet**  
**Smontaggio e rimontaggio completo del motore**

English	Français	Italiano
60. Fit graduated disc to flywheel flange.	60. Monter le disque gradué sur la bride du volant moteur.	60. Montare il disco graduato sulla flangia del volano.
61. Fit pointer.	61. Monter l'index gradué.	61. Montare l'indicatore.
<b>Determining TDC of piston pertaining to injection pump to be timed.</b>	<b>Calculer le PMH du piston de la pompe d'injection à caler.</b>	<b>Determinare il PMS del pistone corrispondente alla pompa d'iniezione che si deve mettere a punto.</b>
62. Position TDC measuring bar together with spacing washers. Turn crankshaft in direction of engine rotation until pointer of dial gauge has reached its reversal point. Set dial gauge to „0“.	62. Mettre en place la barre de mesure du PMH avec des plaquettes d'écartement. Virer le vilebrequin dans le sens de rotation du moteur jusqu'à ce que l'index du comparateur atteigne son point d'inversion. Régler le comparateur sur „0“.	62. Posizionare la mensola per la misurazione del PMS. Virare l'albero a gomiti nel senso di rotazione del motore fino a quando la lancetta del comparatore ha raggiunto il suo punto di inversione. Regolare il comparatore sullo "0".
63. Turn crankshaft by about 90° in direction of engine rotation. Thereafter turn again in opposite direction of engine rotation until 8 mm before TDC (reversal point of dial gauge). Set graduated disc to „0“.	63. Virer le vilebrequin de 90° environ dans le sens opposé au sens de rotation du moteur. Ensuite virer à nouveau dans le sens de rotation du moteur jusqu'à 8 mm avant le PMH (point d'inversion du comparateur). Régler le disque gradué sur „0“.	63. Virare l'albero a gomiti di circa 90° contro il senso di rotazione del motore. Virarlo quindi nuovamente nel senso di rotazione del motore fino ad 8 mm prima del PMS (punto di inversione del movimento della lancetta del comparatore). Posizionare il disco graduato sullo "0".

**Deutsch**

**Werkstatthandbuch BFM 1012/E, BFM 1013/E**

60. Gradscheibe an Schwungradflansch anbauen.

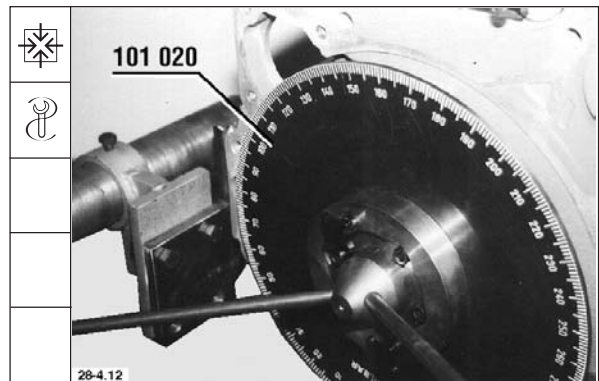

61. Zeiger anbauen.

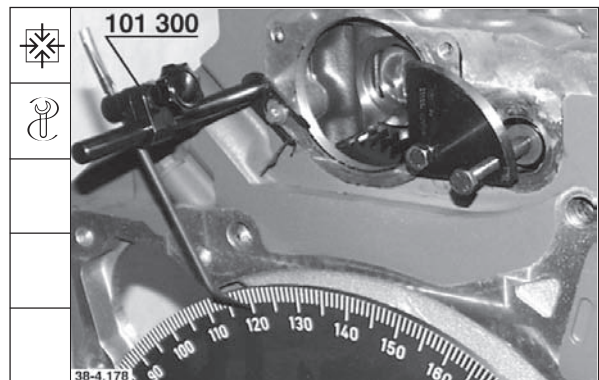

**Zünd O.T. des Kolbens ermitteln, der zur einzustellenden Einspritzpumpe gehört.**

62. O.T.-Meßbalken mit Abstandsplättchen auflegen. Kurbelwelle in Motordrehrichtung drehen bis der Zeiger der Meßuhr seinen Umkehrpunkt erreicht hat. Meßuhr auf "0" stellen.

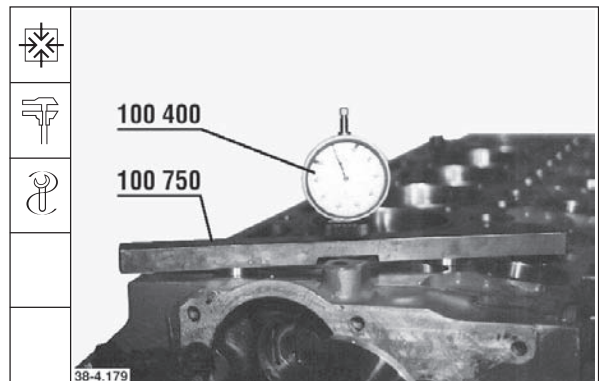

63. Kurbelwelle ca. 90° entgegen der Motordrehrichtung drehen. Danach wieder in Motordrehrichtung bis 8 mm vor O.T. (Umkehrpunkt der Meßuhr) drehen. Gradscheibe auf "0" stellen.

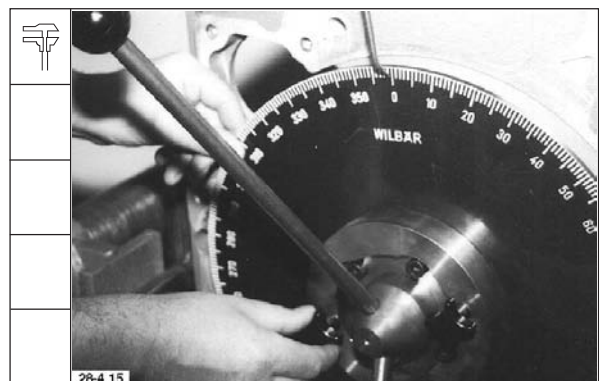



**Demontage und Montage, Motor komplett**  
**Disassembly and reassembly of complete engine**  
**Démontage et montage moteur complet**  
**Smontaggio e rimontaggio completo del motore**

**Werkstatthandbuch BFM 1012/E, BFM 1013/E**

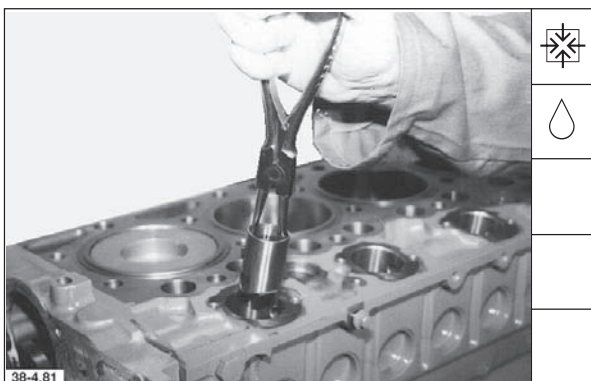
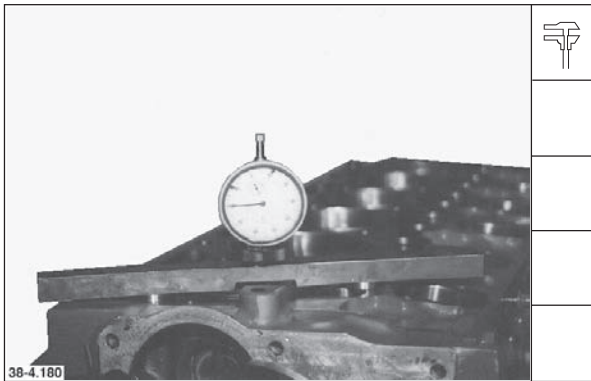

**Deutsch**

64. Kurbelwelle ca. 90° in Motordrehrichtung drehen. Danach wieder entgegen der Motordrehrichtung bis 8 mm vor O.T. (Umkehrpunkt der Meßuhr) drehen. Ermittelten Wert ablesen. Beispiel: 50°

65. Ermittelten Wert halbieren. Halbierter Wert ist O.T.

Beispiel:  $\frac{0^\circ + 50^\circ}{2} = 25^\circ$  IST

Kurbelwelle auf halbierten Wert drehen.

66. Kurbelwelle jetzt nicht mehr verdrehen. 2 Rändelschrauben lösen und Gradscheibe auf "0" stellen.

67. Rollenstößel einsetzen

**Demontage und Montage, Motor komplett**  
**Disassembly and reassembly of complete engine**  
**Démontage et montage moteur complet**  
**Smontaggio e rimontaggio completo del motore**

English	Français	Italiano
<p>64. Turn crankshaft by about 90° in direction of engine rotation. Thereafter turn again in opposite direction of engine rotation until 8 mm before TDC (reversal point of dial gauge). Read off determined value. Example: 50°</p>	<p>64. Virer le vilebrequin de 90° environ dans le sens opposé au sens de rotation du moteur. Ensuite virer à nouveau dans le sens de rotation du moteur jusqu'à 8 mm avant le PMH (point d'inversion du comparateur). Lire la valeur obtenue. Exemple : 50°</p>	<p>64. Virare l'albero a gomiti di circa 90° nel senso di rotazione del motore. Viirarlo quindi nuovamente contro il senso di rotazione del motore fino ad 8 mm prima del PMS (punto di inversione del movimento della lancetta del comparatore). Leggere il valore ottenuto. Per esempio: 50°</p>
<p>65. Halve the value determined. The halved value equals TDC.</p> <p>Example: <math>\frac{0^\circ + 50^\circ}{2} = 25^\circ</math> ACTUAL value</p> <p>Turn crankshaft until halved value is reached.</p>	<p>65. Diviser la valeur calculée par deux. La valeur divisée par deux est le PMH.</p> <p>Exemple: <math>\frac{0^\circ + 50^\circ}{2} = 25^\circ</math> REEL</p> <p>Virer le vilebrequin d'après cette valeur divisée par deux.</p>	<p>65. Dimezzare il valore ottenuto. Detto valore dimezzato è il PMS.</p> <p>Esempio: <math>\frac{0^\circ + 50^\circ}{2} = 25^\circ</math> valore effettivo</p> <p>Virare l'albero a gomiti, portandolo su tale valore.</p>
<p>66. Stop turning crankshaft. Loosen 2 knurled-head screws and set graduated disc to „0“.</p>	<p>66. Ne plus virer le vilebrequin. Desserrer les 2 vis moletées puis régler le disque gradué sur 0.</p>	<p>66. Non spostare più ora l'albero a gomiti. Allentare le due viti con la testa zigrinata e posizionare il disco graduato sullo "0".</p>
<p>67. Insert roller tappet.</p>	<p>67. Mettre en place le poussoir à galet.</p>	<p>67. Inserire le punterie a rullo.</p>

**Demontage und Montage, Motor komplett**  
**Disassembly and reassembly of complete engine**  
**Démontage et montage moteur complet**  
**Smontaggio e rimontaggio completo del motore**

English	Français	Italiano
<p><b>Determining commencement of delivery with Bosch injection pump</b></p>	<p><b>Calcul du début d'injection sur la pompe d'injection Bosch</b></p>	<p><b>Determinare l'inizio di mandata di una pompa d'iniezione Bosch</b></p>
<p>The commencement of delivery and since about 07.96 also the type of camshaft are stamped on the rating plate.</p>	<p>Le début d'injection et depuis juillet 1996 le type de l'arbre à cames sont indiqués sur la plaque signalétique.</p>	<p>L'inizio di mandata e circa da luglio 1996 anche il tipo di albero a camme sono stampigliati sulla targhetta di fabbrica.</p>
<p>68. Set dial gauge of measuring device under preload to 0. Set value: BFM 1012      <b>115 mm</b> (100 780)                     <b>126 mm</b> (100 860) BFM 1013      <b>150 mm</b> (100 840)</p>	<p>68. Régler le comparateur dans le dispositif de mesure à la valeur 0. Cote de réglage: BFM 1012      <b>115 mm</b> (100 780)                     <b>126 mm</b> (100 860) BFM 1013      <b>150 mm</b> (100 840)</p>	<p>68. Regolare sullo "0" il comparatore nel dispositivo di misura con precarico. Valore di regolazione: BFM 1012      <b>115 mm</b> (100 780)                     <b>126 mm</b> (100 860) BFM 1013      <b>150 mm</b> (100 840)</p>
<p>69. Position roller tappet of the injection pump to be timed on base circle. For that purpose turn crankshaft by about 180° opposite to direction of engine rotation.</p>	<p>69. Régler le poussoir à galet de la pompe d'injection à tarer sur le cercle de base. Pour cela virer le vilebrequin d'environ 180° dans le sens opposé au sens de rotation du moteur.</p>	<p>69. Appoggiare sul cerchio di base la punteria a rulli della pompa di iniezione da mettere a punto. A questo scopo virare l'albero a gomiti di circa 180° contro il senso di rotazione del motore.</p>
<p>70. Insert measuring device carefully.</p>	<p>70. Mettre en place le dispositif de mesure avec la plus grande précaution.</p>	<p>70. Introdurre con cautela il dispositivo di misura.</p>
<p>71. Measure dimension „L“, and enter in table 1, chapter 1.</p>	<p>71. Mesurer le cote „L“ puis inscrire cette valeur dans le tableau, voir chap. 1.</p>	<p>71. Misurare la lunghezza „L“ e riportarla nella tabella, vedi capitolo 1.</p>
<p>Example: BFM 1012      <b>116.26 mm</b>                     <b>126.57 mm</b> BFM 1013      <b>152.22 mm</b></p>	<p>Exemple: BFM 1012      <b>116,26 mm</b>                     <b>126,57 mm</b> BFM 1013      <b>152,22 mm</b></p>	<p>Esempio: BFM 1012      <b>116,26 mm</b>                     <b>126,57 mm</b> BFM 1013      <b>152,22 mm</b></p>



**Deutsch**

**Werkstatthandbuch BFM 1012/E, BFM 1013/E**

**Förderbeginn ermitteln Bosch-Einspritzpumpe**

Der Förderbeginn und seit ca. 07.96 auch der Nockenwellentyp, sind auf dem Firmenschild angegeben.

68. Meßuhr in Meßvorrichtung mit Vorspannung auf 0 stellen.

Einstellmaß:

BFM 1012     **115 mm** (100 780)

**126 mm** (100 860)

BFM 1013     **150 mm** (100 840)

69. Rollenstößel der zur einzustellenden Einspritzpumpe auf Grundkreis stellen. Hierzu Kurbelwelle ca. 180° entgegen der Motordrehrichtung drehen.

70. Meßvorrichtung vorsichtig einsetzen.

71. Maß "L" messen und in Tabelle, siehe Kapitel 1, eintragen.

Beispiel:

BFM 1012                             **116,26 mm**

**126,57 mm**

BFM 1013                             **152,22 mm**

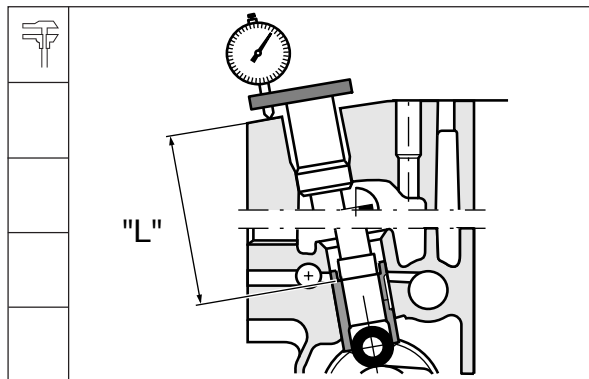
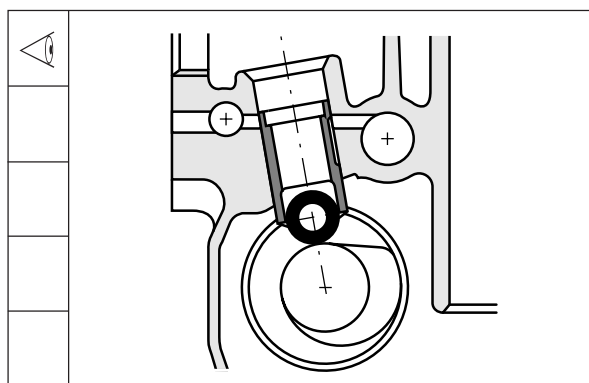
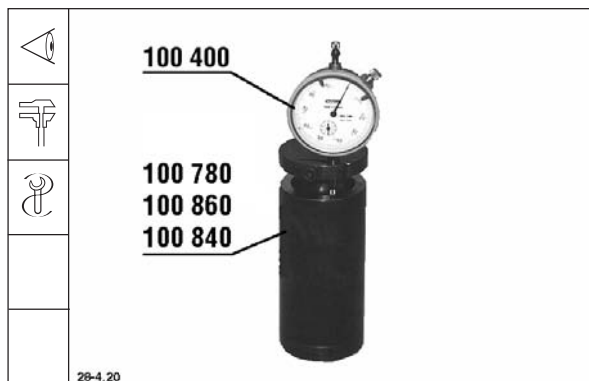

# Demontage und Montage, Motor komplett Disassembly and reassembly of complete engine Démontage et montage moteur complet Smontaggio e rimontaggio completo del motore

## Werkstatthandbuch BFM 1012/E, BFM 1013/E

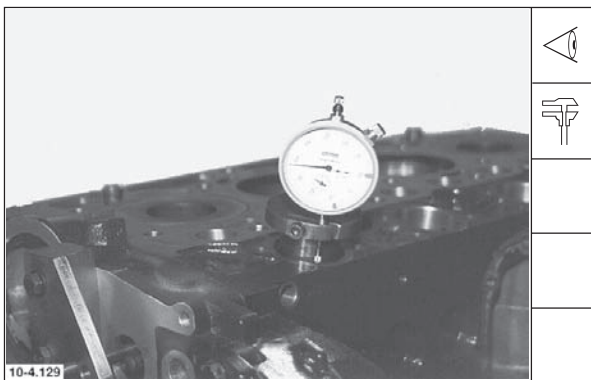
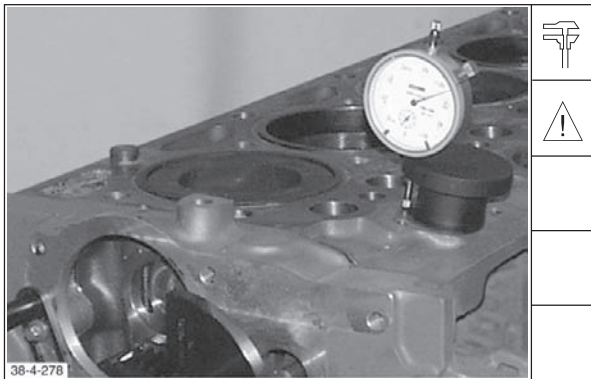

## Deutsch

72. Meßuhr über den Außenring auf Zeiger-Nullstellung drehen.

**Hinweis:** Bei der Vorhubeinstellung darf die Drehrichtung nicht mehr verändert werden.

73. Kurbelwelle in Motordrehrichtung drehen bis Meßuhr auf Vorhubmaß anzeigt. Siehe Tabelle 1.

Beispiel BFM 1012: Förderbeginn 9°  
Nockenwelle Typ C  
Vorhub **4,63 mm**

Beispiel BFM 1013: Förderbeginn 10°  
Nockenwelle Typ A  
Vorhub **5,31 mm**

74. Förderbeginn IST ablesen und in Tabelle, siehe Kapitel 1, eintragen.

Beispiel: BFM 1012 **8°**  
BFM 1013 **10°**

75. Maß "A" = Kennzahl für Einspritzpumpenlänge ablesen und in Tabelle, siehe Kapitel 1, eintragen.

Beispiel: BFM 1012 **53**  
BFM 1013 **133**

**Demontage und Montage, Motor komplett**  
**Disassembly and reassembly of complete engine**  
**Démontage et montage moteur complet**  
**Smontaggio e rimontaggio completo del motore**

English	Français	Italiano
<p>72. Set pointer of dial gauge to 0 with outer ring.</p> <p><b>Note:</b> The direction of rotation must not be changed anymore when the pre-stroke position has been reached.</p>	<p>72. Virer le comparateur au niveau de la bague extérieure en position 0.</p> <p><b>Nota:</b> pour le réglage de la précourse ne plus modifier le sens de rotation.</p>	<p>72. Per mezzo dell'anello esterno portare la lancetta del comparatore sulla posizione "0".</p> <p><b>Nota:</b> Durante la regolazione della precorsa non si può più cambiare il senso di rotazione.</p>
<p>73. Turn crankshaft in direction of engine rotation until dial gauge indicates pre-stroke dimension, see table 1.</p> <p>Example BFM 1012:            Comencement of delivery 9°            Camshaft type C            Pre-stroke <b>4,63 mm</b></p> <p>Example BFM 1013:            Comencement of delivery 10°            Camshaft type A            Pre-stroke <b>5,31 mm</b></p>	<p>73. Virer le vilebrequin dans le sens de rotation jusqu'à ce que le comparateur indique la cote de précourse. Voir tableau 1.</p> <p>Exemple BFM 1012:            début d'injection 9°            arbre à cames type C            précourse <b>4,63 mm</b></p> <p>Exemple BFM 1013:            début d'injection 10°            arbre à cames type A            précourse <b>5,31 mm</b></p>	<p>73. Virare l'albero a gomiti nel senso di rotazione del motore fino a quando il comparatore indica il valore della precorsa. Vedi Tabella 1.</p> <p>Esempio BFM 1012:            inizio di mandata 9°            albero a camme tipo C            precorsa <b>4,63 mm</b></p> <p>Esempio BFM 1013:            inizio di mandata 10°            albero a camme tipo A            precorsa <b>5,31 mm</b></p>
<p>74. Read off ACTUAL commencement of delivery and enter in table, chapter 1.</p> <p>Example:            BFM 1012 <b>8°</b>            BFM 1013 <b>10°</b></p>	<p>74. Lire début d'injection VALEUR REELLE et l'inscrire sur le tableau, voir chap. 1.</p> <p>Exemple:            BFM 1012 <b>8°</b>            BFM 1013 <b>10°</b></p>	<p>74. Leggere l'inizio di mandata effettivo e riportarlo nella tabella, vedi capitolo 1.</p> <p>Esempio:            BFM 1012 <b>8°</b>            BFM 1013 <b>10°</b></p>
<p>75. Read off dimension „A“ = code for injection pump length and enter in table, chapter 1.</p> <p>Example:            BFM 1012 <b>53</b>            BFM 1013 <b>133</b></p>	<p>75. Lire cote „A“ = indice de longueur de pompe d'injection et inscrire la valeur sur le tableau, voir chap. 1.</p> <p>Exemple:            BFM 1012 <b>53</b>            BFM 1013 <b>133</b></p>	<p>75. Misura "A" = leggere il numero caratteristico per la lunghezza della pompa d'iniezione e riportarlo nella tabella, vedi capitolo 1.</p> <p>Esempio:            BFM 1012 <b>53</b>            BFM 1013 <b>133</b></p>

**Demontage und Montage, Motor komplett**  
**Disassembly and reassembly of complete engine**  
**Démontage et montage moteur complet**  
**Smontaggio e rimontaggio completo del motore**

English	Français	Italiano
<p>76. Remove measuring device. Determine shims. See chapter 1.</p> <p>77. Position selected shim on roller tappet.</p> <p><b>Note:</b> The measuring procedures under items 62-77 is to be carried out for each injection pump.</p>	<p>76. Déposer l'appareil de mesure. Calculer l'épaisseur de la rondelle de compensation. Voir chap. 1.</p> <p>77. Placer la rondelle de compensation calculée sur le poussoir à galet.</p> <p><b>Nota:</b> effectuer le relevé des mesures indiquées aux points 62 à 77 pour chaque pompe d'injection.</p>	<p>76. Smontare il comparatore. Calcolare lo spessore delle rondelle. Vedi capitolo 1.</p> <p>77. Appoggiare la rondella sulla punteria a rullo.</p> <p><b>Nota:</b> La procedura di calcolo descritta dalla pos. 62 alla pos. 77 deve venire ripetuta per ogni pompa di iniezione.</p>
<p><b>Injection pump</b></p> <p>78. Turn injection pump linkage lever to approx. middle position.</p> <p><b>Note:</b> The assembly procedure under items 78-84 is to be carried out for each injection pump.</p> <p>79. Position roller tappet of relevant cylinder on base circle. Lightly oil receiving bore in crankcase and O-seals of injection pump. Carefully introduce injection pump linkage lever into control rod.</p>	<p><b>Pompe d'injection</b></p> <p>78. Virer le levier de la pompe d'injection approximativement en position milieu.</p> <p><b>Nota:</b> effectuer l'opération de montage du position 78 à 84 pour n'importe quelle pompe d'injection.</p> <p>79. Placer le poussoir à galet du cylindre concerné sur le cercle de base. Huiler légèrement les joints toriques de la pompe d'injection et l'alésage de positionnement du bloc moteur. Insérer avec précaution le levier de direction de la pompe d'injection sur la crémaillère.</p>	<p><b>Pompa d'iniezione</b></p> <p>78. Spostare il perno di regolazione della mandata della pompa d'iniezione circa sulla posizione mediana.</p> <p><b>Nota:</b> La procedura di montaggio descritta dalla pos. 78 alla pos. 84 deve venire ripetuta per ogni pompa di iniezione.</p> <p>79. Posizionare la punteria a rullo di ciascun cilindro sul cerchio di base. Oliare leggermente il foro di sede nella incastellatura, nonché gli O-ring della pompa d'iniezione. Introdurre con cautela nell'asta a cremagliera il perno di regolazione della mandata della pompa d'iniezione.</p>

**Deutsch**

**Werkstatthandbuch BFM 1012/E, BFM 1013/E**

76. Meßgerät abbauen.  
 Ausgleichsscheiben ermitteln.  
 Siehe Kapitel 1.



77. Ermittelte Ausgleichsscheibe auf  
 Rollenstößel auflegen.

**Hinweis:** Der Meßvorgang von Pos. 62 - 77 ist  
 für jede Einspritzpumpe durchzuführen.



**Einspritzpumpe**

78. Einspritzpumpenlenkhebel auf ca. Mittel-  
 stellung drehen .

**Hinweis:** Der Montagevorgang von Pos. 78 -  
 84 ist für jede Einspritzpumpe  
 durchzuführen.

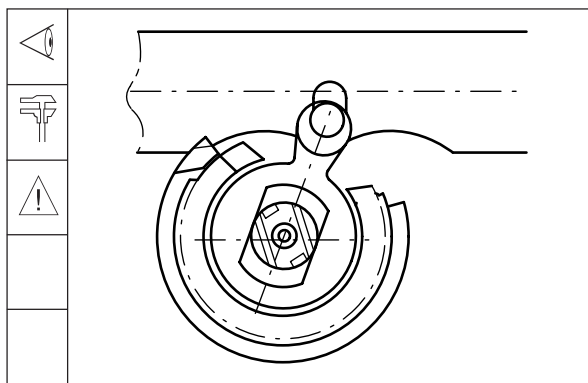

79. Rollenstößel des jeweiligen Zylinders auf  
 Grundkreis stellen.  
 Aufnahmebohrung im Kurbelgehäuse und  
 Runddichtringe der Einspritzpumpe leicht  
 einölen.  
 Einspritzpumpenlenkhebel vorsichtig in die  
 Regelstange einführen.

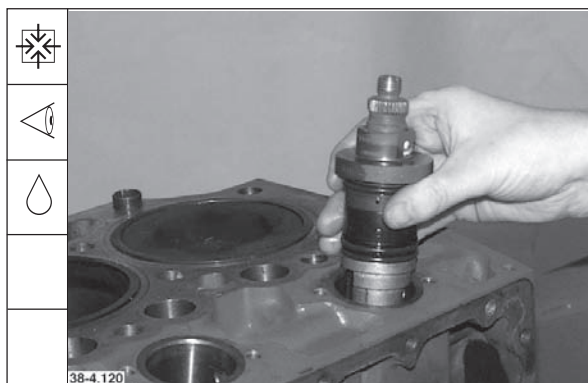

**Demontage und Montage, Motor komplett**  
**Disassembly and reassembly of complete engine**  
**Démontage et montage moteur complet**  
**Smontaggio e rimontaggio completo del motore**

Werkstatthandbuch BFM 1012/E, BFM 1013/E

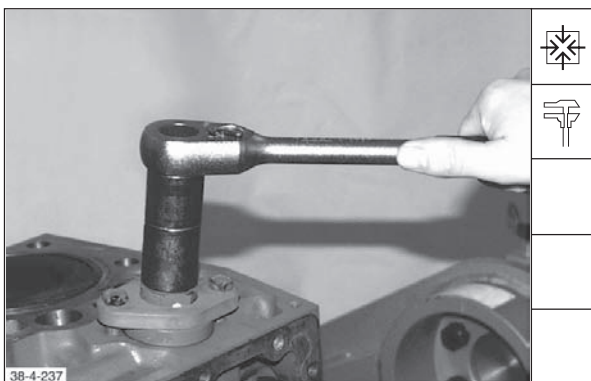
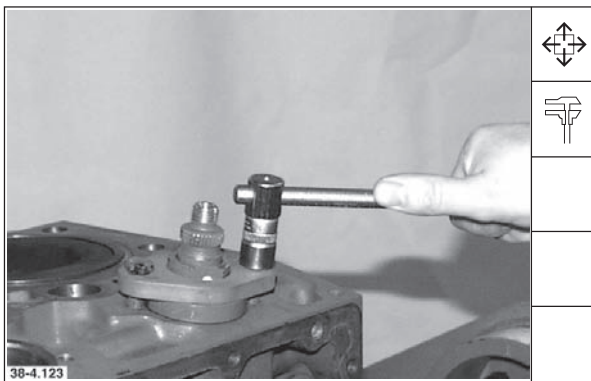
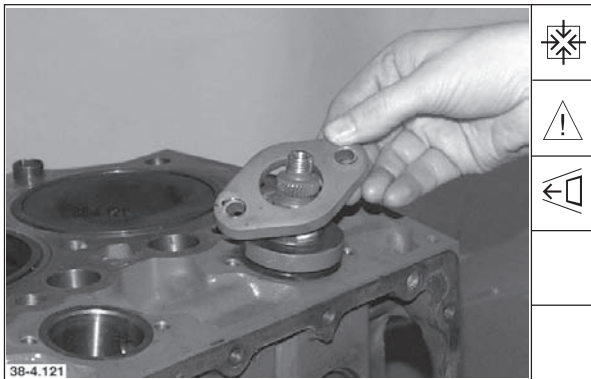

**Deutsch**

80. Flansch auflegen.

**Hinweis:** Anfasung muß zum Einspritzpumpenkörper weisen.

81. Schrauben leicht einölen und mit einem Drehmoment von **5 Nm** gleichmäßig festdrehen.

82. Schrauben wieder **60°** lösen.

83. Einspritzpumpe mit Verdrehschlüssel gegen Uhrzeigersinn vorsichtig bis zum fühlbaren Anschlag drehen.

**Demontage und Montage, Motor komplett**  
**Disassembly and reassembly of complete engine**  
**Démontage et montage moteur complet**  
**Smontaggio e rimontaggio completo del motore**

English	Français	Italiano
80. Position flange.  <b>Note:</b> Chamfer must face injection pump body.	<b>80.</b> Mettre en place la bride.  <b>Nota:</b> le chanfreinage doit être orienté vers le corps de la pompe d'injection.	<b>80.</b> Infilare la flangia sulla pompa d'iniezione.  <b>Nota:</b> Lo smusso deve essere rivolto verso il corpo della pompa d'iniezione.
81. Lightly oil bolts and tighten uniformly with a torque of <b>5 Nm</b> .	<b>81.</b> Huiler modérément les vis et les serrer uniformément au couple de <b>5 Nm</b> .	<b>81.</b> Oliare leggermente le viti e serrarle uniformemente con una coppia di <b>5 Nm</b> .
82. Loosen bolts again by <b>60°</b> .	<b>82.</b> Desserrer à nouveau les vis de <b>60°</b> .	<b>82.</b> Allentare nuovamente le viti di <b>60°</b> .
<b>83.</b> Turn injection pump with wrench carefully counter-clockwise until tangible stop.	<b>83.</b> Serrer avec précaution la pompe d'injection dans le sens antihoraire jusqu'en position de butée sensible.	<b>83.</b> Con l'ausilio di una chiave, girare con cautela la pompa d'iniezione in senso antiorario fino a percepirne la battuta.



**Demontage und Montage, Motor komplett**  
**Disassembly and reassembly of complete engine**  
**Démontage et montage moteur complet**  
**Smontaggio e rimontaggio completo del motore**

English	Français	Italiano
<p>84. Tighten bolts by 60° and then alternately with a torque of <b>7 Nm, 10 Nm and 30 Nm</b>.</p> <p><b>Note:</b> Start with the outer bolt, remote of the flywheel (see arrow).</p>	<p>84. Serrer à nouveau les vis à 60° et par passes successives au couple de <b>7 Nm, 10 Nm et 30 Nm</b>.</p> <p><b>Nota:</b> commencer à chaque fois par la vis extérieure la plus éloignée du volant moteur (voir flèche).</p>	<p>84. Serrare nuovamente le viti di 60° e stringerle quindi per gradi con una coppia di <b>7 Nm, 10 Nm e 30 Nm</b>.</p> <p><b>Nota:</b> Iniziare di volta con la vite esterna più lontana dal volano (vedi freccia).</p>
<p><b>Gauging control rod travel with injection pumps installed</b></p>	<p><b>Mesurer le déplacement de la crémaillère avec les pompes d'injection</b></p>	<p><b>Con le pompe d'iniezione installate, misurare la corsa dell'asta a cremagliera.</b></p>
<p>85. Undo setscrew from locking device. Turn locking device.</p>	<p>85. Dévisser et extraire la vis d'immobilisation du dispositif. Virer le dispositif.</p>	<p>85. Svitare e togliere la vite di arresto del dispositivo di bloccaggio dell'asta a cremagliera. Girare il dispositivo</p>
<p>86. Gauge from locking device to stop position of control rod.</p>	<p>86. Mesurer la distance entre le dispositif et la position stop de la crémaillère.</p>	<p>86. Misurare la distanza tra il dispositivo e la posizione di stop dell'asta a cremagliera.</p>
<p>86.1 Gauge from locking device to start position of control rod.</p>	<p>86.1 Mesurer la distance entre le dispositif et la position démarrage de la crémaillère.</p>	<p>86.1 Mesurare la distanza tra il suddetto dispositivo e la posizione di avviamento dell'asta a cremagliera.</p>
<p>Difference between stop and start positions equals control rod travel.</p>	<p>La différence par rapport à la position stop donne la course de la crémaillère.</p>	<p>Dalla differenza tra la posizione di stop e la posizione di avviamento si ottiene la corsa dell'asta a cremagliera.</p>
<p>Example:  stop position = 30.5 mm  start position = 13.4 mm  control rod travel = <b>17.1 mm</b></p>	<p>Exemple :  position stop = 30,5 mm  position démarrage = 13,4 mm  déplacement de la crémaillère = <b>17,1 mm</b>  Déplacement de la crémaillère <b>16,8 mm</b></p>	<p>Esempio:  posizione di stop = 30,5 mm  posizione di avviamento = 13,4 mm  Corsa dell'asta a crem. = <b>17,1 mm</b></p>
<p>Min. control rod travel <b>16.8 mm</b></p>	<p>Déplacement de la crémaillère <b>16,8 mm</b></p>	<p>Corsa dell'asta a cremagliera: <b>almeno 16,8 mm</b></p>



**Deutsch**

**Werkstatthandbuch BFM 1012/E, BFM 1013/E**

84. Schrauben wieder 60° festdrehen und in Stufen mit einem Drehmoment von **7 Nm**, **10 Nm** und **30 Nm** festdrehen.

**Hinweis:** Mit der jeweils außenliegenden, vom Schwungrad entfernteren Schraube beginnen. (siehe Pfeil)

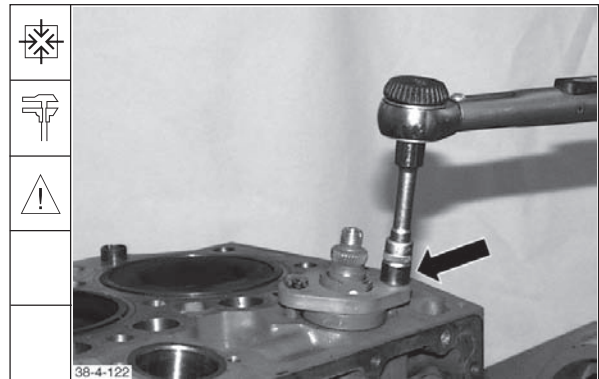

**Regelstangenweg messen mit Einspritzpumpen**

85. Feststellschraube aus Vorrichtung heraus-schrauben. Vorrichtung drehen.

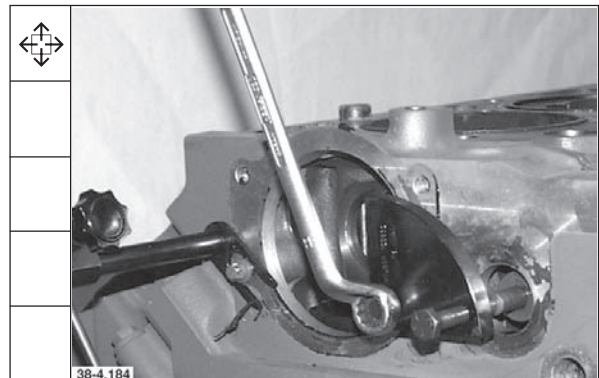

86. Von Vorrichtung bis zur Stopstellung der Regelstange messen.

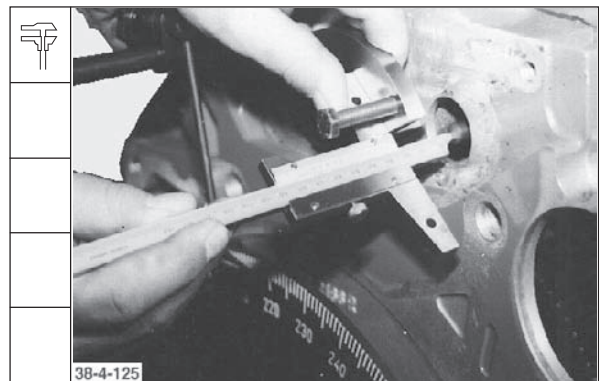

- 86.1 Von Vorrichtung bis zur Startstellung der Regelstange messen.

Differenz zur Stopstellung ergibt Regelstangenweg.

Beispiel: Stopstellung = 30,5 mm  
 Startstellung = 13,4 mm  
 Regelstangenweg = **17,1 mm**

Regelstangenweg mindestens **16,8 mm**

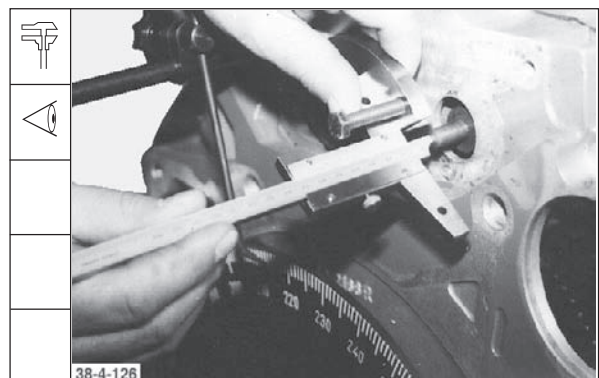

**Demontage und Montage, Motor komplett**  
**Disassembly and reassembly of complete engine**  
**Démontage et montage moteur complet**  
**Smontaggio e rimontaggio completo del motore**

**Werkstatthandbuch BFM 1012/E, BFM 1013/E**

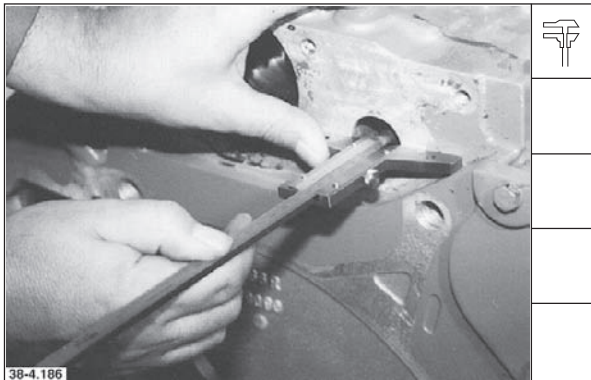
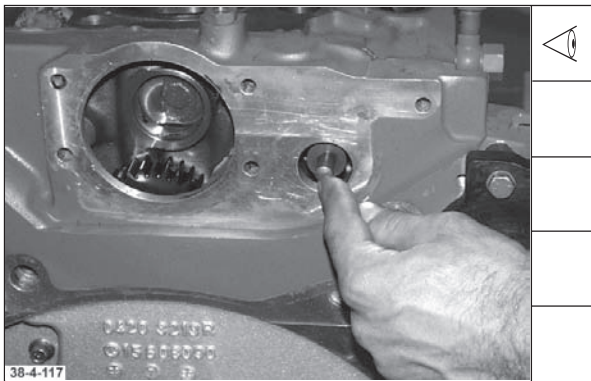
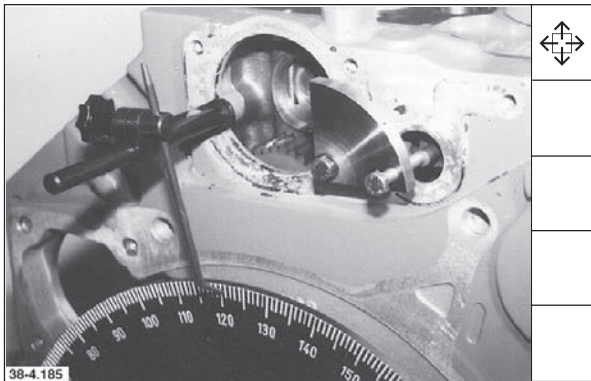

**Deutsch**

87. Feststellvorrichtung, Zeiger und Grad-  
scheibe abbauen.

**Leichtgängigkeit der Regelstange prüfen**

88. Beim langsamen Hineinschieben der  
Regelstange darf kein ungleichmäßiger  
Widerstand auftreten.  
Nach dem Loslassen muß die Regelstange  
durch die Feder aus jeder Position in die  
Ausgangslage zurückgedrückt werden.

**Regelstangenweg messen für Regleran-  
passung**

89. Regelstangenweg (Rückstandsmaß) vom  
Räderkastendeckel bis zur Stopstellung  
messen.

Dieses ermittelte Maß ist bei Regleraus-  
tausch oder Reglerreparatur unbedingt  
anzugeben.

**Demontage und Montage, Motor komplett**  
**Disassembly and reassembly of complete engine**  
**Démontage et montage moteur complet**  
**Smontaggio e rimontaggio completo del motore**

English	Français	Italiano
87. Remove locking device, pointer and graduated disc.	87. Déposer le dispositif d'immobilisation, l'index et le disque gradué.	87. Smontare il dispositivo di bloccaggio, l'indicatore ed il disco graduato.
<b>Checking ease of movement of control rod</b>	<b>Contrôle du libre coulissement de la crémaillère</b>	<b>Controllare che l'asta a cremagliera possa spostarsi liberamente</b>
88. When slowly introducing the control rod, there must not occur any unequal resistance. After detaching the control rod, the spring must press it from any position back into its original position	88. Lors de l'introduction lente de la crémaillère, aucune résistance irrégulière ne doit se produire. Après avoir relâché la crémaillère doit pouvoir revenir, grâce au ressort, dans sa position de départ à partir de n'importe quelle position.	88. Allorchè viene spinta dentro lentamente, l'asta a cremagliera non deve presentare una resistenza irregolare. Dopo averla lasciata libera, l'asta a cremagliera deve venire spinta indietro dalla molla nella sua posizione di partenza da qualsiasi posizione intermedia.
<b>Gauging control rod travel for governor adjustment</b>	<b>Mesurer la course de la crémaillère par ajustement du régulateur</b>	<b>Misurare la corsa dell'asta a cremagliera per l'aggiustaggio del regolatore.</b>
89. Gauge control rod travel from surface of timing chest cover to stop position. It is mandatory to indicate the dimension determined when replacing or repairing the governor.	89. Mesurer la course de la crémaillère (côte de retrait) du couvercle de la distribution à la position stop. Toujours indiquer cette cote lors d'un changement ou d'une réparation du régulateur.	89. Misurare la corsa dell'asta a cremagliera dal coperchio della scatola di distribuzione alla posizione di stop. Questa misura deve assolutamente venire fatta presente allorchè si deve sostituire o riparare il regolatore.

# Demontage und Montage, Motor komplett

## Disassembly and reassembly of complete engine

### Démontage et montage moteur complet

### Smontaggio e rimontaggio completo del motore

English	Français	Italiano
<p><b>Flywheel/V-belt pulley</b></p> <p>90. Position flywheel, using a selfmade guide mandrel. Secure bolts fingertight.</p> <p>91. Retain flywheel. Tighten bolts according to specification.</p> <p>Initial tightening torque Bolts 30 - 45 mm long _ <b>20-30 Nm</b> Bolts 50 - 85 mm long _ <b>30-40 Nm</b> 1st tightening angle bolts 30 - 85 mm long _____ <b>60°</b> 2nd tightening angle bolts 30 mm long _____ <b>30°</b> bolts 35-85 mm long _____ <b>60°</b></p> <p><b>Note:</b> Bolts may be used <b>5x</b> if evidence can be furnished concerning their use.</p> <p>92. Fit V-belt pulley and retain against flywheel. Tighten bolts according to specifications.</p> <p>Initial tightening torque _ <b>40-50 Nm</b> 1st tightening angle bolts 60 mm long _____ <b>60°</b> bolts 80 mm long _____ <b>60°</b></p> <p>2nd tightening angle bolts 60 mm long _____ <b>30°</b> bolts 80 mm long _____ <b>60°</b></p> <p><b>Note:</b> Use Torx socket wrench E20. Bolts may be used max. <b>5x</b> if evidence can be furnished concerning their use.</p>	<p><b>Volant moteur/poulie à gorge</b></p> <p>90. Mettre en place le volant moteur en utilisant un mandrin de guidage de fabrication locale. Serrer les vis à la main.</p> <p>91. Maintenir le volant moteur. Serrer les vis selon les consignes de serrage.</p> <p>Valeur de préserrage Vis 30 - 45 mm de long _ <b>20-30 Nm</b> Vis 50 - 85 mm de long _ <b>30-40 Nm</b> 1er serrage à l'angle vis 30 - 85 mm de long _____ <b>60°</b> 2e serrage à l'angle vis 30 mm de long _____ <b>30°</b> vis 35 - 85 mm de long _____ <b>60°</b></p> <p><b>Nota:</b> les vis peuvent être utilisées, selon la pratique, <b>5 fois</b> au maximum.</p> <p>92. Monter la poulie et maintenir le volant moteur. Serrer les vis selon les consignes de serrage.</p> <p>Valeur de préserrage _ <b>40 - 50 Nm</b> 1er serrage à l'angle vis 60 mm de long _____ <b>60°</b> vis 80 mm de long _____ <b>60°</b></p> <p>2e serrage à l'angle vis 60 mm de long _____ <b>30°</b> vis 80 mm de long _____ <b>60°</b></p> <p><b>Nota:</b> utiliser la clé à douille Torx E20. Les vis peuvent être utilisées, selon la pratique, <b>5 fois</b> au maximum.</p>	<p><b>Volano/Puleggia della cinghia trapezoidale</b></p> <p>90. Montare il volano utilizzando uno spinotto di guida autocostruita. Stringere le viti a mano.</p> <p>91. Tenendo bloccato il volano, serrare le viti in base alle prescrizioni.</p> <p>Preserraggio: viti lunghe 30 - 45 mm _ <b>20-30 Nm</b> viti lunghe 50 - 85 mm _ <b>30-40 Nm</b> I ripasso: viti lunghe 30 - 85 mm _____ <b>60°</b> Il ripasso: viti lunghe 30 mm _____ <b>30°</b> viti lunghe 35 - 85 mm _____ <b>60°</b></p> <p><b>Nota:</b> Se è documentabile, le viti possono venire utilizzate al massimo <b>5 volte</b>.</p> <p>92. Posizionare la puleggia della cinghia trapezoidale e tenerla contro il volano. Serrare le viti in base alle prescrizioni.</p> <p>Preserraggio: _____ <b>40-50 Nm</b> I ripasso: viti lunghe 60 mm _____ <b>60°</b> viti lunghe 80 mm _____ <b>60°</b></p> <p>Il ripasso: viti lunghe 60 mm _____ <b>30°</b> viti lunghe 80 mm _____ <b>60°</b></p> <p><b>Nota:</b> Fare uso della chiave a tubo E20 Torx. Se è documentabile, le viti possono venire utilizzate al massimo <b>5 volte</b>.</p>

**Deutsch**

**Werkstatthandbuch BFM 1012/E, BFM 1013/E**

**Schwungrad/Keilriemenscheibe**

90. Schwungrad unter Verwendung eines selbstgefertigten Führungsdornes aufsetzen. Schrauben handfest anziehen.

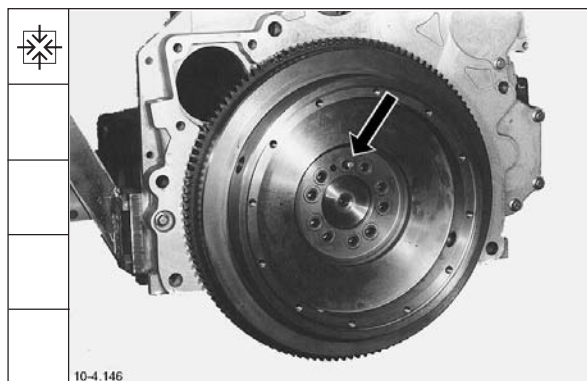

91. Schwungrad gegenhalten. Schrauben nach Anziehvorschrift festdrehen.

Vorspannwert:

Schrauben 30 - 45 mm lang \_\_ **20-30 Nm**

Schrauben 50 - 85 mm lang \_\_ **30-40 Nm**

1. Nachspannwinkel

Schrauben 30 - 85 mm lang \_\_\_\_\_ **60°**

2. Nachspannwinkel

Schrauben 30 mm lang \_\_\_\_\_ **30°**

Schrauben 35 - 85 mm lang \_\_\_\_\_ **60°**

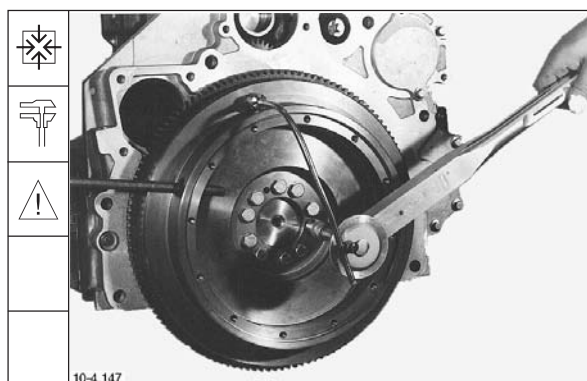

**Hinweis:** Schrauben können bei Nachweisbarkeit max. **5x** wiederverwendet werden.

92. Keilriemenscheibe anbauen und am Schwungrad gegenhalten. Schrauben nach Anziehvorschrift festdrehen.

Vorspannwert: \_\_\_\_\_ **40-50 Nm**

1. Nachspannwinkel

Schrauben 60 mm lang \_\_\_\_\_ **60°**

Schrauben 80 mm lang \_\_\_\_\_ **60°**

2. Nachspannwinkel

Schrauben 60 mm lang \_\_\_\_\_ **30°**

Schrauben 80 mm lang \_\_\_\_\_ **60°**

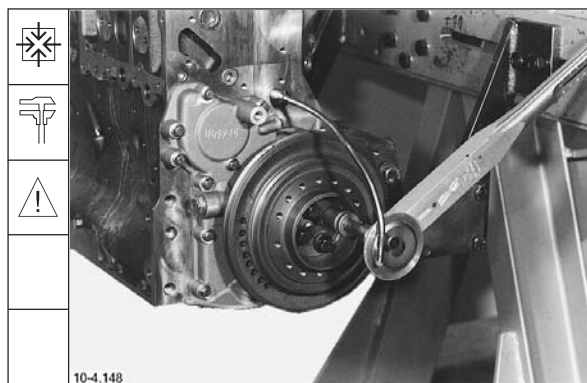

**Hinweis:** Torx-Steckschlüssel E20 verwenden. Schrauben können bei Nachweisbarkeit max. **5x** wiederverwendet werden.



**Demontage und Montage, Motor komplett**  
**Disassembly and reassembly of complete engine**  
**Démontage et montage moteur complet**  
**Smontaggio e rimontaggio completo del motore**

**Werkstatthandbuch BFM 1012/E, BFM 1013/E**

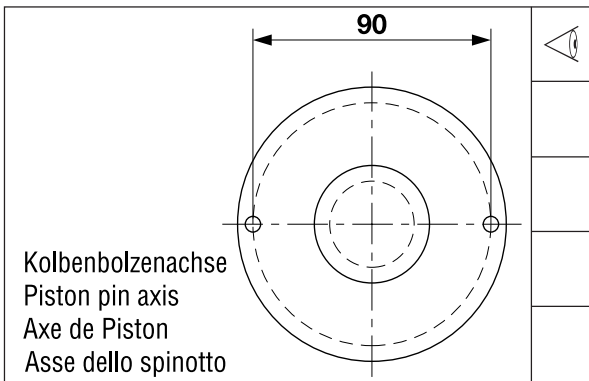
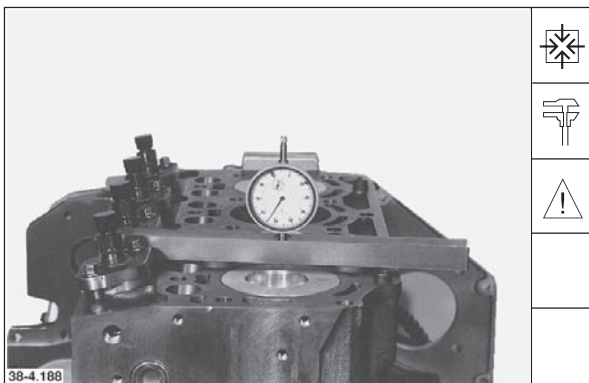
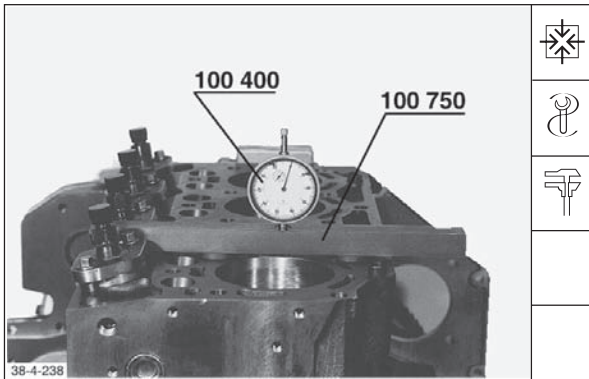

**Deutsch**

**Zylinderkopf**

- 93. Zylinderkopfdichtung bestimmen.
- 94. Abstandsplättchen auf die Dichtfläche des Zylinderkurbelgehäuse legen und Meßuhr auf "0" stellen.

- 95. Meßuhr an den Meßstellen auf den Kolben setzen und den größten Kolbenüberstand ermitteln.

**Hinweis:** Alle Kolben müssen vermessen werden.

- 96. Meßpunkte beachten.

BFM 1012	90 mm
BFM 1013	95 mm

**Demontage und Montage, Motor komplett**  
**Disassembly and reassembly of complete engine**  
**Démontage et montage moteur complet**  
**Smontaggio e rimontaggio completo del motore**

English	Français	Italiano
<b>Cylinder head</b>	<b>Culasse</b>	<b>Testa cilindri</b>
93. Determine cylinder head gasket.	93. Définir le joint de culasse.	93. Scelta della guarnizione di testa.
94. Place spacers on sealing surface of crankcase with integrated liners and set dial gauge to „0“.	94. Placer les plaquettes d'écartement sur le plan de joint du bloc moteur et régler le comparateur sur „0“.	94. Posizionare le piastrine distanziatrici sulla superficie di tenuta dell'incastellatura e registrare il comparatore sullo "0"
95. Position dial gauge on piston at gauge points and determine max. piston projection.	95. Placer le comparateur aux points de mesure sur le piston et calculer la plus grande cote d dépassement.	95. Posizionare il comparatore sui punti di misura sul pistone e calcolare la massima sporgenza del pistone.
<b>Note:</b> All pistons must be gauged.	<b>Nota:</b> le relevé des mesures doit être fait sur tous les pistons.	<b>Nota:</b> Tale misurazione va effettuata su tutti i pistoni.
96. Watch gauge points.	96. Veiller aux points de mesure.	96. Osservare i punti di misura.
BFM 1012      90 mm BFM 1013      95 mm	BFM 1012      90 mm BFM 1013      95 mm	BFM 1012                      90 mm BFM 1013                      95 mm

**Demontage und Montage, Motor komplett**  
**Disassembly and reassembly of complete engine**  
**Démontage et montage moteur complet**  
**Smontaggio e rimontaggio completo del motore**

English	Français	Italiano																								
97. Compare max. value with table and determine appropriate cylinder head gasket.	97. Comparer à l'aide du tableau la valeur la plus élevée puis définir le joint de culasse correspondant.	97. Confrontare il valore maggiore con la tabella e scegliere la guarnizione della testa cilindri corrispondente.																								
<b>BFM 1012</b>	<b>BFM 1012</b>	<b>BFM 1012</b>																								
<table border="1"> <thead> <tr> <th>Piston projection</th> <th>Marking of cylinder head gasket</th> </tr> </thead> <tbody> <tr> <td>0.43 - &lt; 0.64 mm</td> <td>1 hole</td> </tr> <tr> <td>0.64 - &lt; 0.74 mm</td> <td>2 holes</td> </tr> <tr> <td>0.74 - 0.85 mm</td> <td>3 holes</td> </tr> </tbody> </table>	Piston projection	Marking of cylinder head gasket	0.43 - < 0.64 mm	1 hole	0.64 - < 0.74 mm	2 holes	0.74 - 0.85 mm	3 holes	<table border="1"> <thead> <tr> <th>Cote de dépassement piston</th> <th>Caractéristique joint culasse</th> </tr> </thead> <tbody> <tr> <td>0,43 - &lt; 0,64 mm</td> <td>1 trou</td> </tr> <tr> <td>0,64 - &lt; 0,74 mm</td> <td>2 trous</td> </tr> <tr> <td>0,74 - 0,85 mm</td> <td>3 trous</td> </tr> </tbody> </table>	Cote de dépassement piston	Caractéristique joint culasse	0,43 - < 0,64 mm	1 trou	0,64 - < 0,74 mm	2 trous	0,74 - 0,85 mm	3 trous	<table border="1"> <thead> <tr> <th>Sporgenza del pistone</th> <th>Contrassegni sulla guarnizione</th> </tr> </thead> <tbody> <tr> <td>0,43 - &lt; 0,64 mm</td> <td>1 foro</td> </tr> <tr> <td>0,64 - &lt; 0,74 mm</td> <td>2 fori</td> </tr> <tr> <td>0,74 - 0,85 mm</td> <td>3 fori</td> </tr> </tbody> </table>	Sporgenza del pistone	Contrassegni sulla guarnizione	0,43 - < 0,64 mm	1 foro	0,64 - < 0,74 mm	2 fori	0,74 - 0,85 mm	3 fori
Piston projection	Marking of cylinder head gasket																									
0.43 - < 0.64 mm	1 hole																									
0.64 - < 0.74 mm	2 holes																									
0.74 - 0.85 mm	3 holes																									
Cote de dépassement piston	Caractéristique joint culasse																									
0,43 - < 0,64 mm	1 trou																									
0,64 - < 0,74 mm	2 trous																									
0,74 - 0,85 mm	3 trous																									
Sporgenza del pistone	Contrassegni sulla guarnizione																									
0,43 - < 0,64 mm	1 foro																									
0,64 - < 0,74 mm	2 fori																									
0,74 - 0,85 mm	3 fori																									
<b>BFM 1013</b>	<b>BFM 1013</b>	<b>BFM 1013</b>																								
<table border="1"> <thead> <tr> <th>Piston projection</th> <th>Marking of cylinder head gasket</th> </tr> </thead> <tbody> <tr> <td>0.28 - &lt; 0.54 mm</td> <td>1 hole</td> </tr> <tr> <td>0.54 - &lt; 0.64 mm</td> <td>2 holes</td> </tr> <tr> <td>0.64 - 0.75 mm</td> <td>3 holes</td> </tr> </tbody> </table>	Piston projection	Marking of cylinder head gasket	0.28 - < 0.54 mm	1 hole	0.54 - < 0.64 mm	2 holes	0.64 - 0.75 mm	3 holes	<table border="1"> <thead> <tr> <th>Cote de dépassement piston</th> <th>Caractéristique joint culasse</th> </tr> </thead> <tbody> <tr> <td>0,28 - &lt; 0,54 mm</td> <td>1 trou</td> </tr> <tr> <td>0,54 - &lt; 0,64 mm</td> <td>2 trous</td> </tr> <tr> <td>0,64 - 0,75 mm</td> <td>3 trous</td> </tr> </tbody> </table>	Cote de dépassement piston	Caractéristique joint culasse	0,28 - < 0,54 mm	1 trou	0,54 - < 0,64 mm	2 trous	0,64 - 0,75 mm	3 trous	<table border="1"> <thead> <tr> <th>Sporgenza del pistone</th> <th>Contrassegni sulla guarnizione</th> </tr> </thead> <tbody> <tr> <td>0,28 - &lt; 0,54 mm</td> <td>1 foro</td> </tr> <tr> <td>0,54 - &lt; 0,64 mm</td> <td>2 fori</td> </tr> <tr> <td>0,64 - 0,75 mm</td> <td>3 fori</td> </tr> </tbody> </table>	Sporgenza del pistone	Contrassegni sulla guarnizione	0,28 - < 0,54 mm	1 foro	0,54 - < 0,64 mm	2 fori	0,64 - 0,75 mm	3 fori
Piston projection	Marking of cylinder head gasket																									
0.28 - < 0.54 mm	1 hole																									
0.54 - < 0.64 mm	2 holes																									
0.64 - 0.75 mm	3 holes																									
Cote de dépassement piston	Caractéristique joint culasse																									
0,28 - < 0,54 mm	1 trou																									
0,54 - < 0,64 mm	2 trous																									
0,64 - 0,75 mm	3 trous																									
Sporgenza del pistone	Contrassegni sulla guarnizione																									
0,28 - < 0,54 mm	1 foro																									
0,54 - < 0,64 mm	2 fori																									
0,64 - 0,75 mm	3 fori																									
98. Position cylinder head gasket.	98. Placer le joint de culasse.	98. Appoggiare la guarnizione della testa cilindri.																								
<b>Note:</b> Sealing surfaces for cylinder head gasket must be clean and free of oil. Watch out for dowel sleeves.	<b>Nota:</b> les plans de joint du joint de culasse doivent être propres et sans huile. Veiller aux douilles d'ajustage.	<b>Nota:</b> La superficie di tenuta sulla quale si appoggia la guarnizione deve essere pulita ed esente da olio. Fare attenzione ai perni calibrati.																								



**Deutsch**

**Werkstatthandbuch BFM 1012/E, BFM 1013/E**

97. Größten Wert mit der Tabelle vergleichen und entsprechende Zylinderkopfdichtung ermitteln.

**BFM 1012**

Kolbenüberstand	Kennzeichnung der Zylinderkopfdichtung
0,43 - < 0,64 mm	1 Loch
0,64 - < 0,74 mm	2 Löcher
0,74 - 0,85 mm	3 Löcher

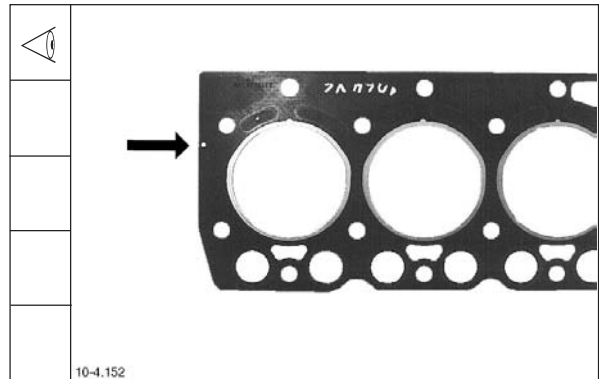

**BFM 1013**

Kolbenüberstand	Kennzeichnung der Zylinderkopfdichtung
0,28 - < 0,54 mm	1 Loch
0,54 - < 0,64 mm	2 Löcher
0,64 - 0,75 mm	3 Löcher

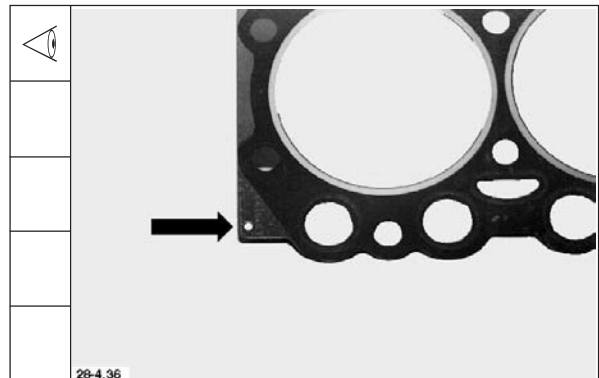

98. Zylinderkopfdichtung auflegen.

**Hinweis:** Dichtflächen für Zylinderkopfdichtung müssen sauber und ölfrei sein. Auf Paßhülsen achten.

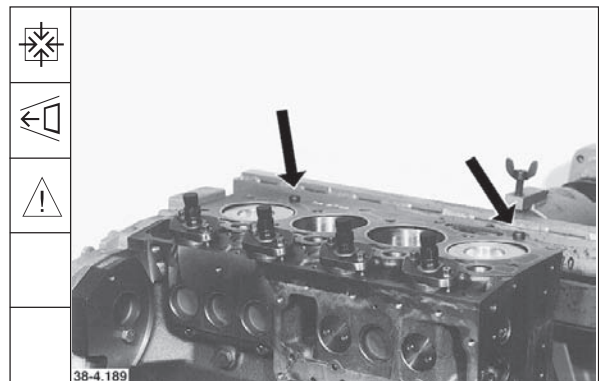

**Demontage und Montage, Motor komplett**  
**Disassembly and reassembly of complete engine**  
**Démontage et montage moteur complet**  
**Smontaggio e rimontaggio completo del motore**

Werkstatthandbuch BFM 1012/E, BFM 1013/E

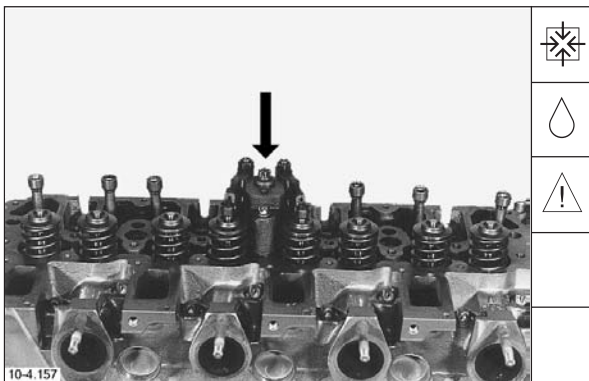
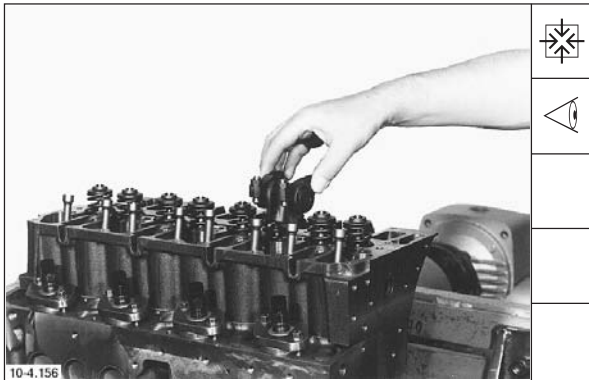
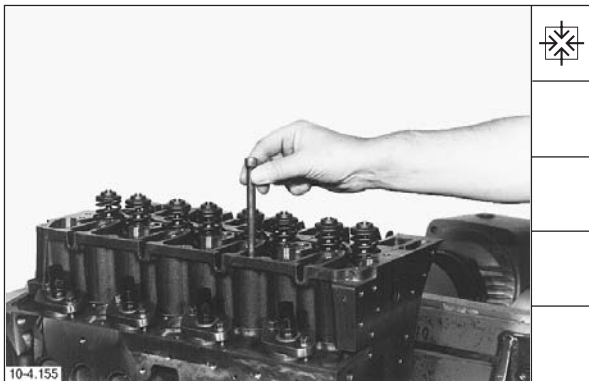
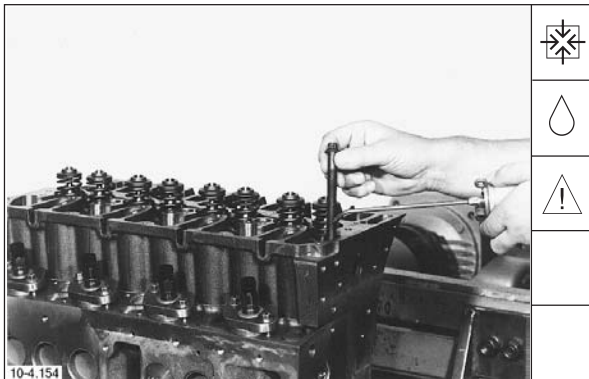

Deutsch

**Zylinderkopf mit Ventiltrieb BFM 1012**

99. Zylinderkopf aufsetzen. Kurze Zylinderkopfschrauben leicht einölen und beidrehen.

**Hinweis:** Zylinderkopfschrauben können bei Nachweisbarkeit max. **5x** verwendet werden.

100. Stoßstangen einsetzen.

101. Kipphebelbock montieren und zu den Stoßstangen/Ventilen ausrichten.

102. Lange Zylinderkopfschrauben leicht einölen und beidrehen. M8 Schraube einsetzen und beidrehen.

**Hinweis:** Zylinderkopfschrauben können bei Nachweisbarkeit max. **5x** verwendet werden.

**Demontage und Montage, Motor komplett**  
**Disassembly and reassembly of complete engine**  
**Démontage et montage moteur complet**  
**Smontaggio e rimontaggio completo del motore**

English	Français	Italiano
<p><b>Cylinder head with valve gear BFM 1012</b></p> <p>99. Position cylinder head. Lightly oil and start short cylinder head bolts.</p> <p><b>Note:</b> Cylinder head bolts may be reused max. <b>5x</b> if evidenced can be furnished concerning their use.</p> <p>100. Insert pushrods.</p> <p>101. Fit rocker arm bracket and align relative to pushrods/valves.</p> <p>102. Lightly oil and start long cylinder head bolts. Insert and start M8 bolt.</p> <p><b>Note:</b> Cylinder head bolts may be reused max. <b>5x</b> if evidenced can be furnished concerning their use.</p>	<p><b>Culasse et culbuterie du BFM 1012</b></p> <p>99. Mettre en place la culasse. Huiler légèrement les vis de culasse et les serrer modérément.</p> <p><b>Nota:</b> réutiliser les vis de culasse au moins <b>5 fois</b>.</p> <p>100. Mettre en place les tiges de culbuteurs.</p> <p>101. Monter le support des culbuteurs et l'aligner par rapport aux tiges de culbuteurs/soupapes.</p> <p>102. Huiler légèrement les vis de culasse longues et les serrer modérément. Placer une vis M8 et serrer à la main.</p> <p><b>Nota:</b> réutiliser les vis de culasse au moins <b>5 fois</b>.</p>	<p><b>Testa cilindri con meccanismo di azionamento delle valvole BFM 1012</b></p> <p>99. Montare la testa cilindri. Oliare leggermente le viti della testa ed avvitarle a mano.</p> <p><b>Nota:</b> Se è documentabile, le viti della testa possono venire riutilizzate al massimo <b>5 volte</b>.</p> <p>100. Introdurre le aste delle punterie.</p> <p>101. Montare il supporto dei bilancieri ed allinearlo con le aste dei bilancieri/Valvole.</p> <p>102. Oliare leggermente le viti della testa lunghe ed avvitarle a mano. Inserire la vite M8 ed avvitarla a mano.</p> <p><b>Nota:</b> Se è documentabile, le viti della testa possono venire riutilizzate al massimo <b>5 volte</b>.</p>

**Demontage und Montage, Motor komplett**  
**Disassembly and reassembly of complete engine**  
**Démontage et montage moteur complet**  
**Smontaggio e rimontaggio completo del motore**

English	Français	Italiano
<p>103. Tighten M8 bolt with a torque of <b>21 Nm</b>.</p>	<p>103. Serrer la vis M8 au couple de <b>21 Nm</b>.</p>	<p>103. Serrare la vite M8 con una coppia di <b>21 Nm</b>.</p>
<p>104. Tighten cylinder head bolts according to specification.</p> <p>Initial tightening torque:            1st stage _____ <b>30 Nm</b>            2nd stage _____ <b>80 Nm</b></p> <p>Tightening angle: _____ <b>90°</b></p>	<p>104. Serrer les vis de culasse selon les préconisations de serrage:</p> <p>Valeur préserrage            1ère phase _____ <b>30 Nm</b>            2ème phase _____ <b>80 Nm</b></p> <p>Serrage définitif: _____ <b>90°</b></p>	<p>104. Serrare leviti della testa cilindri in base alle prescrizioni.</p> <p>Preserraggio            I stadio _____ <b>30 Nm</b>            II stadio _____ <b>80 Nm</b></p> <p>Ripasso finale: _____ <b>90°</b></p>
<p><b>Note:</b> Observe tightening order for cylinder head bolts. See Specification Data.</p>	<p><b>Nota:</b> tenir compte de l'ordre de serrage des vis de culasse. Voir caractéristiques techniques.</p>	<p><b>Nota:</b> Rispettare la sequenza di serraggio delle viti della testa cilindri. Vedi i dati tecnici.</p>
<p><b>Note:</b> Adjust valve clearance - see chapter 2.</p>	<p><b>Nota:</b> pour le réglage du jeu aux soupapes voir chapitre 2.</p>	<p><b>Nota:</b> Registrazione del gioco delle valvole, vedi capitolo 2.</p>
<p><b>Cylinder head with valve gear BFM 1013</b></p>	<p><b>Culasse et culbuterie BFM 1013</b></p>	<p><b>Testa cilindri con meccanismo di azionamento delle valvole BFM 1013</b></p>
<p>105. Position cylinder head. Lightly oil and start cylinder head bolts.</p>	<p>105. Mettre la culasse en place. Huiler légèrement les vis de culasse et les serrer à la main.</p>	<p>105. Montare la testa cilindri. Oliare leggermente le viti della testa ed avvitare a mano.</p>
<p><b>Note:</b> Cylinder head bolts may be used max. <b>5x</b> if evidence can be furnished concerning their use.</p>	<p><b>Nota:</b> les vis de culasse sont réutilisables au moins <b>5 fois</b>.</p>	<p><b>Nota:</b> Se è documentabile, le viti della testa possono venire riutilizzate al massimo <b>5 volte</b>.</p>

**Deutsch**

**Werkstatthandbuch BFM 1012/E, BFM 1013/E**

103. M8 Schraube mit einem Drehmoment von **21 Nm** festdrehen.

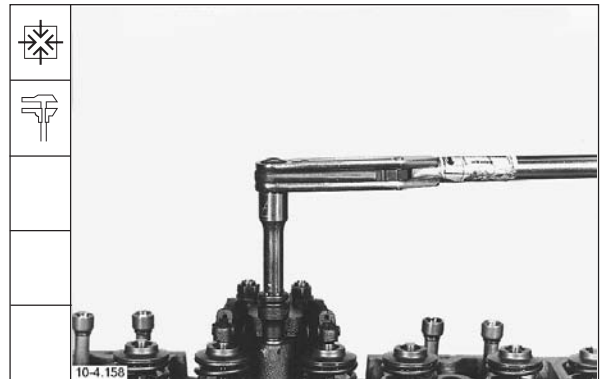

104. Zylinderkopfschrauben nach Anziehvorschrift festdrehen.

Vorspannwert:

1. Stufe \_\_\_\_\_ **30 Nm**

2. Stufe \_\_\_\_\_ **80 Nm**

Nachspannen: \_\_\_\_\_ **90°**

**Hinweis:** Reihenfolge beim Anziehen der Zylinderkopfschrauben beachten. Siehe Techn. Daten.

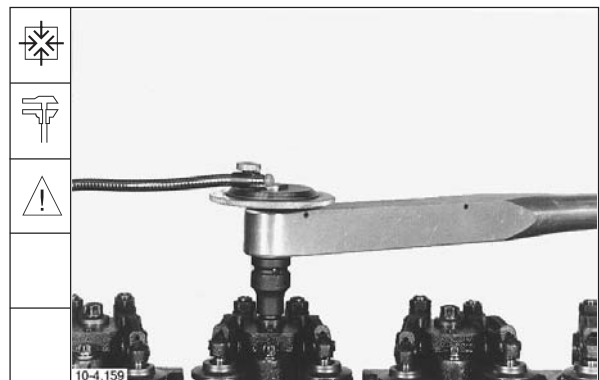

**Hinweis:** Ventilspiel einstellen siehe Kapitel 2.

**Zylinderkopf mit Ventiltrieb BFM 1013**

105. Zylinderkopf aufsetzen. Zylinderkopfschrauben leicht einölen und beidrehen.

**Hinweis:** Zylinderkopfschrauben können bei Nachweisbarkeit max. **5x** verwendet werden.

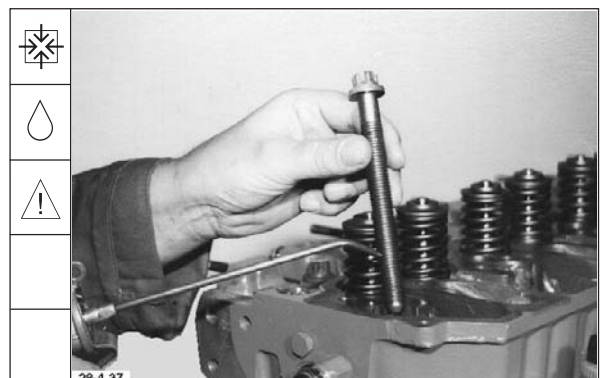

**Demontage und Montage, Motor komplett**  
**Disassembly and reassembly of complete engine**  
**Démontage et montage moteur complet**  
**Smontaggio e rimontaggio completo del motore**

Werkstatthandbuch BFM 1012/E, BFM 1013/E

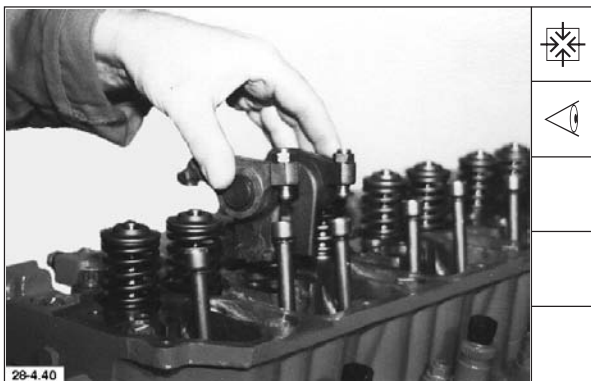
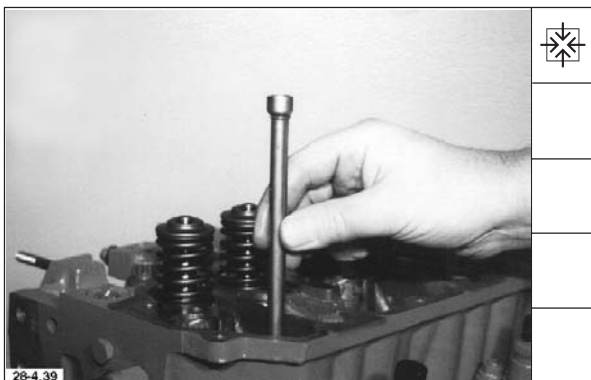

**Deutsch**

106. Zylinderkopfschrauben nach Anziehvorschrift festdrehen.

Vorspannwert:

1. Stufe \_\_\_\_\_ **50 Nm**

2. Stufe \_\_\_\_\_ **130 Nm**

Nachspannen: \_\_\_\_\_ **90°**

**Hinweis:** Reihenfolge beim Anziehen der Zylinderkopfschrauben beachten. Siehe Techn. Daten.

107. Stoßstangen einsetzen.

108. Kipphebelbock montieren und zu den Stoßstangen/Ventilen ausrichten.

109. Schraube mit einem Drehmoment von **21 Nm** festdrehen.

**Hinweis:** Ventilspiel einstellen, siehe Kapitel 2.

**Demontage und Montage, Motor komplett**  
**Disassembly and reassembly of complete engine**  
**Démontage et montage moteur complet**  
**Smontaggio e rimontaggio completo del motore**

English	Français	Italiano
<p>106. Tighten cylinder head bolts according to specification.</p> <p>Initial tightening torque:            1st stage _____ <b>50 Nm</b>            2nd stage _____ <b>130 Nm</b>            Tightening angle: _____ <b>90°</b></p> <p><b>Note:</b> Observe tightening order for cylinder head bolts. See Specification Data.</p>	<p>106. Serrer les vis de culasse selon les préconisations de serrage.</p> <p>Valeur préserrage:            1ère phase _____ <b>50 Nm</b>            2ème phase _____ <b>130 Nm</b>            Serrage définitif _____ <b>90°</b></p> <p><b>Nota:</b> tenir compte de l'ordre de serrage des vis de culasse. Voir caractéristiques techniques.</p>	<p>106. Serrare le viti della testa cilindri in base alle prescrizioni.</p> <p>Preserraggio            I stadio _____ <b>50 Nm</b>            II stadio _____ <b>130 Nm</b>            Ripasso finale: _____ <b>90°</b></p> <p><b>Nota:</b> Rispettare la sequenza di serraggio delle viti della testa cilindri. Vedi i dati tecnici.</p>
<p>107. Insert pushrods.</p>	<p>107. Introduire les tiges de culbuteurs.</p>	<p>107. Introdurre le aste delle punterie.</p>
<p>108. Fit rocker arm bracket and align towards pushrods/valves.</p>	<p>108. Monter le support des culbuteurs et l'aligner par rapport aux tiges de culbuteurs/soupapes.</p>	<p>108. Montare il supporto dei bilancieri ed allinearlo con le aste dei bilancieri/Valvole.</p>
<p>109. Tighten bolt with a torque of <b>21 Nm</b>.</p> <p><b>Note:</b> Adjust valve clearance, see chapter 2.</p>	<p>109. Serrer la vis M8 au couple de <b>21 Nm</b>.</p> <p><b>Nota:</b> pour le réglage du jeu aux soupapes voir chapitre 2.</p>	<p>109. Serrare la vite con una coppia di <b>21 Nm</b>.</p> <p><b>Nota:</b> Regolazione del gioco delle valvole, vedi capitolo 2.</p>

**Demontage und Montage, Motor komplett**  
**Disassembly and reassembly of complete engine**  
**Démontage et montage moteur complet**  
**Smontaggio e rimontaggio completo del motore**

English	Français	Italiano
<p>110. Fit pencil-type glow plugs or blanking parts.</p> <p>111. Tighten pencil-type glow plugs or blanking parts with a torque of <b>20 ± 2 Nm</b>.</p>	<p>110. Monter les bougies de préchauffage ou les éléments de fermeture.</p> <p>111. Serrer les bougies de préchauffage ou les éléments de fermeture au couple de <b>20 ± 2 Nm</b>.</p>	<p>110. Montare le candeelette di preriscaldamento oppure i particolari di chiusura in loro mancanza.</p> <p>111. Serrare le candeelette di preriscaldamento od i particolari di chiusura con una coppia di <b>20 ± 2 Nm</b>.</p>
<p><b>Shutdown solenoid</b></p>	<p><b>Electroaimant d'arrêt</b></p>	<p><b>Elettromagnete d'arresto</b></p>
<p>112. Press control rod into <b>stop position</b> and hold in place. Fit shutdown solenoid with new O-seal.</p>	<p>112. Pousser et maintenir la crémaillère en <b>position de stop</b>. Monter électroaimant d'arrêt avec un joint torique neuf.</p>	<p>112. Spingere l'asta a cremagliera nella <b>posizione di stop</b> e trattenervela. Montare l'elettromagnete di arresto dopo averlo munito di un nuovo O-ring.</p>
<p><b>Note:</b> Lightly oil O-seal.</p>	<p><b>Nota:</b> huiler légèrement le joint torique.</p>	<p><b>Nota:</b> Oliare leggermente l'O-ring.</p>
<p>113. Tighten bolts with a torque of <b>21 Nm</b>.</p>	<p>113. Serrer les vis au couple de <b>21 Nm</b>.</p>	<p>113. Serrare le viti con una coppia di <b>21 Nm</b>.</p>



Deutsch

Werkstatthandbuch BFM 1012/E, BFM 1013/E

110. Glühstiftkerzen oder Verschlußteile einbauen.

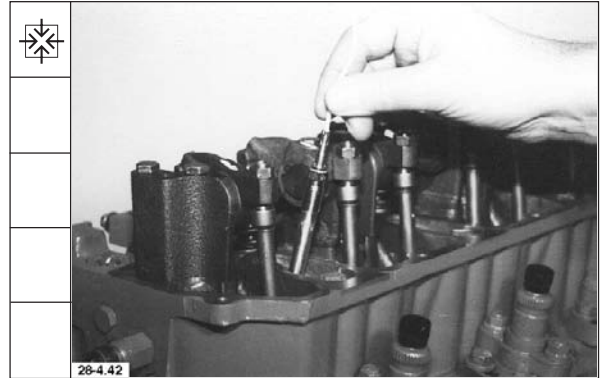

111. Glühstiftkerzen oder Verschlußteile mit einem Drehmoment von  $20 \pm 2$  Nm festdrehen.



**Abstellmagnet**

112. Regelstange in **Stop-Stellung** drücken und festhalten. Abstellmagnet mit neuem Runddichtring einbauen.

**Hinweis:** Runddichtring leicht einölen.

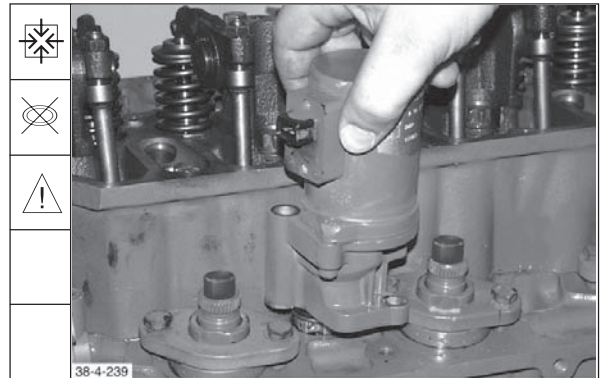

113. Schrauben mit einem Drehmoment von  $21$  Nm festdrehen.

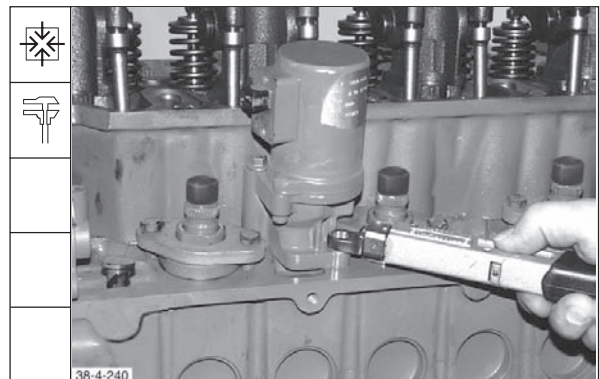

# Demontage und Montage, Motor komplett Disassembly and reassembly of complete engine Démontage et montage moteur complet Smontaggio e rimontaggio completo del motore

Werkstatthandbuch BFM 1012/E, BFM 1013/E

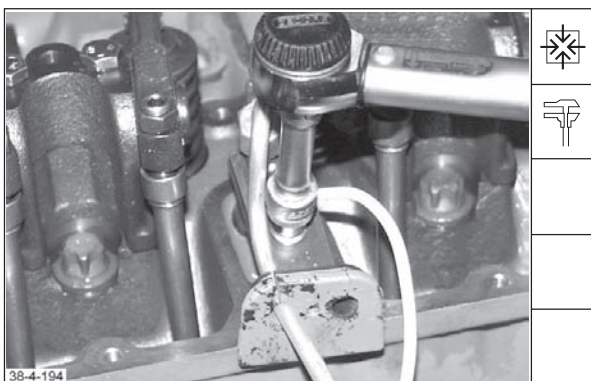
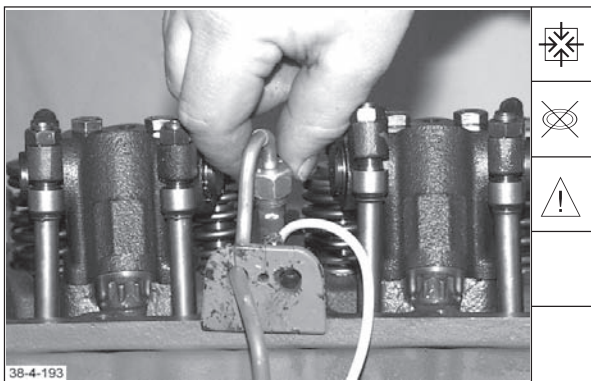
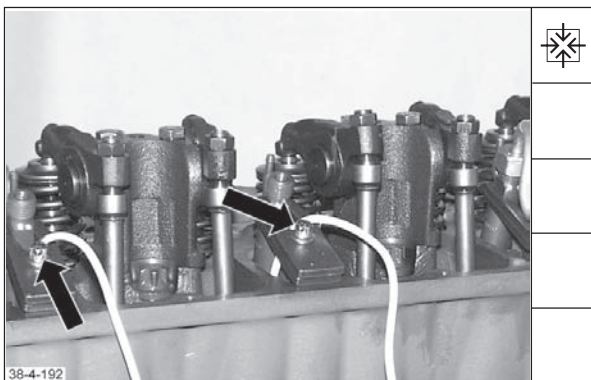
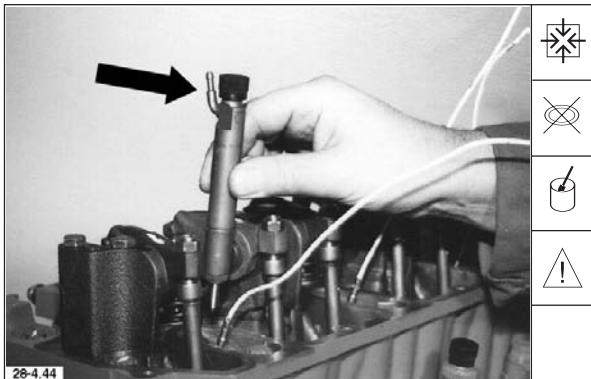

## Deutsch

### Einspritzventil/Einspritzleitungen

114. Neue Dichtung mit etwas Fett auf das Einspritzventil aufschieben und Einspritzventil einsetzen.

**Hinweis:** Leckölanschluß muß zur Abgasseite weisen.

115. Spannpratzen aufsetzen. Schraube lose einschrauben.

116. Neue Einspritzleitung mit Dichtgummi anbauen. Überwurfmuttern fingerfest aufschrauben.

**Hinweis:** Bei Montage der Einspritzleitungen müssen die Dichtkone exakt aufeinander sitzen.

**Ein Nachbiegen ist nicht zulässig. Die Einspritzleitungen dürfen nicht 2x verwendet werden.**

117. Schraube der Spannpratzen mit einem Drehmoment von **16 + 5 Nm** festdrehen.

**Demontage und Montage, Motor komplett**  
**Disassembly and reassembly of complete engine**  
**Démontage et montage moteur complet**  
**Smontaggio e rimontaggio completo del motore**

English	Français	Italiano
<p><b>Injector/injection lines</b></p> <p>114. Slide new seal over injector using some grease and insert injector.</p> <p><b>Note:</b> leakage fuel line connection must face the exhaust side.</p> <p>115. Position clamping pads. Start bolt.</p> <p>116. Fit new injection line with sealing rubber. Screw on cap nuts finger-tight.</p> <p><b>Note:</b> When fitting the injection lines, the sealing cones must match precisely.  <b>Rebending is not permissible. The injection lines must not be used twice.</b></p> <p>117. Tighten bolt of clamping pads with a torque of <b>16 + 5 Nm</b>.</p>	<p><b>Injecteur/conduites d'injection</b></p> <p>114. Insérer avec un peu de graisse un joint neuf sur l'injecteur et mettre en place l'injecteur.</p> <p><b>Nota:</b> le raccordement de la conduite de retour des fuites doit être orienté dans le sens échappement.</p> <p>115. Placer les griffes de serrage et visser boulon sans serrer.</p> <p>116. Monter une conduite d'injection neuve avec un caoutchouc d'étanchéité. Serrer les écrous-raccords modérément à la main.</p> <p><b>Nota:</b> au montage des conduites d'injection les cônes d'étanchéité doivent parfaitement correspondre.  <b>Un recintrade n'est pas autorisé. Ne jamais utiliser deux fois les conduites d'injection.</b></p> <p>117. Visser le boulon des griffes de serrage au couple de <b>16 + 5 Nm</b>.</p>	<p><b>Inietture/Tubazioni d'iniezione</b></p> <p>114. Dopo averla ingrassata leggermente, infilare una nuova guarnizione sull'inietttore. Montare quindi l'inietttore.</p> <p><b>Nota:</b> Il raccordo per la tubazione di ricupero del combustibile deve essere rivolto verso il lato scarico.</p> <p>115. Montare le staffe di serraggio. Avvitare a mano la vite.</p> <p>116. Montare una nuova tubazione d'iniezione con i suoi gommini di tenuta. Avvitare a mano il dado di raccordo.</p> <p><b>Nota:</b> Allorchè vengono montate le tubazioni di iniezione si deve far in modo che i coni di tenuta corrispondano esattamente agli attacchi.  <b>Non è ammesso piegare le tubazioni per adattarle. Le tubazioni di iniezione non possono venire impiegate 2 volte.</b></p> <p>117. Serrare la vite delle staffe di serraggio con una coppia di <b>16 + 5 Nm</b>.</p>

**Demontage und Montage, Motor komplett**  
**Disassembly and reassembly of complete engine**  
**Démontage et montage moteur complet**  
**Smontaggio e rimontaggio completo del motore**

English	Français	Italiano
<p>118. Preload cap nuts of injection line on injection pump and injector with a torque of <b>approx. 5 Nm</b>. Thereafter tighten cap nuts with a torque of <b>25 + 3.5 Nm</b>.</p>	<p>118. Préserrer les écrous-raccords de la conduite d'injection de la pompe d'injection et de l'injecteur au couple d'environ <b>5 Nm</b>. Ensuite bloquer les écrous-raccords au couple de <b>25 + 3,5 Nm</b>.</p>	<p>118. Il preserraggio dei dadi di raccordo delle tubazioni di iniezione con le pompe di iniezione e con gli iniettori deve venire eseguito con una coppia di circa <b>5 Nm</b>. Serrare quindi i dadi di raccordo con una coppia di <b>25 + 3,5 Nm</b>.</p>
<p>119. Fit leakage fuel line and introduce through sealing rubber.</p>	<p>119. Monter la conduite de retour des fuites et la faire passer à travers les caouchoucs d'étanchéité.</p>	<p>119. Montare le tubazioni di ricupero del combustibile introducendole attraverso le tenute di gomma.</p>
<p><b>Note:</b> Leagee fuel lines must always be replaced.</p>	<p><b>Nota:</b> Il faut en principe renouveler les conduites de retour d'huile de fuite.</p>	<p><b>Nota:</b> Le tubazioni di ricupero del combustibile vanno di norma sostituite.</p>
<p>120. Fit overflow valve with new Cu seals and leakage fuel line. Tighten overflow valve with a torque of <b>30 Nm</b>.</p>	<p>120. Monter la soupape de décharge avec des joints Cu neufs et la conduite de retour des fuites. Serrer la soupape de décharge au couple de <b>30 Nm</b>.</p>	<p>120. Montare la valvola limitatrice di mandata con nuove guarnizioni di rame, nonché le tubazioni di ricupero del combustibile. Serrare la valvola limitatrice di mandata con una coppia di <b>30 Nm</b>.</p>
<p><b>Air intake/exhaust manifold</b></p>	<p><b>Collecteur d'admission/collecteur d'échappement</b></p>	<p><b>Tubazione dell'aria di sovralimentazione/Collettore di scarico</b></p>
<p>121. Mount air intake manifold with new gaskets.</p>	<p>121. Monter le collecteur d'admission avec des joints neufs.</p>	<p>121. Montare la tubazione dell'aria di sovralimentazione munita di nuove guarnizioni.</p>

**Deutsch**

**Werkstatthandbuch BFM 1012/E, BFM 1013/E**

118. Überwurfmutter der Einspritzleitung an Einspritzpumpe und Einspritzventil mit einem Drehmoment von **ca. 5 Nm** vorspannen. Danach die Überwurfmutter mit einem Drehmoment von **25 + 3,5 Nm** festdrehen.

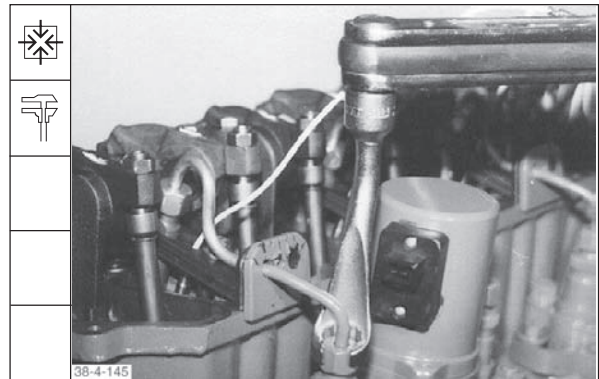

119. Leckölleitung anbauen und durch Dichtungsmis einführen.

**Hinweis:** Leckölleitungen sind grundsätzlich zu erneuern.

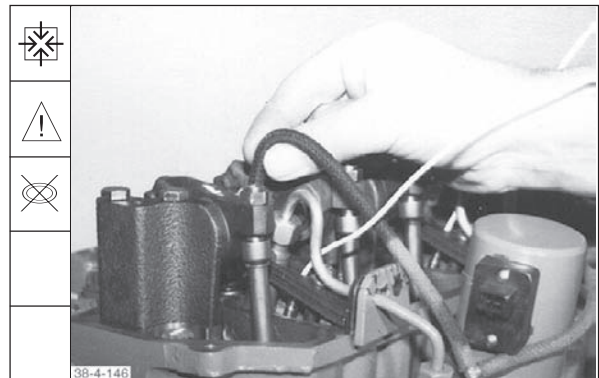

120. Überströmventil mit neuen Cu-Dichtungen und Leckölleitung anbauen. Überströmventil mit einem Drehmoment von **30 Nm** festdrehen.

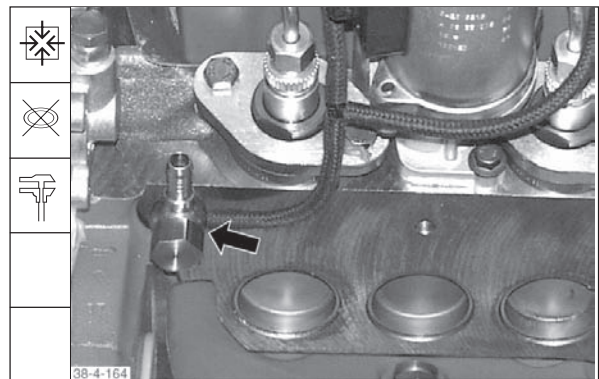

**Luftansaugrohr/Abgassammelrohr**

121. Luftansaugrohr mit neuen Dichtungen anbauen.





**Demontage und Montage, Motor komplett**  
**Disassembly and reassembly of complete engine**  
**Démontage et montage moteur complet**  
**Smontaggio e rimontaggio completo del motore**

Werkstatthandbuch BFM 1012/E, BFM 1013/E

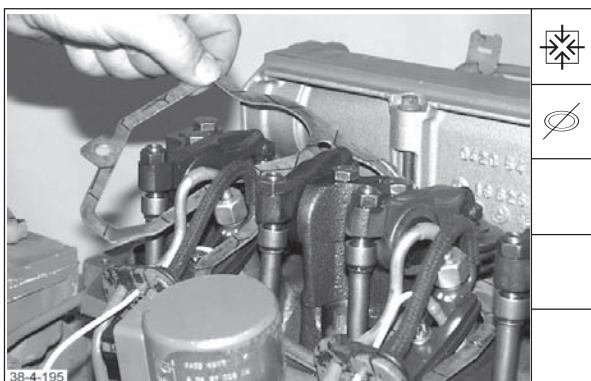
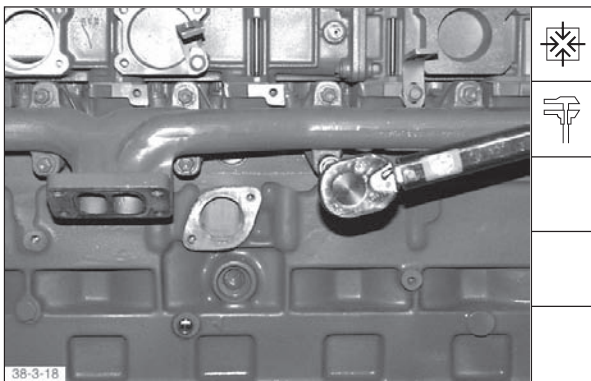
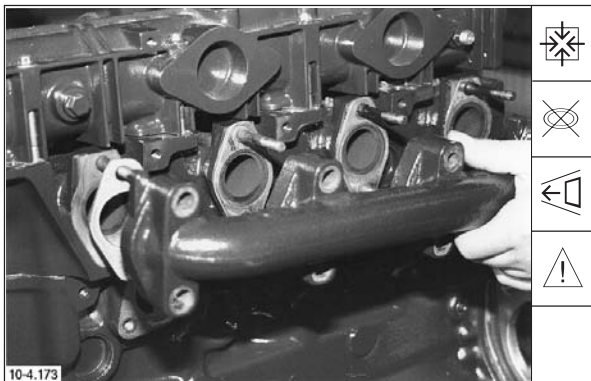
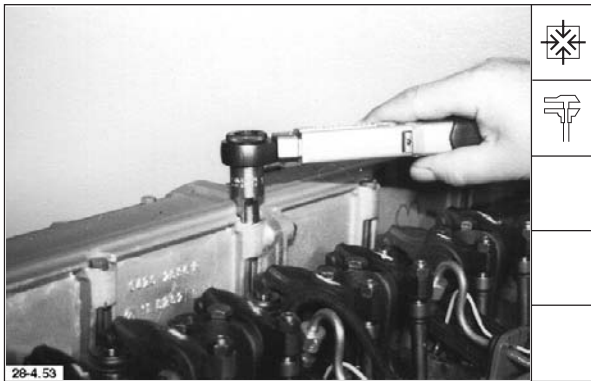

**Deutsch**

122. Schrauben für Ladeluftleitung mit einem Drehmoment von **11 ± 1 Nm** festdrehen.

123. Abgassammelrohr mit neuen Dichtungen anbauen.  
 Die Umbördelung der Dichtung muß zum Zylinderkopf weisen.

**Hinweis:** Stiftschrauben mit **Deutz S1**  
 Never Seize-Paste einstreichen.

124. Muttern für Abgassammelrohr mit einem Drehmoment von **25 ± 2,5 Nm** festdrehen.

**Zylinderkopfhaube**

125. Dichtung aufsetzen.

**Demontage und Montage, Motor komplett**  
**Disassembly and reassembly of complete engine**  
**Démontage et montage moteur complet**  
**Smontaggio e rimontaggio completo del motore**

English	Français	Italiano
122. Tighten bolts for charge air pipe with a torque of <b>11 ± 1 Nm</b> .	122. Serrer les vis de la conduite d'air de suralimentation au couple de <b>11 ± 1 Nm</b> .	122. Serrare le viti della tubazione dell'aria di sovralimentazione con una coppia di <b>11 ± 1 Nm</b> .
123. Mount exhaust manifold with new gaskets. The gasket bead must point towards the cylinder head.	123. Monter le collecteur d'échappement avec des joints neufs. Le bord rabattu du joint doit être orienté vers la culasse.	123. Montare il collettore di scarico con nuove guarnizioni. La bordatura delle guarnizioni deve essere rivolta verso la testa cilindri.
<b>Note:</b> Apply <b>Deutz S1</b> Never Seize paste to studs.	<b>Nota:</b> enduire les goujons filetés de pâte <b>Deutz S1</b> Never Seize.	<b>Nota:</b> I prigionieri devono venire spalmati con la pasta <b>Deutz S1</b> Never Seize.
124. Tighten nuts for exhaust manifold with a torque of <b>25 ± 2,5 Nm</b> .	124. Serrer les écrous du collecteur d'échappement au couple de <b>25 ± 2,5 Nm</b> .	124. Serrare i dadi del collettore di scarico con una coppia di <b>25 ± 2,5 Nm</b> .
<b>Cylinder head cover</b>	<b>Culasse</b>	<b>Coperchio delle punterie</b>
125. Position gasket.	125. Mettre en place le joint.	125. Montare la guarnizione.

**Demontage und Montage, Motor komplett**  
**Disassembly and reassembly of complete engine**  
**Démontage et montage moteur complet**  
**Smontaggio e rimontaggio completo del motore**

English	Français	Italiano
126. Fit cylinder head cover together with cover plate and cable harness. Tighten bolts with a torque of <b>9 ± 1 Nm</b> .	126. Monter la vis de culasse avec la tôle de recouvrement et le faisceau de câbles. Serrer les vis au couple de <b>9 ± 1 Nm</b> .	126. Montare il coperchio delle punterie completo di lamiera di protezione ed il cablaggio preassemblato. Serrare le viti con una coppia di <b>9 ±1 Nm</b> .
<b>Lube oil cooler</b>	<b>Radiateur à huile</b>	<b>Refrigeratore dell'olio lubrificante.</b>
127. Mount lube oil cooler with new gasket.	127. Monter le radiateur avec un joint neuf.	127. Montare il refrigeratore dell'olio lubrificante munito di una nuova guarnizione.
128. Tighten bolts with a torque of <b>21 ± 2 Nm</b> .	128. Serrer les vis au couple de <b>21 ± 2 Nm</b> .	128. Serrare le viti con una coppia di <b>21 ± 2 Nm</b> .
<b>Note:</b> Fit retainer for cable connector as well if any.	<b>Nota:</b> selon l'équipement du moteur monter le support de liaison des câbles.	<b>Nota:</b> Qualora sia disponibile, montare anche il supporto per il connettore dei cavi.
129. Fit both screw plugs with new Cu seals.	129. Monter les deux tubulures à visser avec un joint Cu neufs.	129. Montare ambedue i raccordi filettati muniti di nuove guarnizioni di rame.



**Deutsch**

**Werkstatthandbuch BFM 1012/E, BFM 1013/E**

126. Zylinderkopfhaube mit Abdeckblech und Kabelbaum montieren. Schrauben mit einem Drehmoment von  $9 \pm 1 \text{ Nm}$  festdrehen.

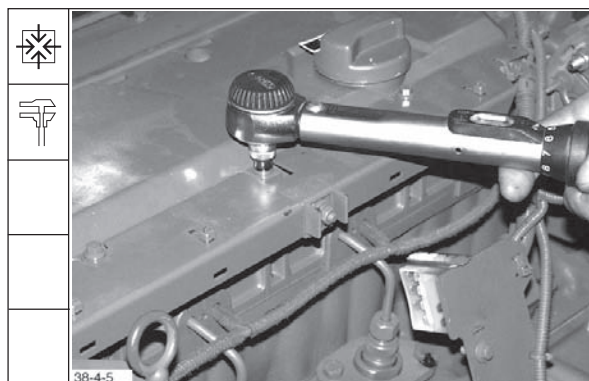

**Schmierölkühler**

127. Schmierölkühler mit neuer Dichtung anbauen.

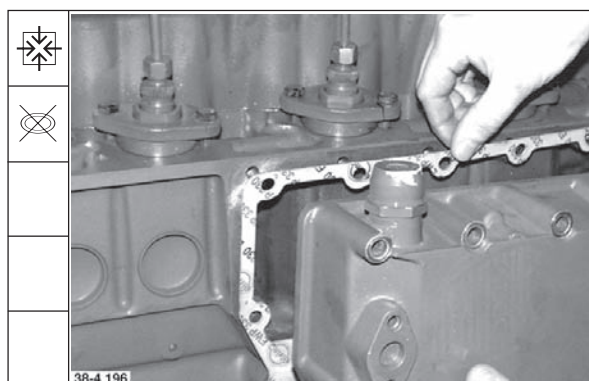

128. Schrauben mit einem Drehmoment von  $21 \pm 2 \text{ Nm}$  festdrehen.

**Hinweis:** Falls vorhanden, Halter für Kabelverbindung mitanbauen.

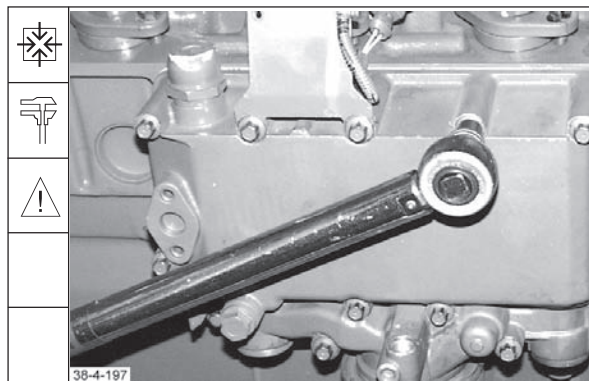

129. Beide Einschraubstutzen mit neuer Cu-Dichtung anbauen.

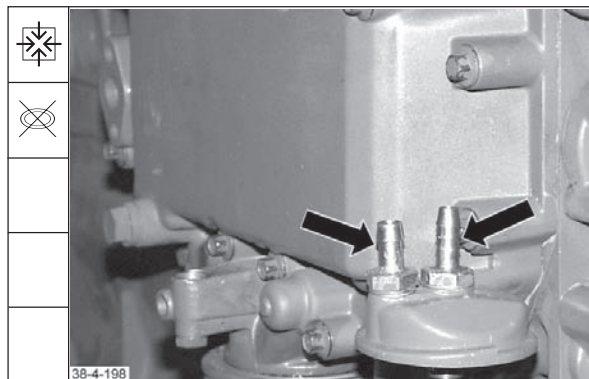

**Demontage und Montage, Motor komplett**  
**Disassembly and reassembly of complete engine**  
**Démontage et montage moteur complet**  
**Smontaggio e rimontaggio completo del motore**

Werkstatthandbuch BFM 1012/E, BFM 1013/E

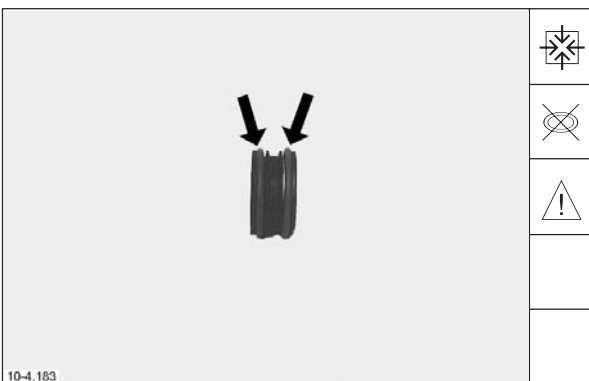
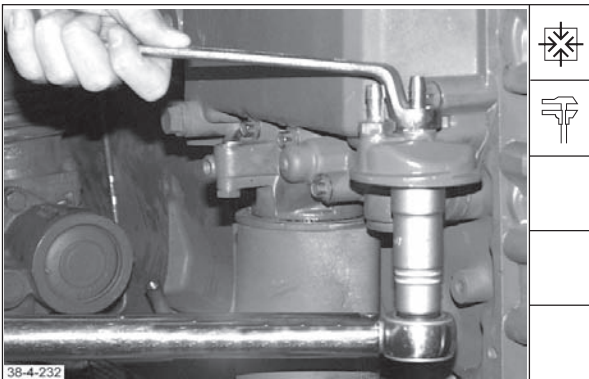

Deutsch

130. Muttern mit einem Drehmoment von **50 ± 5 Nm** festdrehen.

131. Kraftstofffilterdichtung leicht einölen.  
Kraftstofffilterpatrone handfest andrehen.

132. Ölfilterdichtung leicht einölen.  
Ölfilterpatrone handfest andrehen.

**Kühlmittelpumpe**

133. Steckstück.  
Neue Runddichtringe aufziehen.

**Hinweis:** Runddichtringe mit Montagegleitmittel **AP25N** bestreichen.

**Demontage und Montage, Motor komplett**  
**Disassembly and reassembly of complete engine**  
**Démontage et montage moteur complet**  
**Smontaggio e rimontaggio completo del motore**

English	Français	Italiano
130. Tighten nut with a torque of <b>50 ± 5 Nm</b> .	130. Serrer les écrous au couple de <b>50 ± 5 Nm</b> .	130. Serrare il dado con una coppia di <b>50 ± 5 Nm</b> .
131. Lightly oil fuel filter gasket. Secure fuel filter cartridge fingertight.	131. Huiler légèrement le joint du filtre à combustible. Serrer la cartouche filtrante à la main.	131. Oliare leggermente la guarnizione del filtro del combustibile. Serrare a mano la cartuccia del filtro del combustibile.
132. Lightly oil oil filter gasket. Secure oil filter cartridge fingertight.	132. Huiler légèrement le joint du filtre à huile. Serrer la cartouche filtrante à la main.	132. Oliare leggermente la guarnizione del filtro dell'olio. Serrare a mano la cartuccia del filtro dell'olio.
<b>Coolant pump</b>	<b>Pompe à réfrigérant</b>	<b>Pompa del liquido refrigerante</b>
133. Plug-in element Slide on O-seals.	133. Pièce d'insertion. Monter les joints toriques neufs.	133. Manicotto di collegamento ad innesto. Montare nuovi O-ring.
<b>Note:</b> Apply lubricant <b>AP25N</b> to O-seals.	<b>Nota:</b> enduire le joint torique de lubrifiant de montage <b>AP25N</b> .	<b>Nota:</b> Spalmare gli O-ring con lo speciale lubrificante <b>AP25N</b> .

**Demontage und Montage, Motor komplett**  
**Disassembly and reassembly of complete engine**  
**Démontage et montage moteur complet**  
**Smontaggio e rimontaggio completo del motore**

English	Français	Italiano
134. Press plug-in element into thermostat housing and coolant pump.	134. Insérer l'élément enfichable dans le boîtier du thermostat et la pompe à réfrigérant.	134. Innestare il manicotto di collegamento nella scatola del termostato e nella pompa del liquido refrigerante.
135. Insert new O-seals into thermostat housing.  <b>Note:</b> Apply lubricant <b>AP25N</b> to O-seals.	135. Monter le joint torique neuf dans le carter du thermostat.  <b>Nota:</b> enduire le joint torique de lubrifiant de montage <b>AP25N</b> .	135. Inserire un nuovo O-ring nella scatola del termostato.  <b>Nota:</b> Spalmare l'O-ring con lo speciale lubrificante <b>AP25N</b> .
136. Mount preassembled coolant pump with new gasket.	136. Monter la pompe à réfrigérant préassemblée avec un joint neuf.	136. Installare la pompa premontata del liquido refrigerante munita di una nuova guarnizione.
137. Tighten bolts alternately with a torque of <b>21 ± 2 Nm</b> .	137. Serrer alternativement les vis au couple de <b>21 ± 2 Nm</b> .	137. Serrare le viti alternativamente con una coppia di <b>21 ± 2 Nm</b> .

Deutsch

Werkstatthandbuch BFM 1012/E, BFM 1013/E

134. Steckstück in Thermostatgehäuse und Kühlmittelpumpe eindrücken.



135. Neuen Runddichtring in Thermostatgehäuse einsetzen.

**Hinweis:** Runddichtring mit Montagemittel **AP25N** bestreichen.

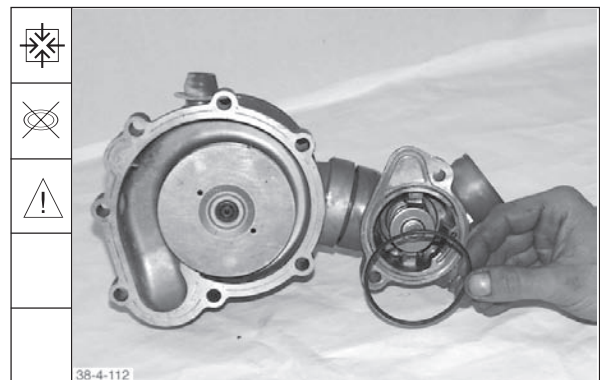

136. Vormontierte Kühlmittelpumpe mit neuer Dichtung anbauen.

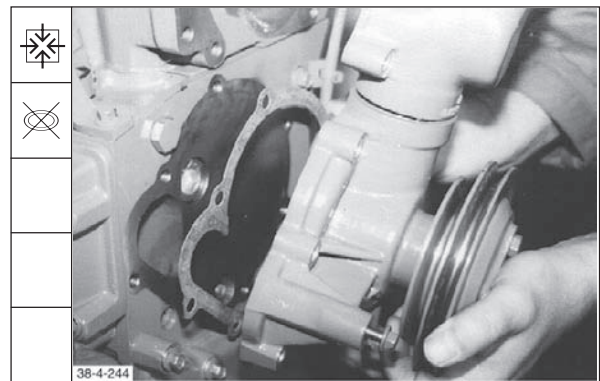

137. Schrauben wechselseitig mit einem Drehmoment von **21 ± 2 Nm** festdrehen.

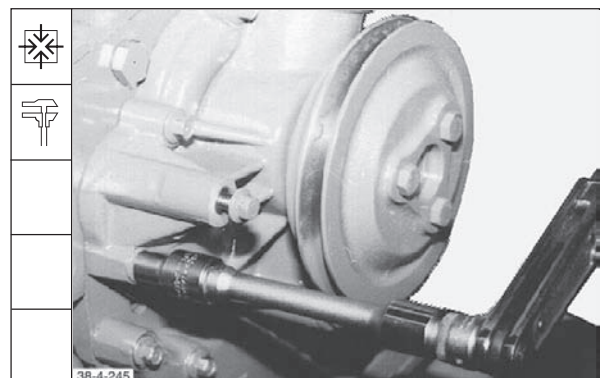



**Demontage und Montage, Motor komplett**  
**Disassembly and reassembly of complete engine**  
**Démontage et montage moteur complet**  
**Smontaggio e rimontaggio completo del motore**

Werkstatthandbuch BFM 1012/E, BFM 1013/E

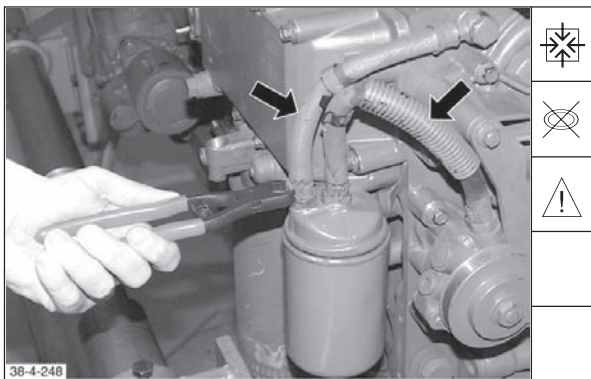
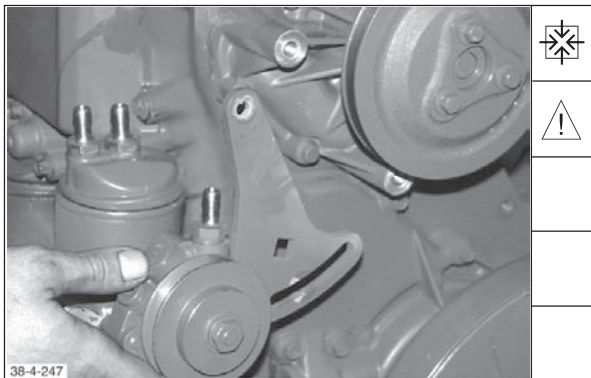
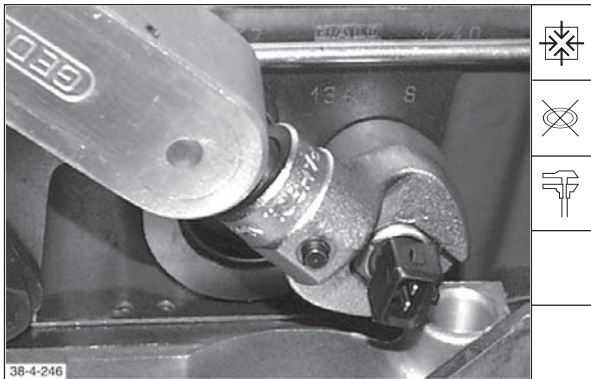

**Deutsch**

138. Kühlmitteltemperaturgeber mit neuer Dichtung und Isolierschlauch, falls vorhanden, mit einem Drehmoment von **18 ± 2 Nm** festdrehen.

**Kraftstoffpumpe**

139. Kraftstoffpumpe anbauen

**Hinweis:** Schrauben leicht andrehen.

140. Kraftstoffleitungen mit neuen Cu-Dichtungen anbauen.  
Cobrasklemmenzange benutzen.

**Hinweis:** Achtung - Gewinde für Anschluß der Zulaufleitung an der Kraftstoffpumpe ist **M16x1,5**.

**Ölansaugrohr/Ölwanne**

141. Motor 180° drehen. Ölansaugrohr mit neuer Dichtung anbauen.

**Hinweis:** Halter mitanbauen. Schrauben nicht festdrehen.

**Demontage und Montage, Motor komplett**  
**Disassembly and reassembly of complete engine**  
**Démontage et montage moteur complet**  
**Smontaggio e rimontaggio completo del motore**

English	Français	Italiano
<p>138. Fit coolant temperature sensor with new seal and insulating hose, if any, and tighten with a torque of <b>18 ± 2 Nm</b>.</p>	<p>138. Serrer au couple de <b>18 ± 2 Nm</b> le capteur de produit réfrigérant avec un joint neuf et un tuyau isolant , si le moteur en est équipé d'un.</p>	<p>138. Se è disponibile, serrare con una coppia di <b>18 ± 2 Nm</b> il sensore della temperatura del liquido lubrificante dopo averlo munito di una nuova guarnizione e di un tubo isolante.</p>
<p><b>Fuel pump</b></p> <p>139. Fit fuel pump.</p> <p><b>Note:</b> Start bolts.</p>	<p><b>Pompe à combustible</b></p> <p>139. Monter la pompe à combustible.</p> <p><b>Nota:</b> serrer légèrement les vis.</p>	<p><b>Pompa del combustibile</b></p> <p>139. Montare la pompa del combustibile.</p> <p><b>Nota:</b> Avvitare leviti a mano.</p>
<p>140. Fit fuel lines with new Cu seals. Use Cobra clamp pliers.</p> <p><b>Note:</b> Attention - thread for feed line connection on fuel pump is <b>M16x1.5</b>.</p>	<p>140. Monter les tuyauteries de combustible avec des joint Cu neufs. Utiliser la pince de serrage Cobra.</p> <p><b>Nota:</b> attention - filetage du raccord de la conduite d'arrivée à la pompe à combustible est <b>M16x1,5</b>.</p>	<p>140. Montare le tubazioni del combustibile munite di nuove guarnizioni di rame. Servirsi della pinza per morsetti Cobra.</p> <p><b>Nota:</b> Attenzione! - Il filetto del raccordo della tubazione di mandata alla pompa del combustibile è <b>M16x1,5</b>.</p>
<p><b>Oil suction pipe/oil pan</b></p> <p>141. Turn engine by 180°. Fit oil suction pipe with new gasket.</p> <p><b>Note:</b> Fit retainer as well. Do not tighten bolts.</p>	<p><b>Tube d'aspiration d'huile/carter d'huile</b></p> <p>141. Virer le moteur de 180°. Monter le tube d'aspiration d'huile en utilisant un joint neuf.</p> <p><b>Nota:</b> monter le dispositif de maintien. Ne pas serrer les vis à fond.</p>	<p><b>Tubo di aspirazione dell'olio/Coppa dell'olio</b></p> <p>141. Girare il motore di 180°. Montare il tubo di aspirazione dell'olio con una nuova guarnizione.</p> <p><b>Nota:</b> Montare contemporaneamente anche il supporto. Non serrarne per ora le viti.</p>

**Demontage und Montage, Motor komplett**  
**Disassembly and reassembly of complete engine**  
**Démontage et montage moteur complet**  
**Smontaggio e rimontaggio completo del motore**

English	Français	Italiano
142. Order of tightening.  1. Bolts of oval flange 2. Retainer of oil suction pipe with a torque of <b>21 ± 2 Nm</b> .	142. Ordre de serrage.  1. Vis de la bride ovale 2. Serrer le support de maintien du tube d'aspiration d'huile au couple de <b>21 ± 2 Nm</b> .	142. Sequenza di serraggio delle viti.  I – Vite della flangia ovale II – Supporto del tubo di aspirazione dell'olio vanno serrati con una coppia di <b>21 ± 2 Nm</b> .
143. Cut off projecting gasket.	143. Sectionner la partie du joint qui dépasse.	143. Tagliare la parte di guarnizione che sporge.
144. Fill up joints of oil pan sealing surface with <b>Deutz DW 47</b> .	144. Remplir les joints du plan de joint du carter d'huile de <b>Deutz DW 47</b> .	144. Riempire con mastice <b>Deutz DW 47</b> le fessure della superficie di tenuta per la coppa dell'olio.
145. Position new gasket on crankcase.	145. Placer un joint neuf sur le bloc moteur.	145. Disporre una nuova guarnizione sul bordo del basamento motore.



Deutsch

Werkstatthandbuch BFM 1012/E, BFM 1013/E

142. Reihenfolge beim Festdrehen.

1. Schrauben des Ovalflansches
2. Halter des Ölansaugrohres mit einem Drehmoment von  $21 \pm 2 \text{ Nm}$  festdrehen.

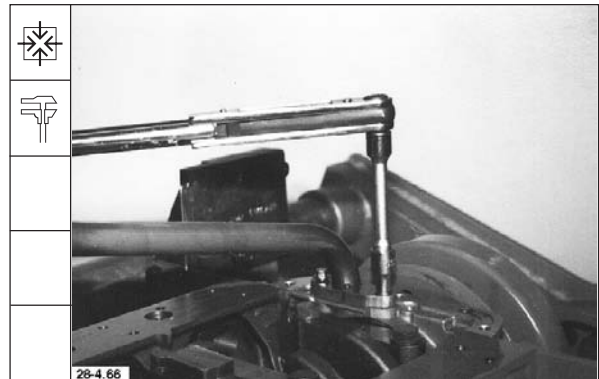

143. Überstehende Dichtung abschneiden.

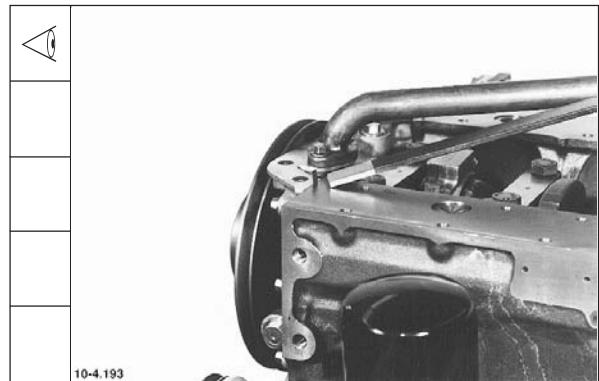

144. Fugen der Ölwanndichtfläche mit **Deutz DW 47** auffüllen.

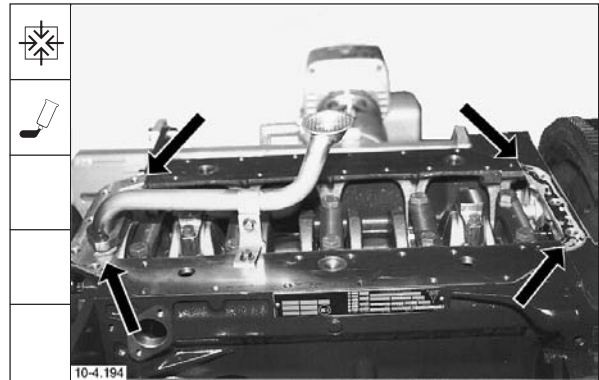

145. Neue Dichtung auf das Kurbelgehäuse auflegen.



**Demontage und Montage, Motor komplett**  
**Disassembly and reassembly of complete engine**  
**Démontage et montage moteur complet**  
**Smontaggio e rimontaggio completo del motore**

Werkstatthandbuch BFM 1012/E, BFM 1013/E

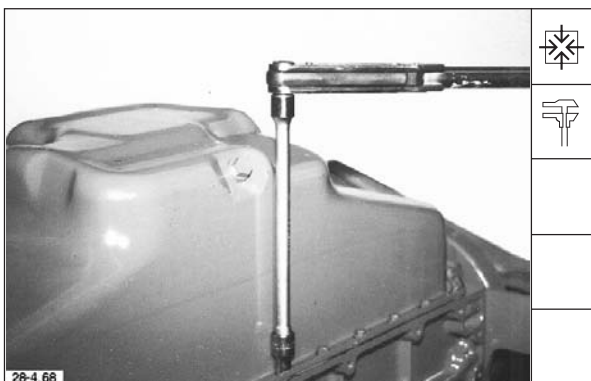
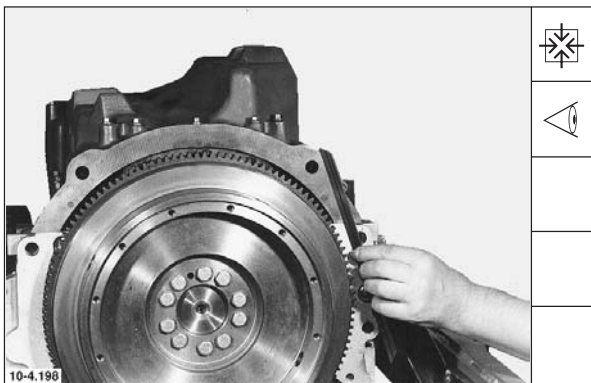
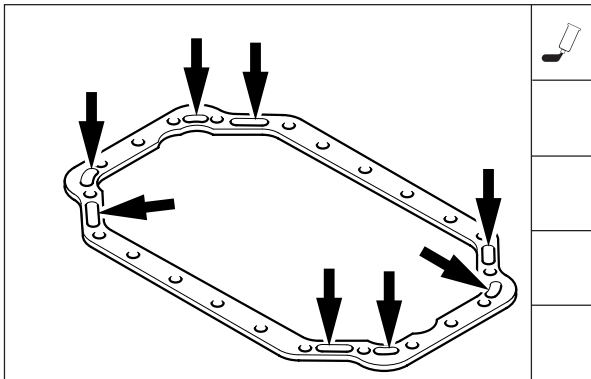

**Deutsch**

146. Bei Dichtung für Blechölwanne alle Aussparungen mit **Deutz DW 47** auffüllen.

147. Bei Blechölwanne:  
Ölwanne anbauen.

**Hinweis:** Markierte Einbaulage beachten.

148. Bei Gußölwanne:  
Ölwanne anbauen und zum Räderkasten-  
deckel ausrichten.

149. Schrauben gleichmäßig/wechelseitig mit  
einem Drehmoment von **21 ± 2 Nm** bei  
Blechölwanne oder  
**29 ± 2 Nm** bei Gußölwanne festdrehen.

**Demontage und Montage, Motor komplett**  
**Disassembly and reassembly of complete engine**  
**Démontage et montage moteur complet**  
**Smontaggio e rimontaggio completo del motore**

English	Français	Italiano
146. Fill up all recesses in the gasket for the sheet metal oil pan with <b>Deutz DW 47</b> .	146. En présence du joint du carter d'huile en tôle remplir tous les évidements de <b>Deutz DW 47</b> .	146. Se la guarnizione è per una coppa dell'olio in lamiera, riempirne tutte le rientranze col mastice <b>Deutz DW 47</b> .
147. With sheet metal oil pan: Mount oil pan.  <b>Note:</b> Watch marked installation position.	147. En présence d'un carter d'huile en tôle : monter le carter d'huile.  <b>Nota:</b> veiller au sens de montage indiqué.	147. Se la coppa dell'olio è di lamiera: montare la coppa dell'olio.  <b>Nota:</b> Rispettare la posizione di montaggio segnata.
148. With cast oil pan: Mount oil pan and align relative to timing chest cover.	148. En présence d'un carter d'huile en fonte: Monter le carter et l'aligner par rapport au couvercle du carter de distribution.	148. Se la coppa dell'olio è di ghisa: montare la coppa dell'olio, allineandola col coperchio della scatola della distribuzione.
149. Tighten bolts uniformly/alternately with a torque of <b>21 ± 2 Nm</b> with sheet metal oil pan or with <b>29 ± 2 Nm</b> with cast oil pan.	149. Serrer uniformément l'une après l'autre les vis au couple de <b>21 ± 2 Nm</b> pour le carter d'huile en tôle ou au couple de <b>29 ± 2 Nm</b> pour le carter d'huile en fonte.	149. Serrare le viti uniformemente / alternativamente con una coppia di <b>21 ± 2 Nm</b> nel caso di una coppa di lamiera e con una coppia di <b>29 ± 2 Nm</b> nel caso di una coppa di ghisa.

**Demontage und Montage, Motor komplett**  
**Disassembly and reassembly of complete engine**  
**Démontage et montage moteur complet**  
**Smontaggio e rimontaggio completo del motore**

English	Français	Italiano
<p><b>Governor</b></p> <p>150. Apply sealing compound <b>Deutz DW 48</b> to governor. Sealing string <b>dia.: 1.5 + 0.5 mm</b></p> <p><b>Note:</b> Sealing surface must be free of oil and grease.</p> <p>151. Turn engine by 180°, mount governor.</p> <p>152. Tighten bolts in the order 1-2-3-4-5 with a torque of <b>17 ± 1.5 Nm</b>.</p> <p>153. Fit new O-seal to cover and grease lightly.</p>	<p><b>Régulateur</b></p> <p>150. Enduire de pâte d'étanchéité <b>Deutz DW 48</b> le régulateur. Epaisseur du fil d'étanchéité: <b>ø 1,5 + 0,5 mm</b></p> <p><b>Nota:</b> le plan de joint doit être exempt d'huile et de graisse.</p> <p>151. Virer le moteur de 180° et monter le régulateur.</p> <p>152. Serrer les vis au couple de <b>17 ± 1,5 Nm</b> dans l'ordre 1-2-3-4-5.</p> <p>153. Monter le joint torique neuf sur le couvercle de fermeture et le graisser légèrement.</p>	<p><b>Regolatore</b></p> <p>150. Applicare il mastice <b>Deutz DW 48</b> sulle superfici di tenuta del regolatore segnate in neretto nello schizzo a fianco. Spessore del filo di mastice <b>ø 1,5 + 0,5 mm</b></p> <p><b>Nota:</b> La superficie di tenuta deve essere esenta da olio e grassi.</p> <p>151. Girare il motore di 180°. Montare il regolatore.</p> <p>152. Serrare le viti nella sequenza 1-2-3-4-5 con una coppia di <b>17 ± 1,5 Nm</b>.</p> <p>153. Montare un nuovo O-ring sul tappo e spalmarlo leggermente di grasso.</p>

**Deutsch**

**Werkstatthandbuch BFM 1012/E, BFM 1013/E**

**Regler**

150. Dichtmittel **Deutz DW 48** auf Regler auftragen.  
Dichtfadenstärke  $\varnothing 1,5 + 0,5$  mm

**Hinweis:** Dichtfläche muß öl- und fettfrei sein.

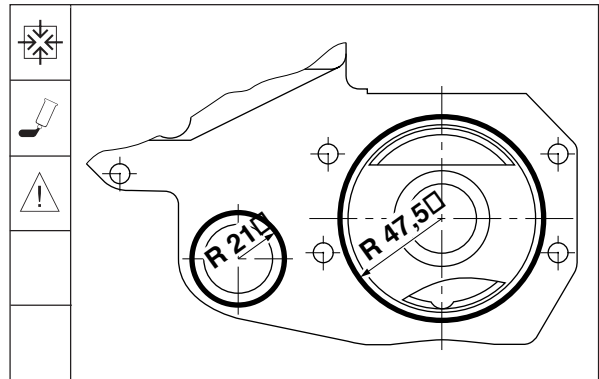

151. Motor um 180° drehen. Regler anbauen.

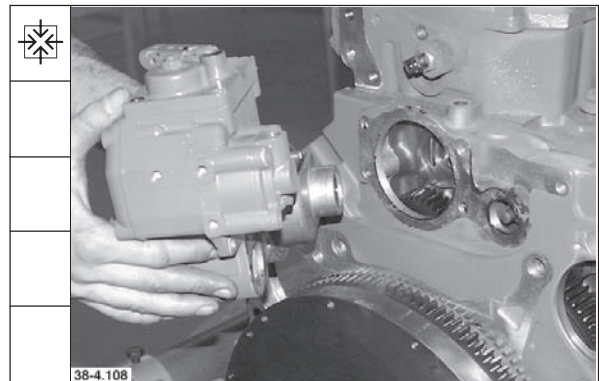

152. Schrauben in der Reihenfolge 1-2-3-4-5 mit einem Drehmoment von  $17 \pm 1,5$  Nm festdrehen.

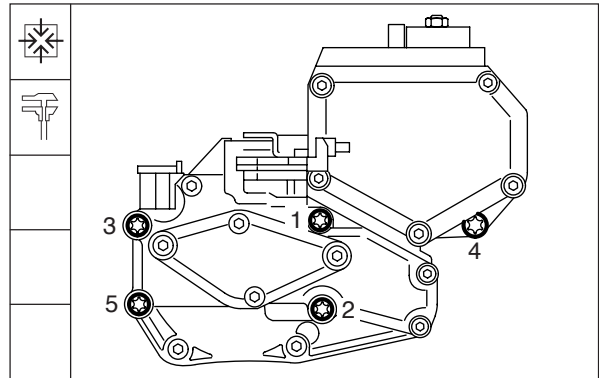

153. Neuen Runddichtring auf Verschlussdeckel montieren und leicht einfetten.



**Demontage und Montage, Motor komplett**  
**Disassembly and reassembly of complete engine**  
**Démontage et montage moteur complet**  
**Smontaggio e rimontaggio completo del motore**

**Werkstatthandbuch BFM 1012/E, BFM 1013/E**

**Deutsch**

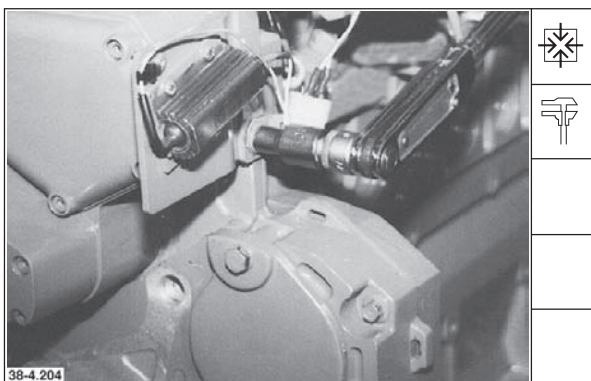
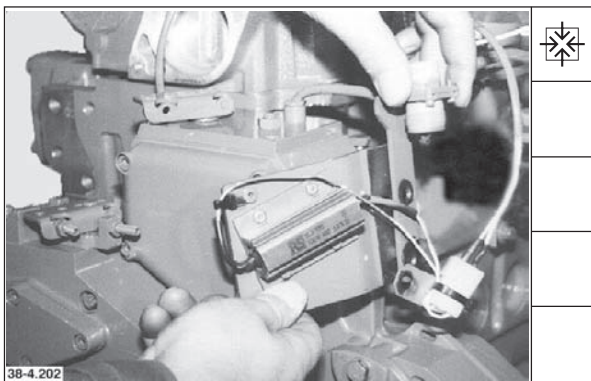
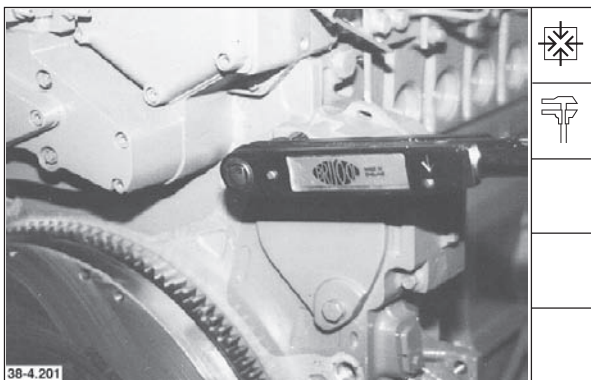
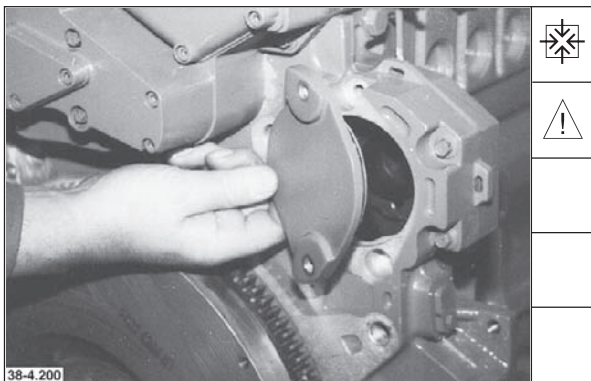

154. Verschlußdeckel montieren.

**Hinweis:** Auf Abstandshülsen achten.

155. Schrauben mit einem Drehmoment von **21 ± 2 Nm** festdrehen.

156. Halteplatte an Regler anbauen.

157. Schrauben mit einem Drehmoment von **21 ± 2 Nm** festdrehen.

**Demontage und Montage, Motor komplett**  
**Disassembly and reassembly of complete engine**  
**Démontage et montage moteur complet**  
**Smontaggio e rimontaggio completo del motore**

English	Français	Italiano
154. Fit cover. <b>Note:</b> Watch out for spacer sleeves.	154. Monter le couvercle de fermeture. <b>Nota:</b> veiller aux douilles d'écartement.	154. Montare il tappo. <b>Nota:</b> Fare attenzione alle bussole distanziatrici.
155. Tighten bolts with a torque of <b>21 ± 2 Nm.</b>	155. Serrer les vis au couple de <b>21 ± 2 Nm.</b>	155. Serrare le viti con una coppia di <b>21 ± 2Nm.</b>
156. Fit retaining plate to governor.	156. Monter plaque d'appui sur régulateur.	156. Montare la piastra di supporto sul regolatore.
157. Tighten bolts with a torque of <b>21 ± 2 Nm.</b>	157. Serrer les vis au couple de <b>21 ± 2 Nm.</b>	157. Serrare le viti con una coppia di <b>21 ± 2Nm.</b>

**Demontage und Montage, Motor komplett**  
**Disassembly and reassembly of complete engine**  
**Démontage et montage moteur complet**  
**Smontaggio e rimontaggio completo del motore**

English	Français	Italiano
<b>Cable harness</b>	<b>Faisceau de câbles</b>	<b>Cablaggio preassemblato</b>
158. Fit cable lug to governor.	158. Monter cosse de câble sur le régulateur.	158. Inserire il terminale dei cavi sul regolatore.
159. Fit cable lug to shutdown solenoid.	159. Monter cosse de câble sur l'électroaimant d'arrêt.	159. Inserire il terminale dei cavi sull'elettromagnete di arresto.
160. Put together glow plug cable couplers.	160. Assembler coupleurs de câble de bougie de préchauffage.	160. Connettere assieme gli accoppiatori dei cavi delle candlette di preriscaldamento.



**Deutsch**

**Werkstatthandbuch BFM 1012/E, BFM 1013/E**

**Kabelbaum**

158. Kabelschuh an Regler anbauen.

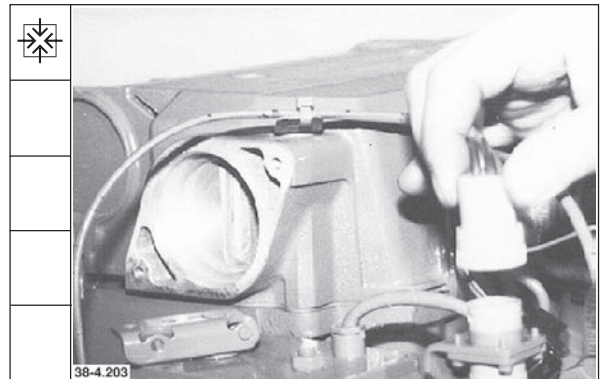

159. Kabelschuh an Abstellmagnet anbauen.

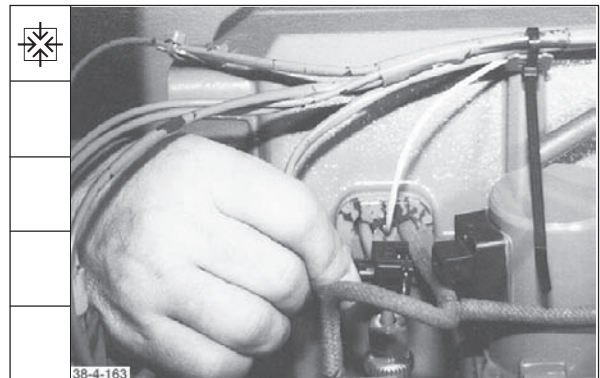

160. Glühkerzen-Kabelkupplungen zusammenstecken.



# Demontage und Montage, Motor komplett Disassembly and reassembly of complete engine Démontage et montage moteur complet Smontaggio e rimontaggio completo del motore

## Werkstatthandbuch BFM 1012/E, BFM 1013/E

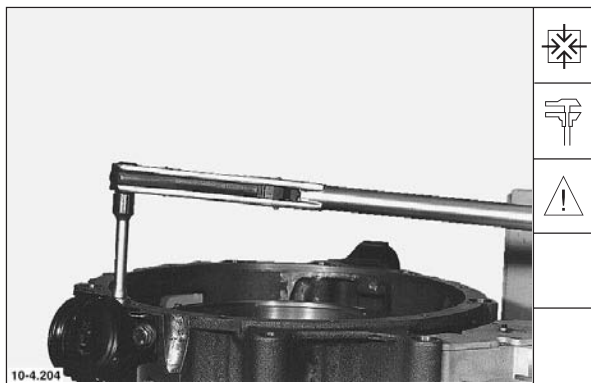

## Deutsch

### Anschlußgehäuse

(Darstellung BFM 1012)

161. Motor 90° drehen. Anschlußgehäuse anbauen.

**Hinweis:** Auf Vorhandensein der Zentrierhülsen achten.

162. Schrauben nach Anziehvorschrift festdrehen.

Schrauben M 12 = **99 ± 10 Nm**

Schrauben M 16 = **243 ± 25 Nm**

**Hinweis:** Torx Werkzeug verwenden.

E 14 lange Ausführung

E 20 lange Ausführung

163. Abdeckblech anbauen.

**Demontage und Montage, Motor komplett**  
**Disassembly and reassembly of complete engine**  
**Démontage et montage moteur complet**  
**Smontaggio e rimontaggio completo del motore**

English	Français	Italiano
<b>Adapter housing</b> (BFM 1012 shown here)	<b>Carter d'adaptation</b> (Illustration BFM 1012)	<b>Campana di collegamento</b> (nella fotografia BFM 1012)
161. Turn engine by 90°. Mount adapter housing.	161. Virer le moteur de 90° puis monter le carter d'adaptation.	161. Girare il motore di 90°. Montare la campana di collegamento.
<b>Note:</b> Make sure that centering sleeve are fitted.	<b>Nota:</b> veiller à la présence des douilles de centrage.	<b>Nota:</b> Controllare che ci siano le bussole di centraggio.
162. Tighten bolts according to specification.	162. Serrer les vis selon les préconisations de serrage :	162. Serrare le viti in base alle prescrizioni.
M 12 = <b>99 ± 10 Nm</b> M 16 = <b>243 ± 25 Nm</b>	Vis M 12 = <b>99 ± 10 Nm</b> Vis M 16 = <b>243 ± 25 Nm</b>	Viti M 12 = <b>99 ± 10 Nm</b> Viti M 16 = <b>243 ± 25 Nm</b>
<b>Note:</b> Use Torx tool. E 14 long version E 20 long version	<b>Nota:</b> utiliser les outils Torx E 14 modèle long E 20 modèle long	<b>Nota:</b> Far uso degli attrezzi Torx. E 14 versione lunga E 20 versione lunga
163. Mount cover plate.	163. Monter la tôle de recouvrement.	163. Montare la lamiera di protezione

**Demontage und Montage, Motor komplett**  
**Disassembly and reassembly of complete engine**  
**Démontage et montage moteur complet**  
**Smontaggio e rimontaggio completo del motore**

English	Français	Italiano
<p><b>Starter</b></p> <p>164. Mount starter. Tighten bolts with a torque of <b>70 Nm</b>.</p> <p><b>Note:</b> Tighten collar nut, if any, with a torque of <b>40 Nm</b>.</p> <p>165. Fit cable and fastening clips.</p>	<p><b>Démarreur</b></p> <p>164. Monter le démarreur. Serrer les vis au couple de <b>70 Nm</b>.</p> <p><b>Nota:</b> selon l'équipement du moteur serrer l'écrou à embase au couple de <b>40 Nm</b>.</p> <p>165. Monter le câble et les colliers de fixation.</p>	<p><b>Motorino d'avviamento</b></p> <p>164. Montare il motorino d'avviamento. Serrare le viti con una coppia di <b>70 Nm</b>.</p> <p><b>Nota:</b> Se esiste, serrare il dado con spallamento con una coppia di <b>40 Nm</b>.</p> <p>165. Montare il cavo con le fascette di fissaggio.</p>
<p><b>Breather pipe</b></p> <p>166. Fit breather pipe with new Cu seals.</p> <p>167. Tighten bolts for breather pipe with a torque of <b>11 ± 1 Nm</b>.</p>	<p><b>Conduite de dégazage</b></p> <p>166. Monter la conduite de dégazage avec des joints d'étanchiété Cu neufs.</p> <p>167. Serrer la vis de la conduite de degazage au couple de <b>11 ± 1 Nm</b>.</p>	<p><b>Tubazione di sfiato</b></p> <p>166. Montare la tubazione di sfiato con nuovi anelli di tenuta in rame.</p> <p>167. Serrare la vite della tubazione di sfiato con una coppia di <b>11 ± 1 Nm</b>.</p>

Deutsch

Werkstatthandbuch BFM 1012/E, BFM 1013/E

Starter

164. Starter anbauen. Schrauben mit einem Drehmoment von **70 Nm** festdrehen.

**Hinweis:** Falls vorhanden, Bundmutter mit einem Drehmoment von **40 Nm** festdrehen.



165. Kabel und Befestigungsschellen anbauen.



Entlüftungsleitung

166. Entlüftungsleitung mit neuen Cu-Dichtungen anbauen.

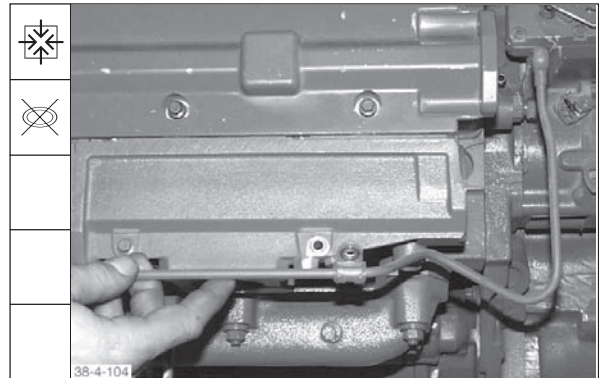

167. Schraube für Entlüftungsleitung mit einem Drehmoment von **11 ± 1 Nm** festziehen.

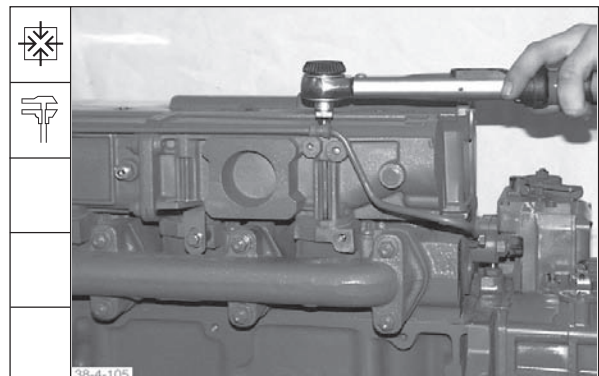

**Demontage und Montage, Motor komplett**  
**Disassembly and reassembly of complete engine**  
**Démontage et montage moteur complet**  
**Smontaggio e rimontaggio completo del motore**

Werkstatthandbuch BFM 1012/E, BFM 1013/E

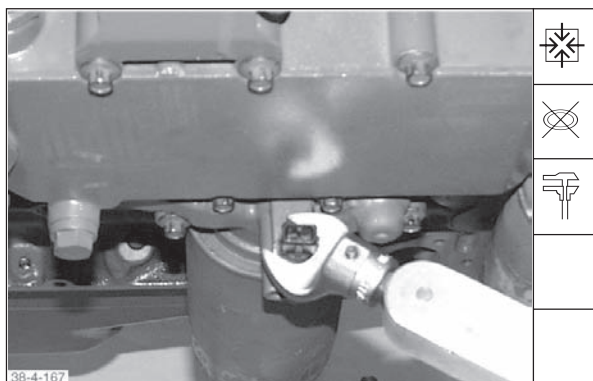
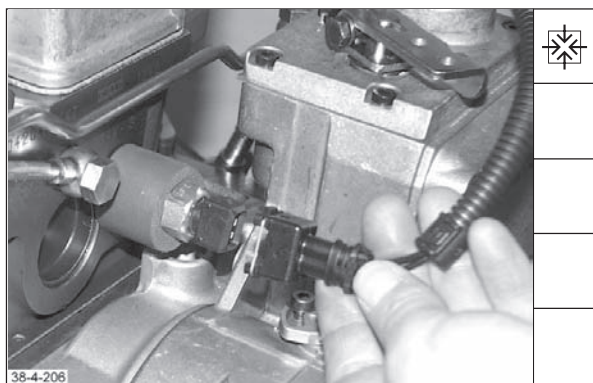
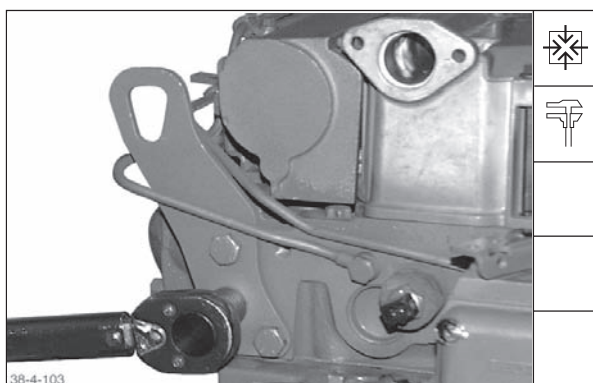
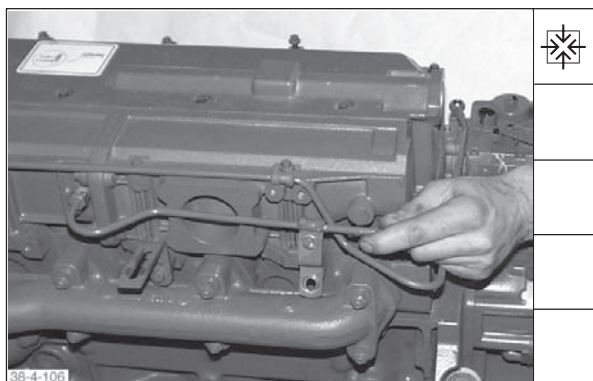

**Deutsch**

168. Luftleitung zum LDA anbauen.

169. Transportösen anbauen. Schrauben mit einem Drehmoment von **47 ± 4 Nm** festdrehen.

170. Kabelschuh an Kühlmitteltemperaturgeber anbauen.

**Öldruckschalter**

171. Öldruckschalter mit neuem Cu- Dichtring anbauen und mit einem Drehmoment von **18 ± 2 Nm** festdrehen.

**Demontage und Montage, Motor komplett**  
**Disassembly and reassembly of complete engine**  
**Démontage et montage moteur complet**  
**Smontaggio e rimontaggio completo del motore**

English	Français	Italiano
168. Fit air pipe to manifold pressure compensator (LDA)	168. Monter la conduite d'air du correcteur de débit (LDA).	168. Montare la condotta d'aria al correttore di mandata (LDA)
169. Fit lifting lugs. Tighten bolts with a torque of <b>47 ± 4 Nm</b> .	169. Monter les oeilletons de manutention et serrer les vis au couple de <b>47 ± 4 Nm</b> .	169. Montare gli occhioni di trasporto. Serrare le viti con una coppia di <b>47 ± 4 Nm</b> .
170. Fit cable lug to coolant temperature sensor.	170. Monter la cosse de câble sur la sonde de température de réfrigérant.	170. Collegare il cavo al sensore della temperatura del liquido refrigerante.
<b>Oil pressure switch</b>	<b>Manocontact de pression d'huile</b>	<b>Interruttore pressostatico dell'olio.</b>
171. Fit oil pressure switch with new Cu seal and tighten with a torque of <b>18 ± 2 Nm</b> .	171. Monter le manocontact de pression d'huile avec un joint d'étanchéité Cu neuf et serrer au couple de <b>18 ± 2 Nm</b> .	171. Montare l'interruttore pressostatico dell'olio con un nuovo anello di tenuta in rame e serrarlo con una coppia di <b>18 ± 2 Nm</b> .



**Demontage und Montage, Motor komplett**  
**Disassembly and reassembly of complete engine**  
**Démontage et montage moteur complet**  
**Smontaggio e rimontaggio completo del motore**

English	Français	Italiano
<p>172. Fit cable lug to oil pressure switch.</p>	<p>172. Monter la cosse de câble sur le manocontact de pression d'huile.</p>	<p>172. Collegare il terminale del cavo all'interruttore pressostatico dell'olio.</p>
<p><b>Crankcase breather</b></p>	<p><b>Event de carter</b></p>	<p><b>Sfiato della incastellatura</b></p>
<p>173. Assemble crankcase breather.</p>	<p>173. Compléter l'assemblage de l'évent de carter.</p>	<p>173. Assemblare il dispositivo di sfiato dell'incastellatura.</p>
<p>Order of parts assembly:</p>	<p>Suite du montage:</p>	<p>Sequenza di montaggio:</p>
<p>1 Seal</p>	<p>1 Joint</p>	<p>1. Guarnizione</p>
<p>2 Pressure control valve</p>	<p>2 Soupape de régulation de pression</p>	<p>2. Valvola regolatrice della pressione</p>
<p>3 Rubber sleeve</p>	<p>3 Manchon en caoutchouc</p>	<p>3. Manicotto di gomma</p>
<p><b>Note:</b> Pay attention to positioning aids on pressure control valve and rubber sleeve. Slide on rubber sleeve as far as it will go.</p>	<p><b>Nota:</b> veiller aux points de positionnement sur la soupape de régulation de pression et de manchon en caoutchouc. Insérer le manchon en caoutchouc jusqu'en position de butée.</p>	<p><b>Nota:</b> Fare attenzione ai sistemi di posizionamento del manicotto di gomma e della valvola regolatrice di pressione. Il manicotto di gomma deve venire infilato spingendolo fino a battuta.</p>
<p>174. Press rubber sleeve as far as it will go into timing chest bore. Fit pressure control valve to cylinder head.</p>	<p>174. Enfoncer le manchon en caoutchouc dans l'alésage de la distribution puis monter la soupape de régulation de pression sur la culasse.</p>	<p>174. Far entrare il manicotto di gomma nel foro della scatola della distribuzione fino a battuta. La valvola regolatrice di pressione va montata sul lato della testa cilindri.</p>
<p><b>Note:</b> Lightly grease receiving bore in cylinder head.</p>	<p><b>Nota:</b> huiler légèrement l'alésage de positionnement dans la culasse.</p>	<p><b>Nota:</b> Spalmare leggermente con grasso il foro d'alloggiamento sulla testa cilindri.</p>
<p>175. Tighten bolts with a torque of <b>8,5 ± 1 Nm.</b></p>	<p>175. Serrer les vis au couple de <b>8,5 ± 1 Nm.</b></p>	<p>175. Serrare le viti con una coppia di <b>8,5 ± 1 Nm.</b></p>



Deutsch

Werkstatthandbuch BFM 1012/E, BFM 1013/E

172. Kabelschuh an Öldruckschalter anbauen.

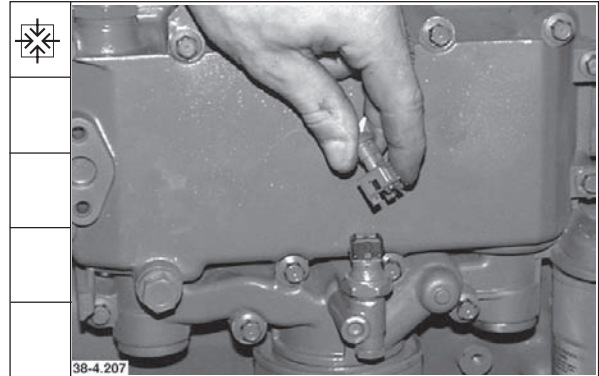

Kurbelgehäuseentlüftung

173. Kurbelgehäuseentlüftung komplettieren.

Folge der Einzelmontage:

- 1 Dichtung
- 2 Druckregelventil
- 3 Gummimuffe

**Hinweis:** Auf Positionierhilfen an Druckregelventil und Gummimuffe achten. Gummimuffe bis Anschlag aufschieben.

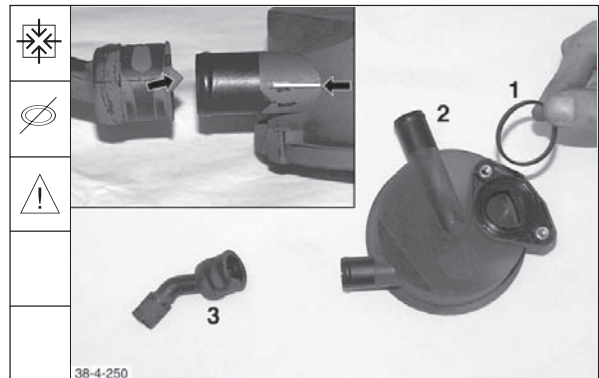

174. Gummimuffe bis zum Anschlag in die Räderkastenbohrung eindrücken. Druckregelventil an Zylinderkopf anbauen.

**Hinweis:** Aufnahmebohrung im Zylinderkopf leicht einfetten.

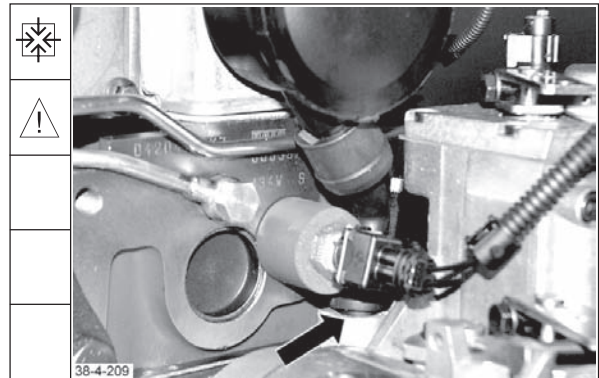

175. Schrauben mit einem Drehmoment von  $8,5 \pm 1 \text{ Nm}$  festdrehen.

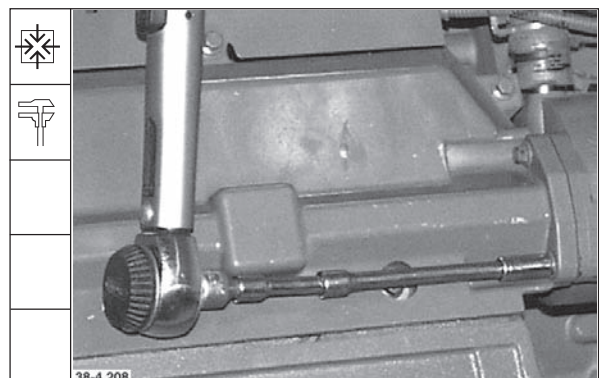

**Demontage und Montage, Motor komplett**  
**Disassembly and reassembly of complete engine**  
**Démontage et montage moteur complet**  
**Smontaggio e rimontaggio completo del motore**

Werkstatthandbuch BFM 1012/E, BFM 1013/E

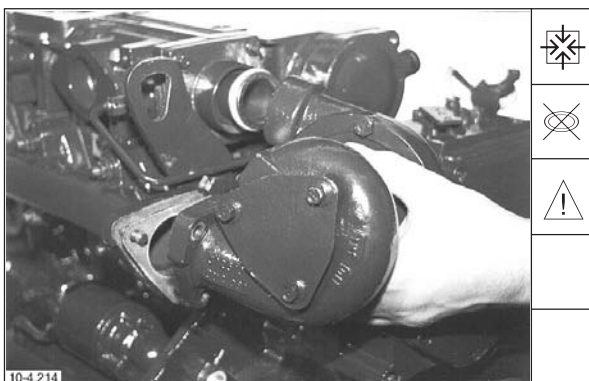
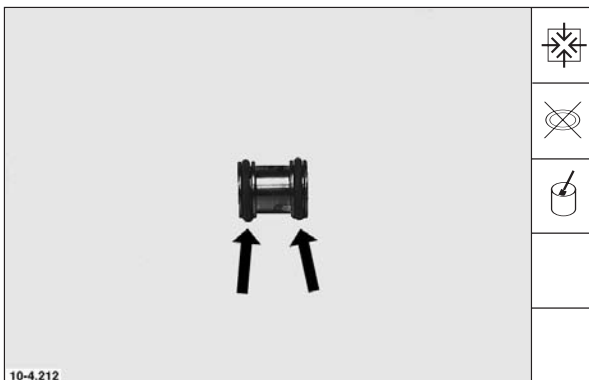
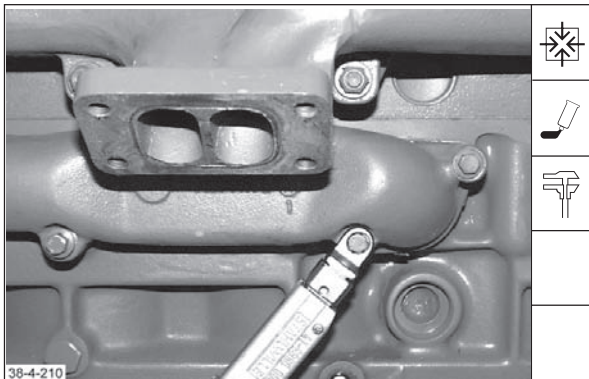

Deutsch

**Kühlmittelrohr**

176. Kühlmittelrohr mit Dichtmittel **Deutz DW 67** anbauen. Schrauben mit einem Drehmoment von **21 ± 2 Nm** festdrehen.

**Abgasturbolader BFM 1012**  
**Schwungradseite**

177. Zwischenstück

Neue Runddichtringe aufziehen und fetten.

178. Zwischenstück bis Anschlag eindrücken.

179. Abgasturbolader mit neuer Dichtung anbauen.

**Hinweis:** Stiftschrauben mit **Deutz S1** Never Seize Paste einstreichen.

**Demontage und Montage, Motor komplett**  
**Disassembly and reassembly of complete engine**  
**Démontage et montage moteur complet**  
**Smontaggio e rimontaggio completo del motore**

English	Français	Italiano
<p><b>Coolant pipe</b></p> <p>176. Mount coolant pipe with sealing compound <b>Deutz DW 67</b>. Tighten bolts with a torque of <b>21 ± 2 Nm</b>.</p>	<p><b>Conduite de réfrigérant</b></p> <p>176. Monter la conduite de réfrigérant avec de la pâte d'étanchéité <b>Deutz DW 67</b>. Serrer les vis au couple de <b>21 ± 2 Nm</b>.</p>	<p><b>Condotto del liquido refrigerante.</b></p> <p>176. Montare il condotto del liquido refrigerante facendo uso dell'ermetico <b>Deutz DW 67</b>. Serrare le viti con una coppia di <b>21 ± 2 Nm</b>.</p>
<p><b>Exhaust turbocharger BFM 1012 Flywheel end</b></p> <p>177. <u>Adapter</u></p> <p style="padding-left: 40px;">Slide on new O-seals and grease.</p> <p>178. Press in adapter as far as it will go.</p> <p>179. Mount exhaust turbocharger with new gasket.</p> <p><b>Note:</b> Apply <b>Deutz S1</b> Never Seize paste to studs.</p>	<p><b>Turbocompresseur sur échappement BFM 1012. Côté volant moteur</b></p> <p>177. <u>Pièce intermédiaire</u></p> <p style="padding-left: 40px;">Monter des joints toriques neufs et les graisser.</p> <p>178. Introduire la pièce intermédiaire jusqu'en position de butée.</p> <p>179. Monter le turbocompresseur avec un joint neuf.</p> <p><b>Nota:</b> enduire les goujons filetés de pâte d'étanchéité <b>Deutz S1</b> Never Seize.</p>	<p><b>Turbocompressore BFM 1012 Montaggio lato volano</b></p> <p>177. <u>Giunto intermedio</u></p> <p style="padding-left: 40px;">Montare nuovi O-ring e spalmarli di grasso.</p> <p>178. Introdurre fino a battuta il giunto intermedio.</p> <p>179. Montare il turbocompressore munito di una nuova guarnizione.</p> <p><b>Nota:</b> Spalmare i prigionieri con la pasta <b>Deutz S1</b> Never seize.</p>

**Demontage und Montage, Motor komplett**  
**Disassembly and reassembly of complete engine**  
**Démontage et montage moteur complet**  
**Smontaggio e rimontaggio completo del motore**

English	Français	Italiano
<p>180. Tighten nuts with a torque of <b>21 ± 2 Nm</b>.</p>	<p>180. Serrer les écrous au couple de <b>21 ± 2 Nm</b>.</p>	<p>180. Serrare i dadi con una coppia di <b>21 ± 2 Nm</b>.</p>
<p><b>Exhaust turbocharger BFM 1013</b> <b>Central arrangement</b></p>	<p><b>Turbocompresseur sur échappement</b> <b>BFM 1013</b> <b>Position milieu</b></p>	<p><b>Turbocompressore BFM 1013</b> <b>Montaggio centrale</b></p>
<p>181. Mount exhaust turbocharger with new gasket.</p>	<p>181. Monter le turbocompresseur avec un joint neuf.</p>	<p>181. Montare il turbocompressore munito di una nuova guarnizione</p>
<p><b>Note:</b> Apply <b>Deutz S1</b> Never Seize paste to bolts.</p>	<p><b>Nota:</b> enduire les goujons filetés de pâte d'étanchéité <b>Deutz S1</b>.</p>	<p><b>Nota:</b> Spalmare i prigionieri con la pasta <b>Deutz S1</b> Never seize.</p>
<p>182. Tighten bolts according to specification. Bolts M8 <b>21 ± 2 Nm</b> or Bolts M10 <b>40.5 ± 4 Nm</b></p>	<p>182. Serrer les vis selon les préconisations de serrage vis M8 <b>21 ± 2 Nm</b> ou vis M10 <b>40,5 ± 4 Nm</b></p>	<p>182. Serrare le viti in base alle prescrizioni. Viti M8 <b>21 ± 2 Nm</b> oppure viti M10 <b>40,5 ± 4 Nm</b></p>
<p><b>Oil return pipe/pressure oil pipe</b> <b>BFM 1012</b></p>	<p><b>Tube de retour d'huile/conduite</b> <b>d'huile sous pression BFM 1012</b></p>	<p><b>Tubo di ritorno dell'olio/Tubazione di</b> <b>mandata dell'olio BFM 1012</b></p>
<p>183. Slide on new O-seals and grease.</p>	<p>183. Monter un joint torique neuf et le graisser.</p>	<p>183. Montare nuovi O-ring ed ingrassarli.</p>

**Deutsch**

**Werkstatthandbuch BFM 1012/E, BFM 1013/E**

180. Muttern mit einem Drehmoment von **21 ± 2 Nm** festdrehen.

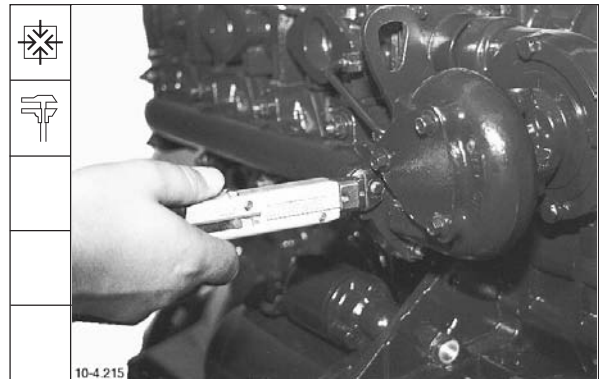

**Abgasturbolader BFM 1013**  
**Mittig**

181. Abgasturbolader mit neuer Dichtung anbauen.

**Hinweis:** Schrauben mit **Deutz S1** Never Seize Paste einstreichen.

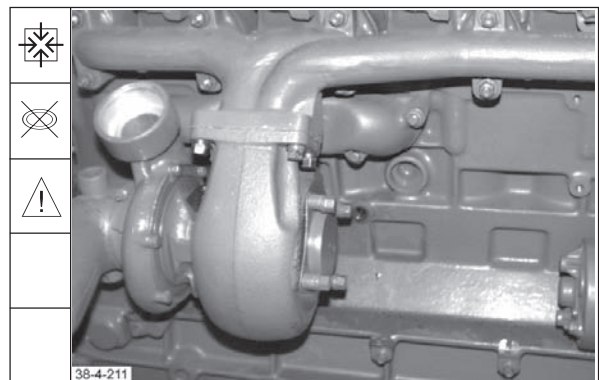

182. Schrauben nach Anziehvorschrift festdrehen.  
 Schrauben M8 **21 ± 2 Nm**  
 oder  
 Schrauben M10 **40,5 ± 4 Nm**

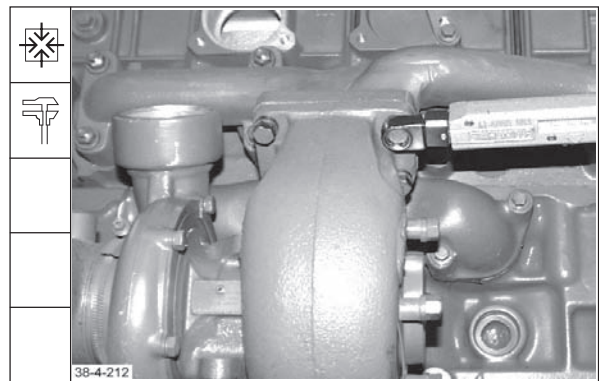

**Ölrücklaufrohr/Druckölleitung BFM 1012**

183. Neue Runddichtringe aufziehen und fetten.

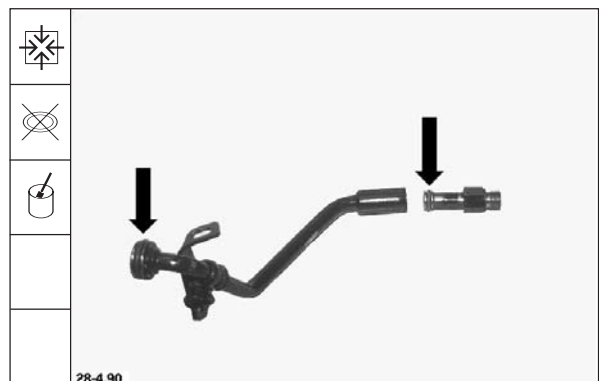



**Demontage und Montage, Motor komplett**  
**Disassembly and reassembly of complete engine**  
**Démontage et montage moteur complet**  
**Smontaggio e rimontaggio completo del motore**

**Werkstatthandbuch BFM 1012/E, BFM 1013/E**

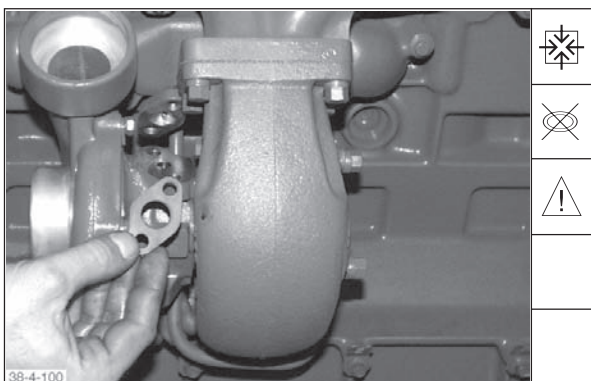
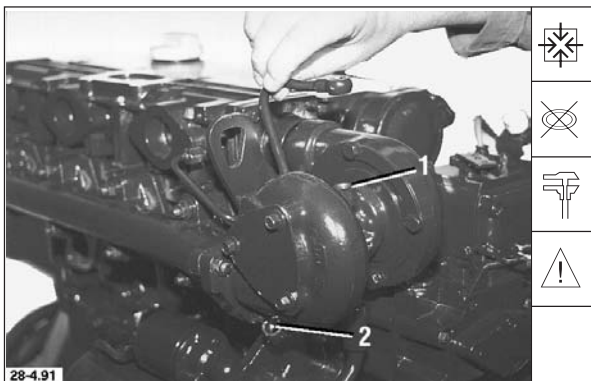
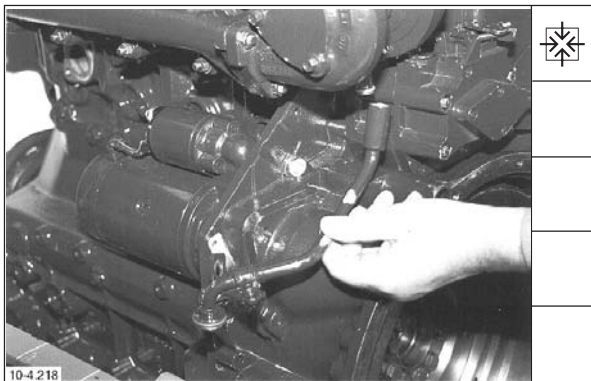
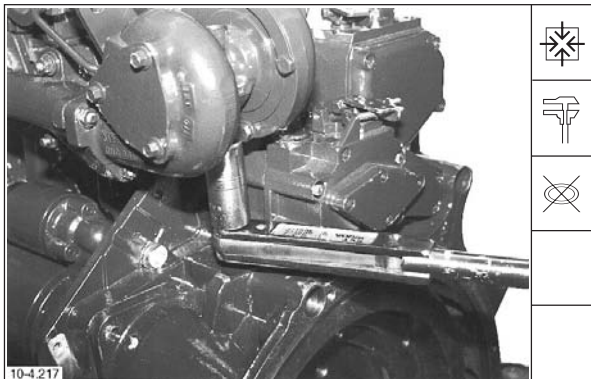

**Deutsch**

184. Einschraubstutzen mit neuem Cu-Dicht-  
ring und einem Drehmoment von  
**40 ± 2 Nm** festdrehen.

185. Ölrücklaufleitung anbauen. Halter fest-  
schrauben.

186. Druckölleitung anbauen:

Hohlschrauben mit neuen Cu-Dichtringen  
anbauen und mit einem Drehmoment von  
Pos. 1 **29 ± 3 Nm**  
Pos. 2 **39 ± 4 Nm**  
festdrehen.

**Hinweis:** Abgasturbolader durch einen  
Spritzer Öl in die Ölzulaufbohrung  
vorölen.

**Druckölleitung/Ölrücklaufrohr BFM 1013**

187. Druckölleitung mit neuer Dichtung  
anbauen.

**Hinweis:** Abgasturbolader durch einen  
Spritzer Öl in die Ölzulaufbohrung  
vorölen.

**Demontage und Montage, Motor komplett**  
**Disassembly and reassembly of complete engine**  
**Démontage et montage moteur complet**  
**Smontaggio e rimontaggio completo del motore**

English	Français	Italiano
184. Tighten screw plug with new Cu seal and a torque of <b>40 ± 2 Nm</b> .	184. Serrer la tubulure avec un joint d'étanchéité Cu neuf et au couple de <b>40 ± 2 Nm</b> .	184. Dopo averlo munito di un nuovo anello di tenuta in rame, serrare il manicotto filettato con una coppia di <b>40 ± 2 Nm</b> .
185. Mount oil return pipe. Tighten retainer.	185. Monter la conduite de retour d'huile et serrer le support.	185. Montare il tubo di ritorno dell'olio. Avvitare bene il supporto.
186. Mount pressure oil pipe:  Fit banjo bolts with new Cu seals and tighten with a torque of item 1 <b>29 ± 3 Nm</b> item 2 <b>39 ± 4 Nm</b> .	186. Monter la conduite de refoulement d'huile .  Serrer les vis creuses avec des joints d'étanchéité neufs et au couple de Pos. 1 <b>29 ± 3 Nm</b> Pos. 2 <b>39 ± 4 Nm</b> .	186. Montare la tubazione di mandata dell'olio:  montare le viti cave munite di nuovi anelli di tenuta in rame e serrarle con una coppia di pos. 1 <b>29 ± 3 Nm</b> pos. 2 <b>39 ± 4 Nm</b>
<b>Note:</b> Pre-lubricate turbocharger by spraying a drip of oil into the oil supply bore.	<b>Note:</b> huiler le turbocompresseur en injectant un peu d'huile dans l'alésage d'arrivée.	<b>Note:</b> Prelubrificare il turbocompressore spruzzando dell'olio nel foro d'entrata dell'olio.
<b>Pressure oil pipe/oil return pipe BFM 1013</b>	<b>Conduite de refoulement d'huile/ tuyau de retour d'huile BFM 1013</b>	<b>Tubazione di mandata dell'olio/Tubo di ritorno dell'olio BFM 1013</b>
187. Mount pressure oil pipe with new gasket.	187. Monter la conduite de refoulement d'huile avec un joint neuf.	187. Montare la tubazione di mandata dell'olio munita di una nuova guarnizione.
<b>Note:</b> Pre-lubricate turbocharger by spraying a drip of oil into the oil supply bore.	<b>Note:</b> huiler le turbocompresseur en injectant un peu d'huile dans l'alésage d'arrivée d'huile.	<b>Note:</b> Prelubrificare il turbocompressore spruzzando dell'olio nel foro d'entrata dell'olio.

**Demontage und Montage, Motor komplett**  
**Disassembly and reassembly of complete engine**  
**Démontage et montage moteur complet**  
**Smontaggio e rimontaggio completo del motore**

English	Français	Italiano
188. Tighten bolts with a torque of <b>21 ± 2 Nm.</b>	188. Serrer les vis au couple de <b>21 ± 2 Nm.</b>	188. Serrare le viti con una coppia di <b>21 ± 2 Nm.</b>
189. Fit banjo bolt with new Cu seals and tighten with a torque of <b>39 ± 3 Nm.</b>	189. Monter la vis creuse avec des joints d'étanchéité Cu neufs et serrer au couple de <b>39 ± 3 Nm.</b>	189. Montare la vite cava munita di nuovi anelli di tenuta in rame e serrarla con una coppia di <b>39 ± 3 Nm.</b>
190. Slide on new O-seals and apply dehydrated lubricant.	190. Monter les joints toriques neufs et les enduire d'un produit de montage anhydre.	190. Montare nuovi O-Ring e spalmarci un lubrificante per montaggi anidro.
191. Mount oil return pipe with new gasket.	191. Monter tube de retour avec joint neuf.	191. Montare il tubo di ritorno dell'olio munito di una nuova guarnizione.
<b>Note:</b> Apply dehydrated lubricant to receiving bore in crankcase.	<b>Nota:</b> enduire alésage de logement du bloc moteur d'un produit de montage anhydre.	<b>Nota:</b> Spalmare un lubrificante anidro per montaggi sul foro d'entrata nell'incastellatura del motore.



**Deutsch**

**Werkstatthandbuch BFM 1012/E, BFM 1013/E**

188. Schrauben mit einem Drehmoment von **21 ± 2 Nm** festdrehen.

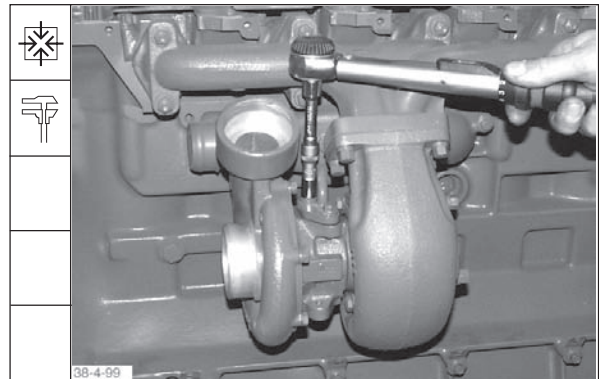

189. Hohl-schraube mit neuen Cu-Dichtringen anbauen und mit einem Drehmoment von **39 ± 3 Nm** festdrehen.

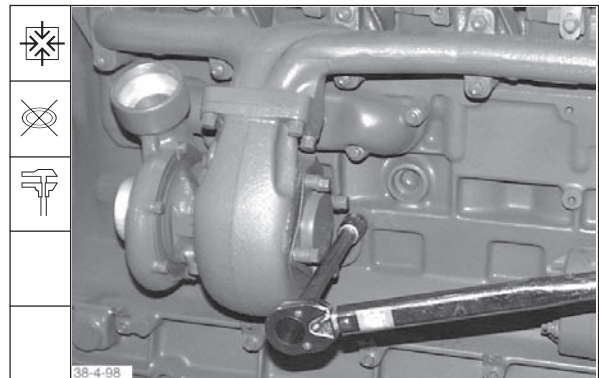

190. Neue Runddichtringe aufziehen und mit wasserfreiem Montage-mittel einstreichen.

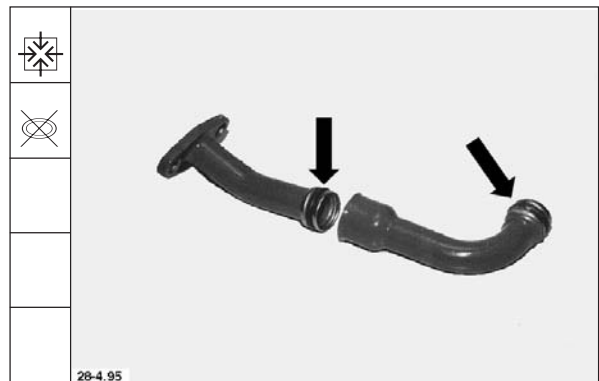

191. Rücklaufrohr mit neuer Dichtung anbauen.

**Hinweis:** Aufnahmebohrung im Kurbelgehäuse mit wasserfreiem Montage-mittel einstreichen.

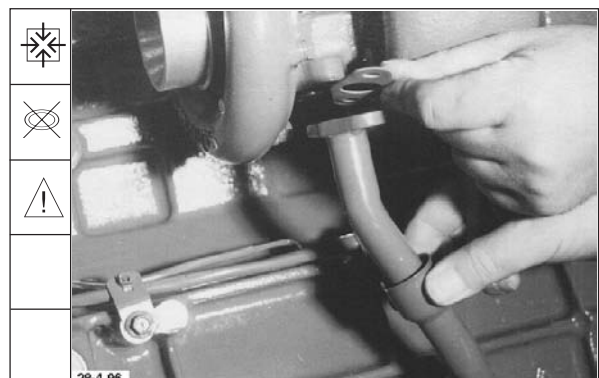

**Demontage und Montage, Motor komplett**  
**Disassembly and reassembly of complete engine**  
**Démontage et montage moteur complet**  
**Smontaggio e rimontaggio completo del motore**

Werkstatthandbuch BFM 1012/E, BFM 1013/E

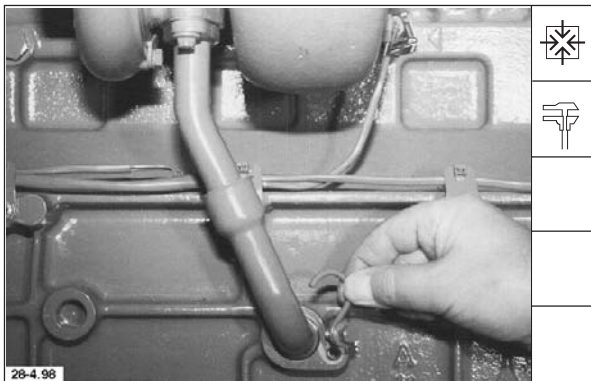
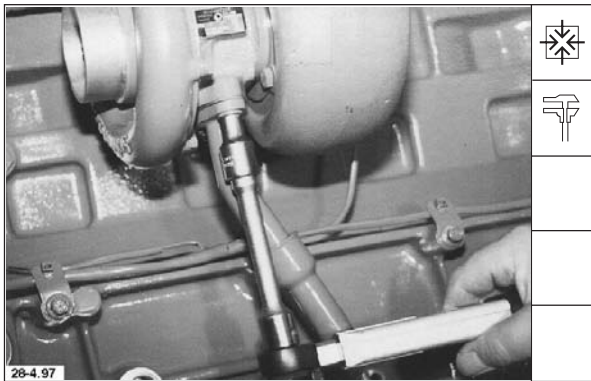

Deutsch

192. Schrauben mit einem Drehmoment von **21 ± 2 Nm** festdrehen.

193. Haltebügel anbauen. Schraube mit einem Drehmoment von **21 ± 2 Nm** festdrehen.

**Ansaugkrümmer BFM 1012**

194. Ansaugkrümmer (Schlauch) mit Schlauchschelle befestigen.

195. Winkelstutzen mit Schlauchschelle einsetzen.

**Hinweis:** Schlauchschelle noch nicht festdrehen.

**Demontage und Montage, Motor komplett**  
**Disassembly and reassembly of complete engine**  
**Démontage et montage moteur complet**  
**Smontaggio e rimontaggio completo del motore**

English	Français	Italiano
192. Tighten bolts with a torque of <b>21 ± 2 Nm</b> .	192. Serrer les vis au couple de <b>21 ± 2 Nm</b> .	192. Serrare le viti con una coppia di <b>21 ± 2 Nm</b> .
193. Fit clamping yoke. Tighten bolt with a torque of <b>21 ± 2 Nm</b> .	193. Monter l'étrier de fixation et serrer la vis au couple de <b>21 ± 2 Nm</b> .	193. Montare il cavalletto di supporto. Serrare la vite con una coppia di <b>21 ± 2 Nm</b> .
<b>Intake elbow BFM 1012</b>	<b>Tubulure d'aspiration BFM 1012</b>	<b>Curva di aspirazione BFM 1012</b>
194. Fasten intake elbow (hose) with hose clip.	194. Fixer la tubulure d'aspiration (flexible) à l'aide d'un collier.	194. Fissare la curva di aspirazione (flessibile) per mezzo di una fascetta
195. Insert elbow nipple with hose clip.	195. Placer le raccord en équerre avec le collier de serrage.	195. Montare il manicotto ad angolo con una fascetta.
<b>Note:</b> Do not tighten hose clip yet.	<b>Nota:</b> ne pas encore serrer le collier.	<b>Nota:</b> Attendere prima di serrare la fascetta.

**Demontage und Montage, Motor komplett**  
**Disassembly and reassembly of complete engine**  
**Démontage et montage moteur complet**  
**Smontaggio e rimontaggio completo del motore**

English	Français	Italiano
196. Mount breather hose and fasten. Tighten hose clip.	196. Monter flexible de purge et le fixer. Serrer collier de fixation.	196. Montare la tubazione di sfiato e fissarla. Serrare la fascetta.
<b>Intake elbow BFM 1013</b>	<b>Tubulure d'aspiration BFM 1013</b>	<b>Curva di aspirazione BFM 1013</b>
197. Mount intake elbow (hose).	197. Fixer la tubulure d'aspiration (flexible).	197. Montare la curva di aspirazione (flessibile)
<b>Note:</b> Do not tighten hose clip yet.	<b>Nota:</b> ne pas encore bloquer le collier de fixation.	<b>Nota:</b> Attendere prima di serrare la fascetta.
198. Mount breather pipe with retainer free of stress.	198. Monter conduite de purge avec support sans tension.	198. Montare senza forzarla la tubazione di sfiato col suo supporto.
199. Fit spring-loaded clamp.	199. Monter les colliers à ressort.	199. Montare i collarini elastici.
<b>Note:</b> Use spring clamp pliers.	<b>Nota:</b> utiliser la pince à crampon élastique.	<b>Nota:</b> Servirsi dell'apposita pinza.

**Deutsch**

**Werkstatthandbuch BFM 1012/E, BFM 1013/E**

196. Entlüftungsschlauch montieren und befestigen. Schlauchschelle festdrehen.



**Ansaugkrümmer BFM 1013**

197. Ansaugkrümmer (Schlauch) anbauen.

**Hinweis:** Schlauchschelle noch nicht festdrehen.

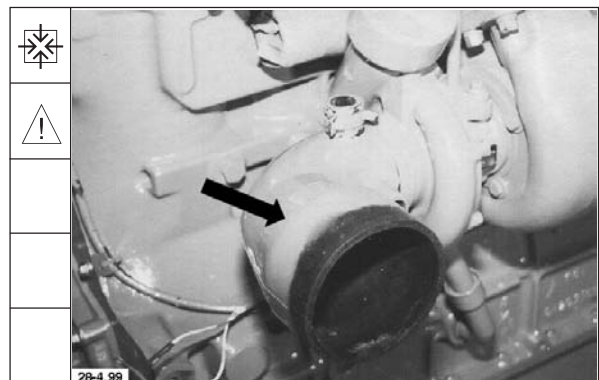

198. Entlüftungsleitung mit Halter spannungsfrei anbauen.



199. Federklemmen montieren.

**Hinweis:** Federklemmenzange benutzen.

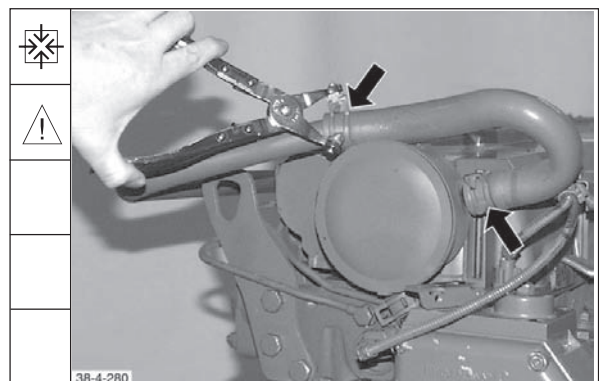

**Demontage und Montage, Motor komplett**  
**Disassembly and reassembly of complete engine**  
**Démontage et montage moteur complet**  
**Smontaggio e rimontaggio completo del motore**

Werkstatthandbuch BFM 1012/E, BFM 1013/E

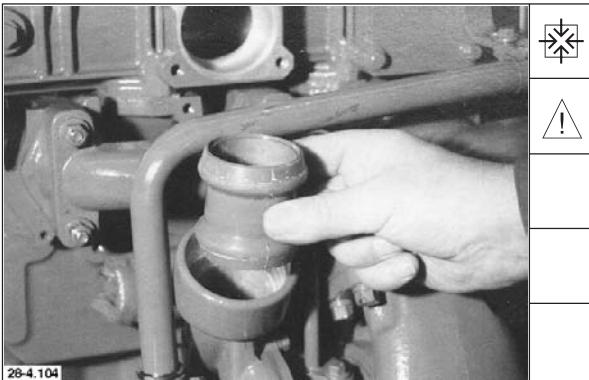
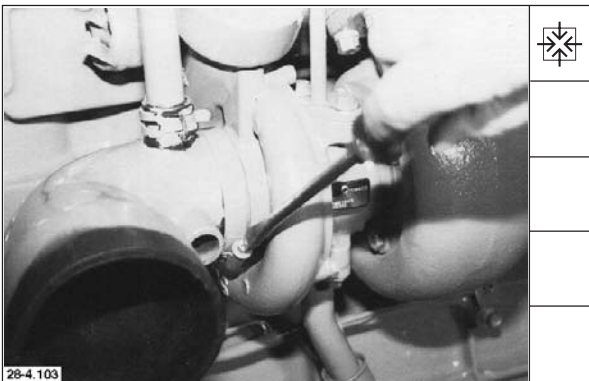
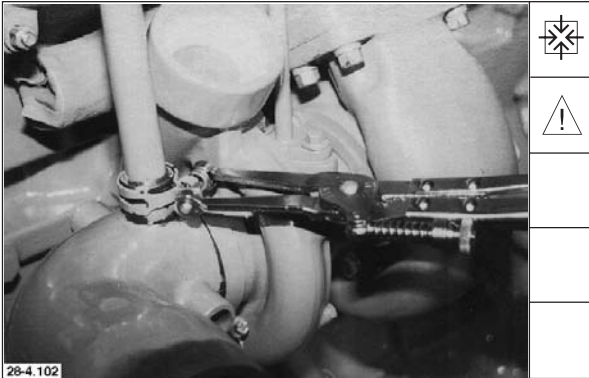

**Deutsch**

200. Federklemme montieren.

**Hinweis:** Federklemmenzange benutzen.

201. Schlauchschelle festdrehen.

**Ladeluftkrümmer BFM 1013**

202. Steckstück eindrücken.

**Hinweis:** Dichtprofil und Aufnahmebohrung mit Montagemittel einstreichen.

203. Ladeluftkrümmer mit neuer Dichtung anbauen.

**Demontage und Montage, Motor komplett**  
**Disassembly and reassembly of complete engine**  
**Démontage et montage moteur complet**  
**Smontaggio e rimontaggio completo del motore**

English	Français	Italiano
<p>200. Fit spring-loaded clamp.</p> <p><b>Note:</b> Use spring clamp pliers.</p>	<p>200. Monter crampon à ressort.</p> <p><b>Nota:</b> utiliser la pince à crampon à ressort.</p>	<p>200. Montare i collarini elastici.</p> <p><b>Nota:</b> Servirsi dell'apposita pinza.</p>
<p>201. Secure hose clip.</p>	<p>201. Serrer le collier de fixation.</p>	<p>201. Serrare la fascetta.</p>
<p><b>Charge air elbow BFM 1013</b></p>	<p><b>Conduite d'air de suralimentation BFM 1013</b></p>	<p><b>Curva per l'aria di sovralimentazione BFM 1013</b></p>
<p>202. Press in plug-in element.</p> <p><b>Note:</b> Apply lubricant to sealing section and receiving bore.</p>	<p>202. Introduire le manchon.</p> <p><b>Nota:</b> enduire d'un produit de montage le profilé d'étanchéité et l'alésage du logement.</p>	<p>202. Inserire il connettore ad innesto</p> <p><b>Nota:</b> Umettare il profilo di tenuta ed il foro d'alloggiamento con un lubrificante per montaggi.</p>
<p>203. Mount charge air elbow with new seal.</p>	<p>203. Monter la conduite d'air de suralimentation avec un joint neuf.</p>	<p>203. Montare la curva dell'aria di sovralimentazione con una nuova guarnizione.</p>

**Demontage und Montage, Motor komplett**  
**Disassembly and reassembly of complete engine**  
**Démontage et montage moteur complet**  
**Smontaggio e rimontaggio completo del motore**

English	Français	Italiano
204. Tighten bolts with a torque of <b>22 ± 2 Nm.</b>	204. Serrer les vis au couple de <b>22 ± 2 Nm.</b>	204. Serrare le viti con una coppia di <b>22 ± 2 Nm.</b>
205. Fit oil filler neck, if any, complete with new seal and tighten with a torque of <b>21 ± 2 Nm.</b>	205. Selon l'équipement du moteur serrer la tubulure de remplissage d'huile au couple de <b>21 ± 2 Nm</b> en utilisant un joint neuf.	205. Qualora ci sia, montare il bocchettone di rabbocco dell'olio munito di nuova guarnizione e serrarlo con una coppia di <b>21 ± 2 Nm.</b>
<b>Oil dipstick</b>	<b>Jauge d'huile</b>	<b>Astina di livello dell'olio</b>
206. Slide on new O-seal.	206. Monter un joint torique neuf.	206. Infilarsi un nuovo O-ring.
207. Press in oil dipstick as far as it will go.	207. Insérer la jauge d'huile jusqu'en position d'appui.	207. Infilare l'astina di livello e spingerla fino a battuta.



Deutsch

Werkstatthandbuch BFM 1012/E, BFM 1013/E

204. Schrauben mit einem Drehmoment von  $22 \pm 2$  Nm festdrehen.



205. Falls vorhanden, Öleinfüllstutzen mit neuer Dichtung anbauen und mit einem Drehmoment von  $21 \pm 2$  Nm festdrehen.

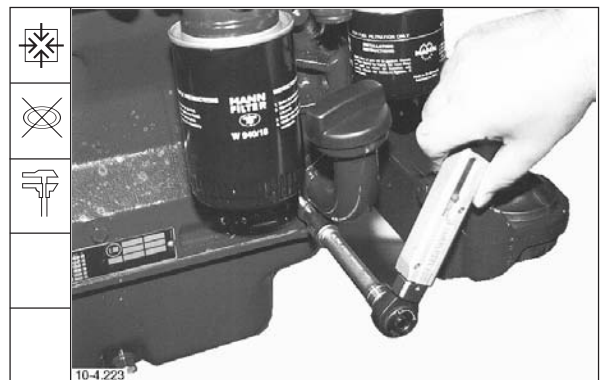

Ölmeßstab

206. Neuen Runddichtring aufziehen.

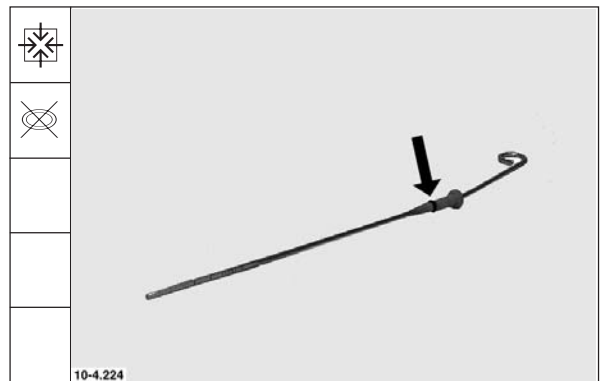

207. Ölmeßstab bis Anlage eindrücken.



**Demontage und Montage, Motor komplett**  
**Disassembly and reassembly of complete engine**  
**Démontage et montage moteur complet**  
**Smontaggio e rimontaggio completo del motore**

Werkstatthandbuch BFM 1012/E, BFM 1013/E

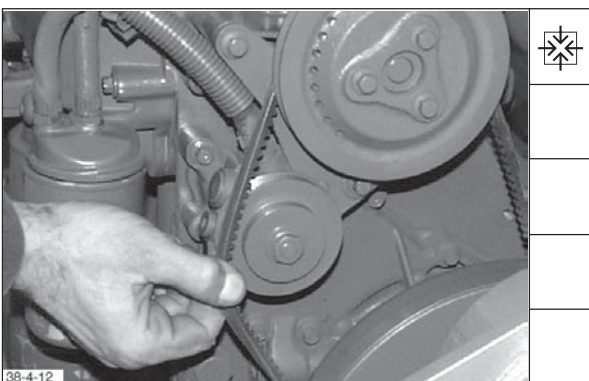
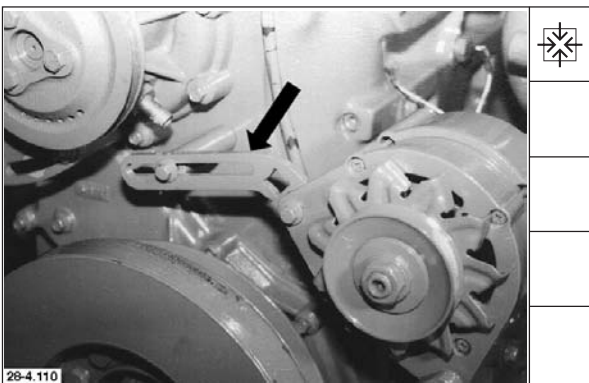
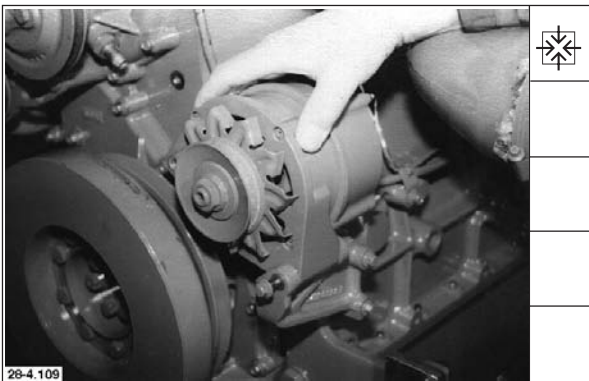
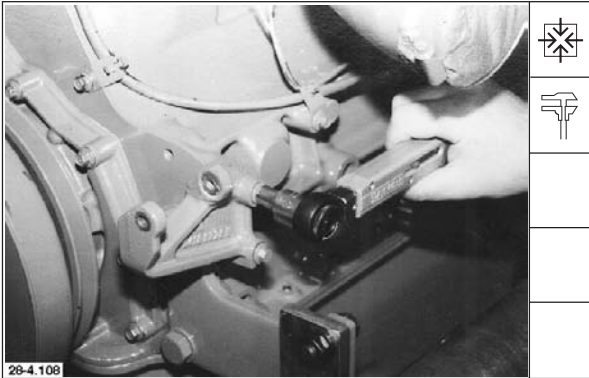

Deutsch

**Generator**

208. Konsole anbauen. Schrauben mit einem Drehmoment von **21 ± 2 Nm** festdrehen.

209. Generator anbauen. Sechskantschraube leicht andrehen.

210. Spannlasche mit Abstandsbuchsen anbauen. Sechskantschrauben leicht andrehen.

**Keilriemen spannen**

211. Keilriemen auflegen.

**Demontage und Montage, Motor komplett**  
**Disassembly and reassembly of complete engine**  
**Démontage et montage moteur complet**  
**Smontaggio e rimontaggio completo del motore**

English	Français	Italiano
<b>Alternator</b>	<b>Alternateur</b>	<b>Generatore</b>
208. Fit alternator bracket. Tighten bolts with a torque of <b>21 ± 2 Nm.</b>	208. Monter la console et serrer les vis au couple de <b>21 ± 2 Nm.</b>	208. Montare la mensola. Serrare e serrare le viti con una coppia di <b>21 ± 2 Nm.</b>
209. Mount alternator. Start hex. bolt.	209. Monter l'alternateur. Serrer modérément la vis six pans.	209. Montare il generatore. Avvitare a mano la vite a testa esagonale.
210. Fit clamping plate together with spacer bushes. Start hex. bolts.	210. Monter la griffe de serrage avec des douilles d'écartement. Serrer légèrement les vis six pans.	210. Montare la staffa di regolazione della tensione della cinghia assieme alle boccole distanziatrici. avvitare a mano le viti a testa esagonale.
<b>Tensioning V-belt</b>	<b>Tendre la courroie trapézoïdale</b>	<b>Regolazione della tensione della cinghia trapezoidale.</b>
211. Position V-belt.	211. Monter la courroie trapézoïdale.	211. Montare la cinghia trapezoidale.

**Demontage und Montage, Motor komplett**  
**Disassembly and reassembly of complete engine**  
**Démontage et montage moteur complet**  
**Smontaggio e rimontaggio completo del motore**

English	Français	Italiano
<p>212. Tension V-belt. Tighten bolts with a torque of <b>21 ± 2 Nm</b>.</p>	<p>212. Tendre la courroie trapézoïdale et serrer les vis au couple de <b>21 ± 2 Nm</b>.</p>	<p>212. Tendere la cinghia trapezoidale. Serrare le viti con una coppia di <b>21 ± 2 Nm</b>.</p>
<p>213. Check V-belt tension with belt tension gauge.</p> <p>Belt back width 10 mm            Initial assembly ____ <b>450 ± 50 N</b>            Check value after 15 min.of operation under load <b>300 ± 50 N</b>            When reusing belt ____ <b>300 ± 50 N</b></p> <p>Belt back width 13 mm            Initial assembly ____ <b>550 ± 50 N</b>            Check value after 15 min.of operation under load <b>400 ± 50 N</b>            When reusing belt ____ <b>400 ± 50 N</b></p>	<p>213. Contrôler la tension de la courroie trapézoïdale à l'aide d'un tensiomètre.</p> <p>Largeur du dos de la courroie 10 mm            Première monte ____ <b>450 ± 50 N</b>            Contrôle après 15 min de marche Sous charge ____ <b>300 ± 50 N</b>            Après réutilisation ____ <b>300 ± 50 N</b></p> <p>Largeur du dos de la courroie 13 mm            Première monte ____ <b>550 ± 50 N</b>            Contrôle après 15 min de marche Sous charge ____ <b>400 ± 50 N</b>            Après réutilisation ____ <b>400 ± 50 N</b></p>	<p>213. Controllare la tensione della cinghia trapezoidale per mezzo dell'apposito strumento di misura.</p> <p>Cinghia con dorso di 10 mm            Primo montaggio ____ <b>450 ± 50 N</b>            Controllo dopo 15 minuti di funzion. sotto carico _ <b>300 ± 50 N</b>            Quando si riutilizza _ <b>300 ± 50 N</b></p> <p>Cinghia con dorso di 13 mm            Primo montaggio ____ <b>550 ± 50 N</b>            Controllo dopo 15 minuti di funzion. sotto carico _ <b>400 ± 50 N</b>            Quando si riutilizza _ <b>400 ± 50 N</b></p>
<p>214. Position V-belt.</p>	<p>214. Monter la courroie.</p>	<p>214. Montare la cinghia trapezoidale.</p>
<p>215. Tension V-belt. Tighten bolts with a torque of <b>30 Nm</b>.</p>	<p>215. Tendre la courroie trapézoïdale et serrer les vis au couple de <b>30 Nm</b>.</p>	<p>215. Tendere la cinghia trapezoidale. Serrare le viti con una coppia di <b>30 Nm</b>.</p>

**Deutsch**

**Werkstatthandbuch BFM 1012/E, BFM 1013/E**

212. Keilriemen spannen. Schrauben mit einem Drehmoment von **21 ± 2 Nm** festdrehen.

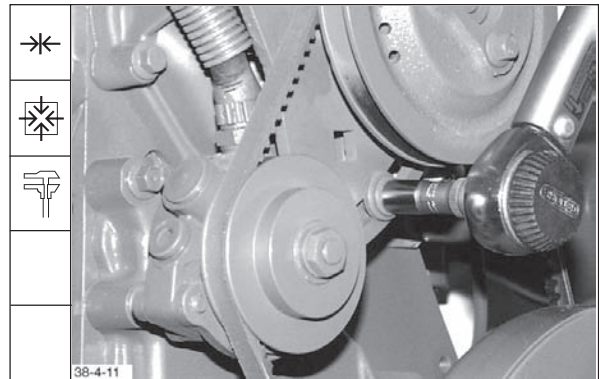

213. Keilriemenspannung mit einem Spannungsmeßgerät prüfen.

Riemenrückenbreite 10 mm  
 Erstmontage \_\_\_\_\_ **450 ± 50 N**  
 Kontrolle nach 15 Min. Lauf  
 unter Last \_\_\_\_\_ **300 ± 50 N**  
 Bei Wiederverwendung \_\_\_\_\_ **300 ± 50 N**

Riemenrückenbreite 13 mm  
 Erstmontage \_\_\_\_\_ **550 ± 50 N**  
 Kontrolle nach 15 Min. Lauf  
 unter Last \_\_\_\_\_ **400 ± 50 N**  
 Bei Wiederverwendung \_\_\_\_\_ **400 ± 50 N**

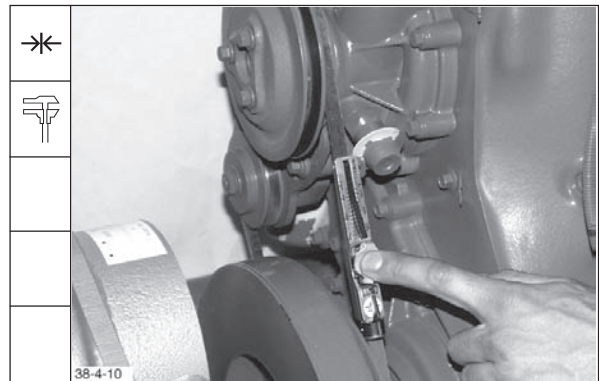

214. Keilriemen auflegen.

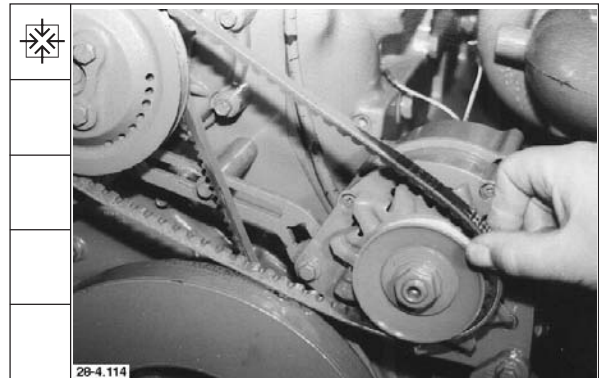

215. Keilriemen spannen. Schrauben mit einem Drehmoment von **30 Nm** festdrehen.

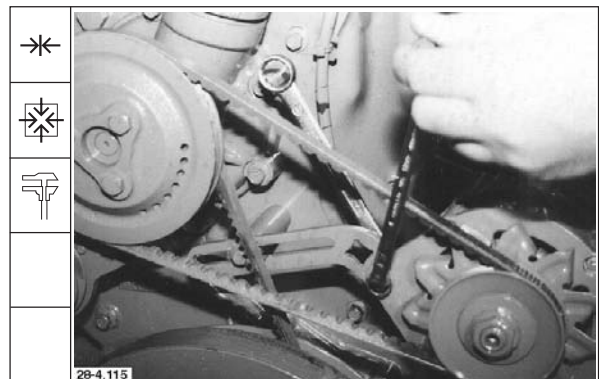

**Demontage und Montage, Motor komplett**  
**Disassembly and reassembly of complete engine**  
**Démontage et montage moteur complet**  
**Smontaggio e rimontaggio completo del motore**

**Werkstatthandbuch BFM 1012/E, BFM 1013/E**

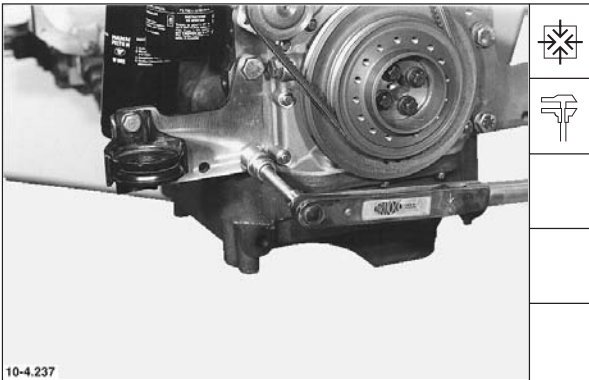
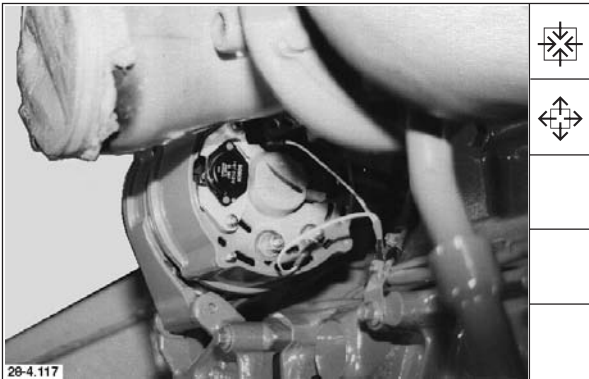
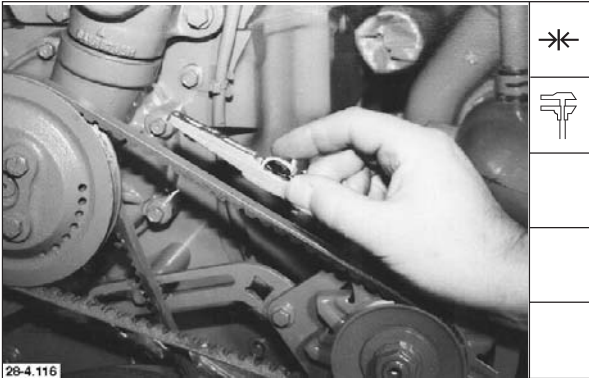

**Deutsch**

216. Keilriemenspannung mit einem Spannungsmeßgerät prüfen.

Erstmontage \_\_\_\_\_ **450 ± 50 N**  
 Kontrolle nach 15 Min. Lauf  
 unter Last \_\_\_\_\_ **300 ± 50 N**  
 Bei Wiederverwendung \_\_\_\_\_ **300 ± 50 N**

217. Nach dem Riemenspannen sind die übrigen Schrauben festzudrehen und die Kabel anzuklemmen.

Motor von Montagebock abbauen.

**Motoraufhängung/Aufstellfüße**

218. Motoraufhängung anbauen. Schrauben mit einem Drehmoment von **260 Nm** festdrehen.

219. Aufstellfüße anbauen. Schrauben mit einem Drehmoment von **95 Nm** festdrehen.



**Demontage und Montage, Motor komplett**  
**Disassembly and reassembly of complete engine**  
**Démontage et montage moteur complet**  
**Smontaggio e rimontaggio completo del motore**

English	Français	Italiano
<p>216. Check V-belt tension with belt tension gauge.</p> <p>Initial assembly <b>450 ± 50 N</b>            Check value after 15 min. of operation under load <b>300 ± 50 N</b>            When reusing belt <b>300 ± 50 N</b></p>	<p>216. Vérifier la tension de courroie avec un appareil de mesure.</p> <p>Première monte <b>450 ± 50 N</b>            Contrôle après une marche de 15 min sous charge <b>300 ± 50 N</b>            Pour réutilisation <b>300 ± 50 N</b></p>	<p>216. Controllare la tensione della cinghia trapezoidale per mezzo dell'apposito attrezzo di misura. Primo montaggio <b>450 ± 50 N</b>            Controllo dopo 15 minuti di funzion. sotto carico <b>300 ± 50 N</b>            Quando si riutilizza <b>300 ± 50 N</b></p>
<p>217. After tensioning of belt tighten remaining bolts and connect cables.</p> <p>Remove engine from assembly stand.</p>	<p>217. Après avoir tendu la courroie serrer les autres vis et brancher les câbles.</p> <p>Déposer le moteur du chevalet de montage.</p>	<p>217. Dopo aver teso la cinghia si devono serrare le restanti viti e connettere i cavi.</p> <p>Smontare il motore dal cavalletto orientabile.</p>
<p><b>Engine mounting/mounting feet</b></p>	<p><b>Suspension moteur/pieds</b></p>	<p><b>Sospensioni del motore/Piedini di appoggio</b></p>
<p>218. Fit engine mounting. Tighten bolts with a torque of <b>260 Nm</b>.</p>	<p>218. Monter la suspension du moteur. Serrer les vis au couple de serrage de <b>260 Nm</b>.</p>	<p>218. Montare le sospensioni del motore. Serrare le viti con una coppia di <b>260 Nm</b>.</p>
<p>219. Fit mounting feet. Tighten bolts with a torque of <b>95 Nm</b>.</p>	<p>219. Monter les pieds du moteur. Serrer les vis au couple de <b>95 Nm</b>.</p>	<p>219. Montare i piedini di appoggio. Serrare le viti con una coppia di <b>95 Nm</b>.</p>

**Demontage und Montage, Motor komplett**  
**Disassembly and reassembly of complete engine**  
**Démontage et montage moteur complet**  
**Smontaggio e rimontaggio completo del motore**

English	Français	Italiano
<p><b>Removing and refitting components for integrated cooling system - BFM 1012</b></p> <p>The components may differ from the illustrations shown here, depending on the engine scope of supply.</p> <p>Drain and catch coolant and oil.</p>	<p><b>Montage et démontage des éléments du refroidissement intégré du - BFM 1012</b></p> <p>Selon le volume de livraison du moteur les pièces auxiliaires peuvent être différentes des croquis.</p> <p>Vidanger et récupérer le liquide de refroidissement usagé ou l'huile usée.</p>	<p><b>Montaggio e smontaggio dei componenti del sistema di raffreddamento integrato - BFM 1012</b></p> <p>A seconda dell'entità di fornitura del motore, qualche componente può essere diverso da quelli illustrati.</p> <p>Scaricare completamente liquido refrigerante ed olio e raccogliarli in recipienti adatti.</p>
<p><b>Removing components</b></p> <ol style="list-style-type: none"><li>1. Loosen tension pulley, take off V-belt.</li><li>2. Remove tension pulley together with bracket.</li><li>3. Remove air guide ring.</li></ol>	<p><b>Dépose des composants</b></p> <ol style="list-style-type: none"><li>1. Desserrer le galet tendeur et retirer la courroie.</li><li>2. Déposer la galet tendeur et la console.</li><li>3. Déposer le diffuseur d'air.</li></ol>	<p><b>Smontaggio dei componenti</b></p> <ol style="list-style-type: none"><li>1. Allentare il rullo tendicinghia e smontare la cinghia trapezoidale.</li><li>2. Smontare il rullo tendicinghia assieme alla mensola.</li><li>3. Smontare l'imbuto per l'aria.</li></ol>



**Deutsch**

**Werkstatthandbuch BFM 1012/E, BFM 1013/E**

**Bauteile für integrierte Kühlung ab- und anbauen - BFM 1012**

Je nach Lieferumfang des Motors können die Anbauteile von den gezeigten Abbildungen abweichen.

Kühlflüssigkeit bzw. Öl ablassen und auffangen.

**Bauteile abbauen**

1. Spannrolle lösen, Keilriemen abnehmen.

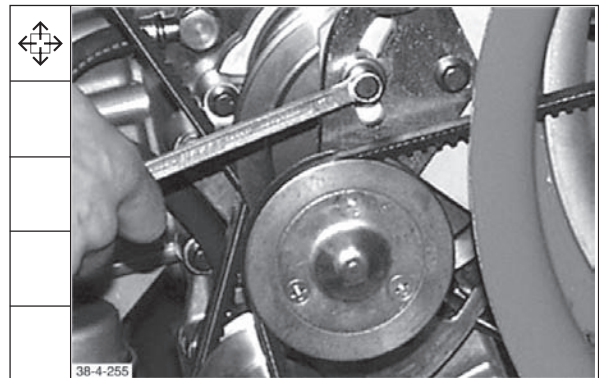

2. Spannrolle mit Konsole abbauen.

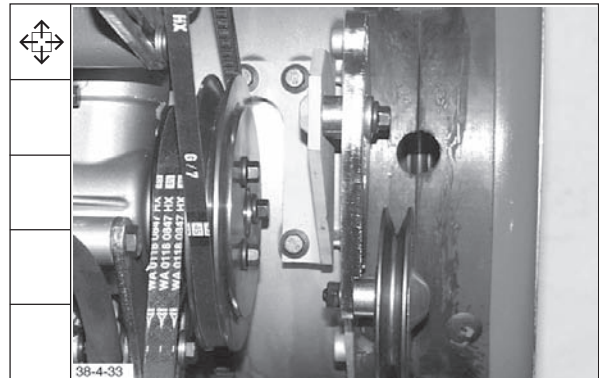

3. Lufttrichter abbauen.

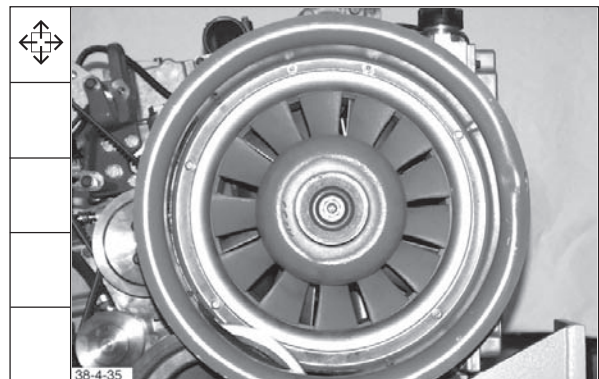

# Demontage und Montage, Motor komplett Disassembly and reassembly of complete engine Démontage et montage moteur complet Smontaggio e rimontaggio completo del motore

Werkstatthandbuch BFM 1012/E, BFM 1013/E

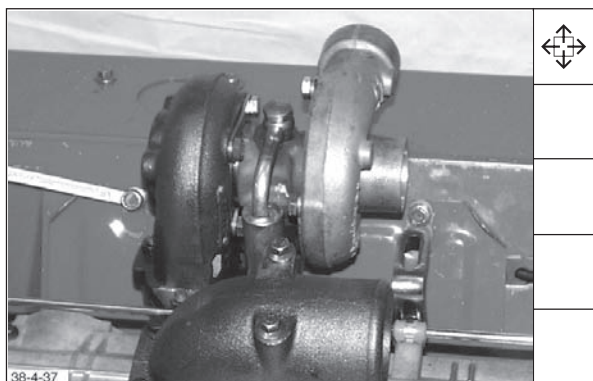
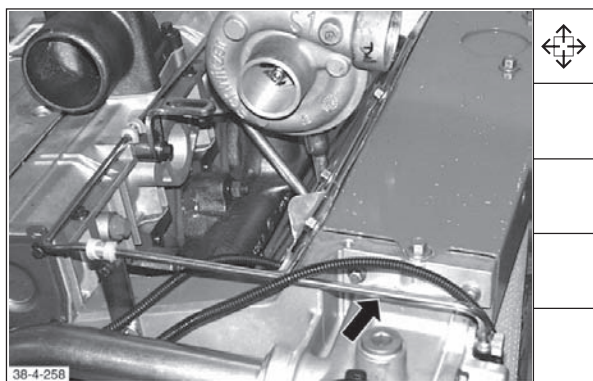
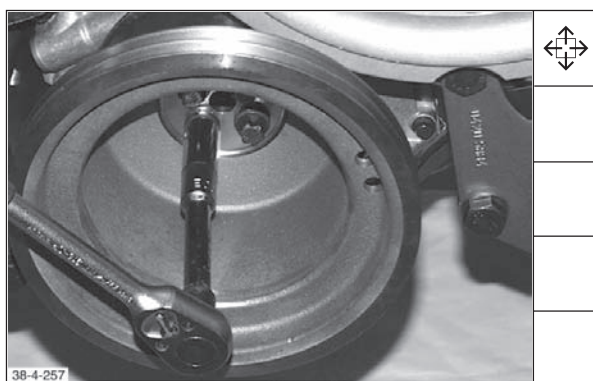
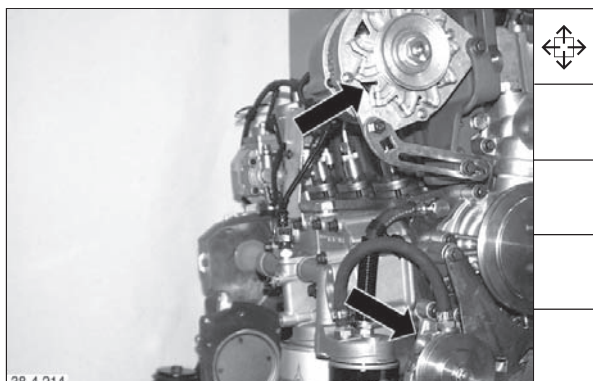

## Deutsch

4. Generator und Kraftstoffpumpe lösen. Keilriemen abnehmen. Generator und Kraftstoffpumpe abbauen.
  
5. Keilriemenscheibe am Schwungrad gegenhalten. Keilriemenscheibe und Schwingungsdämpfer abbauen.
  
6. Entlüftungsleitung abbauen.
  
7. Schaulochblech abbauen.

**Demontage und Montage, Motor komplett**  
**Disassembly and reassembly of complete engine**  
**Démontage et montage moteur complet**  
**Smontaggio e rimontaggio completo del motore**

English	Français	Italiano
4. Loosen alternator and fuel pump, take of V-belt. Remove alternator and fuel pump.	4. Desserrer l'alternateur et la pompe de combustible. Retirer la courroie trapézoïdale. Déposer l'alternateur et la pompe de combustible.	4. Allentare i fissaggi del generatore e della pompa del combustibile. Smontare la cinghia trapezoidale. Smontare il generatore e la pompa del combustibile
5. Retain V-belt pulley against flywheel. Remove V-belt pulley and vibration damper.	5. Maintenir la poulie à gorge du volant moteur. Déposer la poulie et l'amortisseur de vibrations.	5. Tenere fermo il volano con la cinghia trapezoidale. Smontare la puleggia della cinghia trapezoidale e lo smorzatore delle vibrazioni torsionali.
6. Remove breather pipe.	6. Déposer la conduite de purge.	6. Smontare la tubazione di sfiato.
7. Remove inspection hole plate.	7. Déposer la tôle à trou de regard.	7. Smontare la lamiera col foro di controllo.

**Demontage und Montage, Motor komplett**  
**Disassembly and reassembly of complete engine**  
**Démontage et montage moteur complet**  
**Smontaggio e rimontaggio completo del motore**

English	Français	Italiano
8. Remove top cover plate.	8. Déposer la tôle de recouvrement supérieure.	8. Smontare la lamiera di protezione superiore.
9. Remove central cover plate.	9. Déposer la tôle de recouvrement du milieu.	9. Smontare la lamiera di protezione mediana.
10. Remove bottom cover plate.	10. Déposer la tôle de recouvrement inférieure.	10. Smontare la lamiera di protezione inferiore.
11. Remove retainer from radiator.	11. Déposer le support du refoidisseur à liquide.	11. Smontare il supporto del radiatore del liquido refrigerante.

**Deutsch**

**Werkstatthandbuch BFM 1012/E, BFM 1013/E**

8. Abdeckblech oben abbauen.

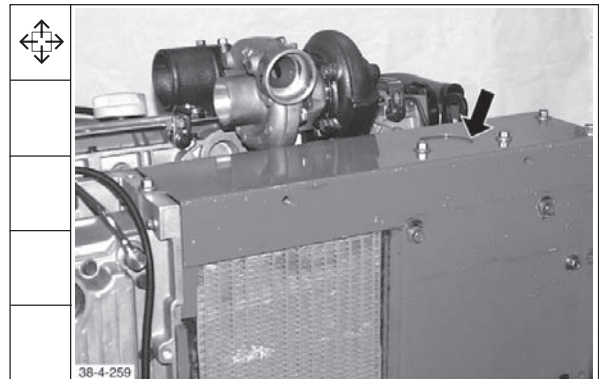

9. Abdeckblech mitte abbauen.

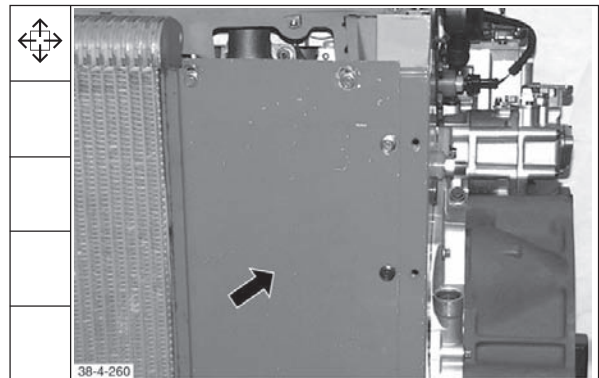

10. Abdeckblech unten abbauen.

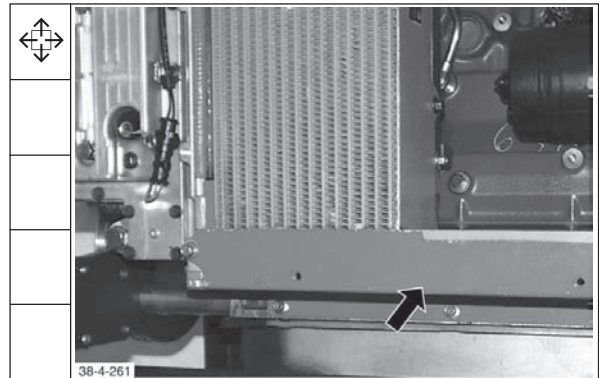

11. Halter vom Flüssigkeitskühler abbauen.

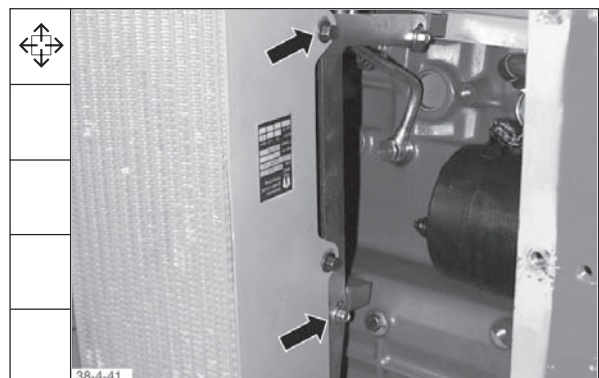



**Demontage und Montage, Motor komplett**  
**Disassembly and reassembly of complete engine**  
**Démontage et montage moteur complet**  
**Smontaggio e rimontaggio completo del motore**

**Werkstatthandbuch BFM 1012/E, BFM 1013/E**

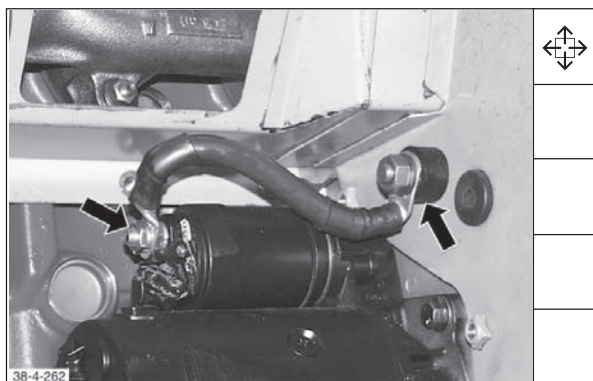
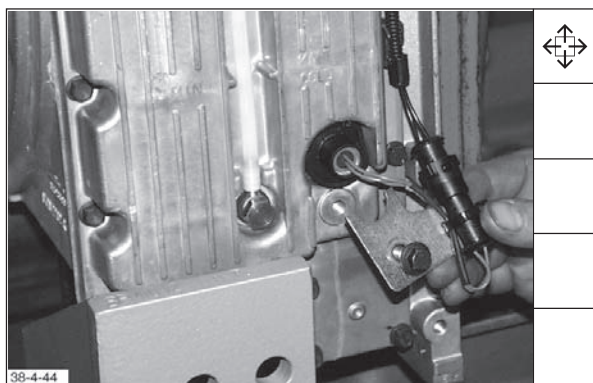
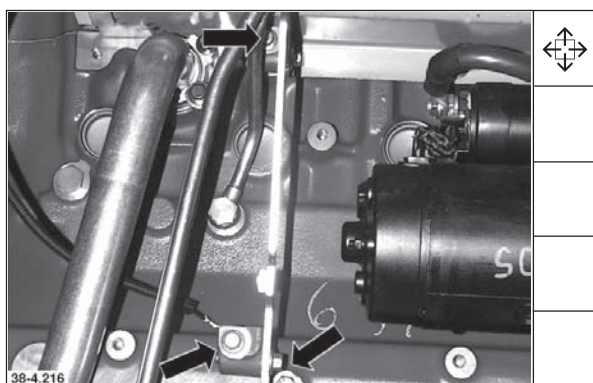
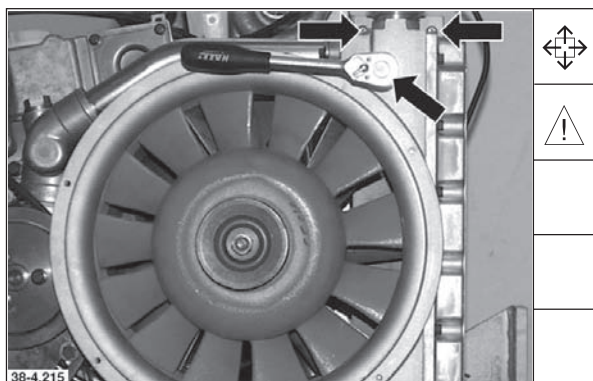

**Deutsch**

12. Flüssigkeitskühler abbauen.

**Hinweis:** Auslaufendes Restkühlmittel auffangen.

13. Halter abbauen.

14. Verkabelung Niveauschalter Kühlmittel abbauen.

15. Kabel von Starter und Anschlussbolzen abbauen.

**Demontage und Montage, Motor komplett**  
**Disassembly and reassembly of complete engine**  
**Démontage et montage moteur complet**  
**Smontaggio e rimontaggio completo del motore**

English	Français	Italiano
<p>12. Remove radiator.</p> <p><b>Note:</b> Catch any escaping coolant that has remained in the radiator.</p>	<p>12. Déposer le radiateur.</p> <p><b>Nota:</b> récupérer le réfrigérant qui s'écoule.</p>	<p>12. Smontare il radiatore di raffreddamento del liquido refrigerante.</p> <p><b>Nota:</b> Raccogliere il resto di liquido refrigerante che cola fuori.</p>
<p>13. Remove retainer.</p>	<p>13. Déposer le support.</p>	<p>13. Smontare il supporto.</p>
<p>14. Remove cabling from coolant level switch.</p>	<p>14. Déposer le câblage d'interrupteur du niveau du réfrigérateur.</p>	<p>14. Smontare il cablaggio del sensore del livello del liquido refrigerante.</p>
<p>15. Remove cables from starter and terminal stud.</p>	<p>15. Déposer le câble du démarreur et le boulon de fixation.</p>	<p>15. Smontare il cavo tra il motorino d'avviamento ed il bullone di collegamento.</p>

**Demontage und Montage, Motor komplett**  
**Disassembly and reassembly of complete engine**  
**Démontage et montage moteur complet**  
**Smontaggio e rimontaggio completo del motore**

English	Français	Italiano
16. Remove cover plate.	16. Déposer la tôle d'extrémité.	16. Smontare la lamiera di chiusura.
17. Remove oil pressure pipe.	17. Déposer la conduite de refoulement d'huile.	17. Smontare la tubazione di mandata dell'olio.
18. Remove oil return pipe.	18. Déposer le tuyau de retour d'huile.	18. Smontare la tubazione di ritorno dell'olio
19. Remove cover plate.	19. Déposer la tôle de recouvrement.	19. Smontare la lamiera di copertura.



**Deutsch**

**Werkstatthandbuch BFM 1012/E, BFM 1013/E**

16. Abschlußblech abbauen.

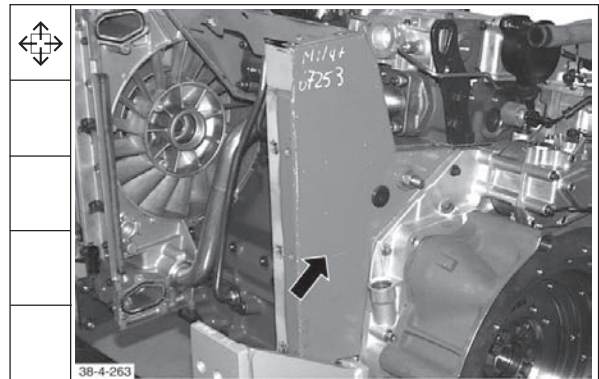

17. Öldruckleitung abbauen.

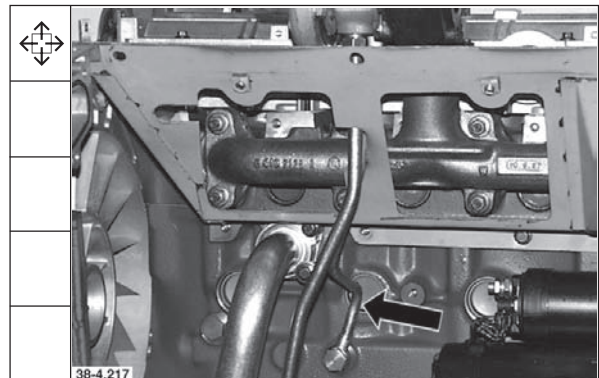

18. Ölrücklaufrohr abbauen.

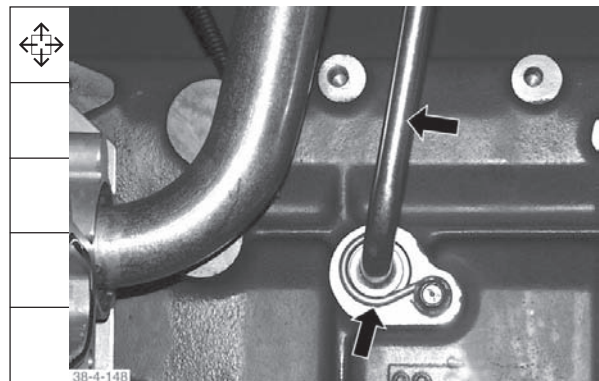

19. Abdeckblech abbauen.

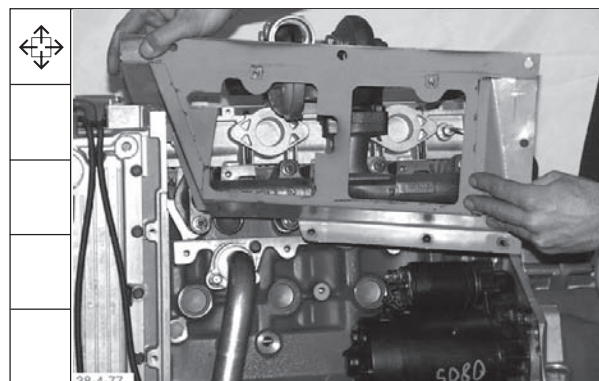

**Demontage und Montage, Motor komplett**  
**Disassembly and reassembly of complete engine**  
**Démontage et montage moteur complet**  
**Smontaggio e rimontaggio completo del motore**

Werkstatthandbuch BFM 1012/E, BFM 1013/E

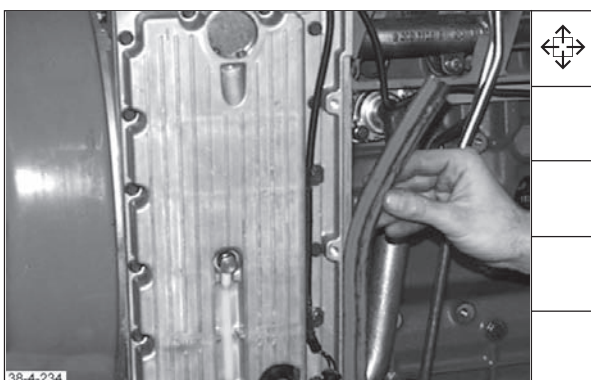
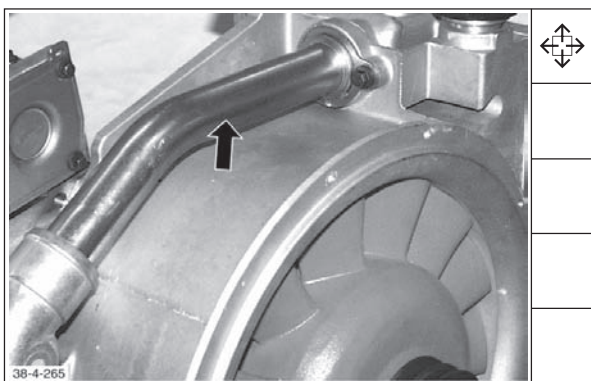
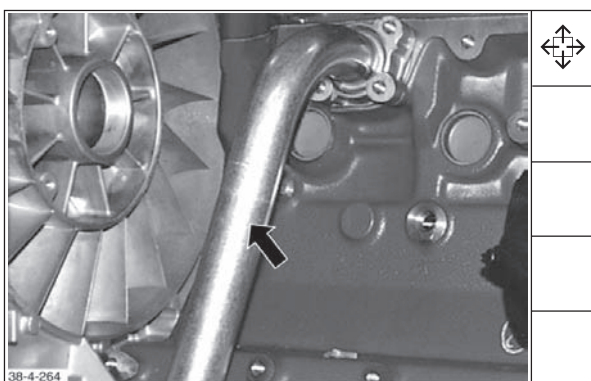
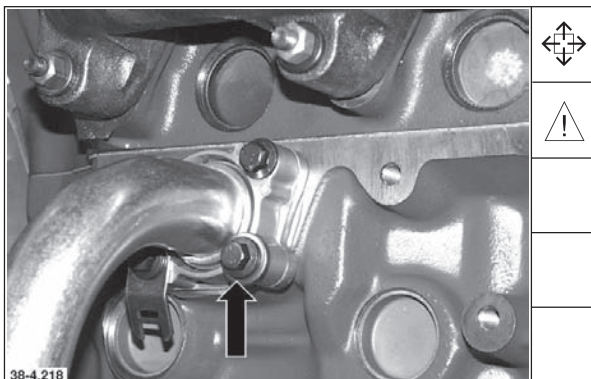

**Deutsch**

20. Schrauben für Flansch heraus-schrauben.

**Hinweis:** Auf Position der Sicherungsscheibe achten.

21. Kühlmittleitung abbauen.

22. Kühlmittleitung abbauen.

23. Klemmprofil abnehmen.

**Demontage und Montage, Motor komplett**  
**Disassembly and reassembly of complete engine**  
**Démontage et montage moteur complet**  
**Smontaggio e rimontaggio completo del motore**

English	Français	Italiano
20. Unscrew bolts for flange.  <b>Note:</b> Pay attention to position of locking washer.	20. Dévisser et retirer les vis de la bride.  <b>Nota:</b> veiller au bon positionnement de la rondelle d'arrêt.	20. Svitare e togliere le viti della flangia.  <b>Nota:</b> Tenere presente la posizione della rondella di sicurezza.
21. Remove coolant pipe.	21. Déposer la conduite de réfrigérant.	21. Smontare la tubazione del liquido refrigerante.
22. Remove coolant pipe.	22. Déposer la conduite de réfrigérant.	22. Smontare la tubazione del liquido refrigerante.
23. Take off clamping section.	23. Retirer le profilé de serrage.	23. Smontare il profilo di gomma.

**Demontage und Montage, Motor komplett**  
**Disassembly and reassembly of complete engine**  
**Démontage et montage moteur complet**  
**Smontaggio e rimontaggio completo del motore**

English	Français	Italiano
24. Remove coolant compensating pipe.	24. Déposer la conduite de compensation de réfrigérant.	24. Smontare la tubazione di compenso del liquido refrigerante.
25. Remove complete blower.  <b>Note:</b> Catch any escaping coolant.	25. Déposer entièrement la soufflante de refroidissement.  <b>Nota:</b> récupérer le réfrigérant qui s'écoule.	25. Smontare la soffiante di raffreddamento completa.  <b>Nota:</b> Raccogliere il liquido refrigerante che cola fuori.
26. Detach cable connections.	26. Désolidariser les connexions des câbles.	26. Staccare i cavi di collegamento.
27. Remove cable harness.	27. Déposer le faisceau des câbles.	27. Smontare il fascio di cavi.

Deutsch

Werkstatthandbuch BFM 1012/E, BFM 1013/E

24. Kühlmittel-Ausgleichsleitung abbauen.



25. Kühlgebläse komplett abbauen.

**Hinweis:** Auslaufendes Kühlmittel auffangen.

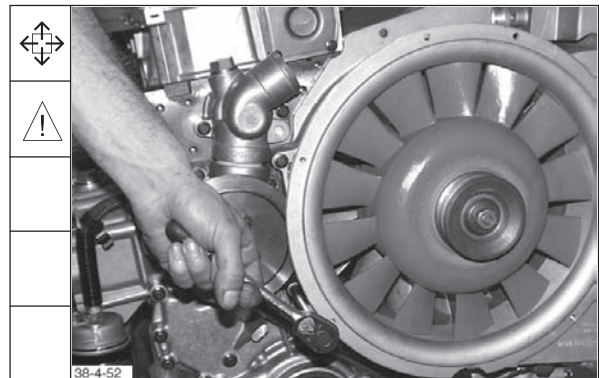

26. Kabelverbindungen trennen.

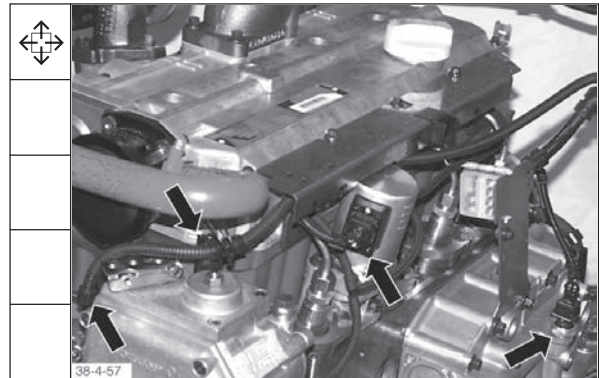

27. Kabelbaum abbauen.

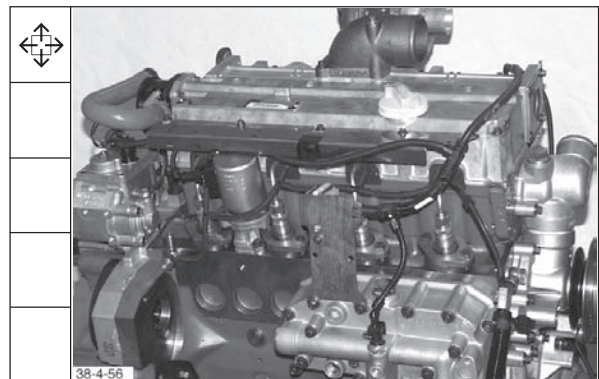



**Demontage und Montage, Motor komplett**  
**Disassembly and reassembly of complete engine**  
**Démontage et montage moteur complet**  
**Smontaggio e rimontaggio completo del motore**

Werkstatthandbuch BFM 1012/E, BFM 1013/E

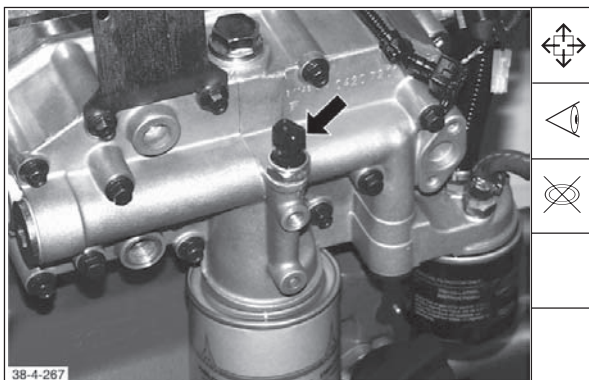
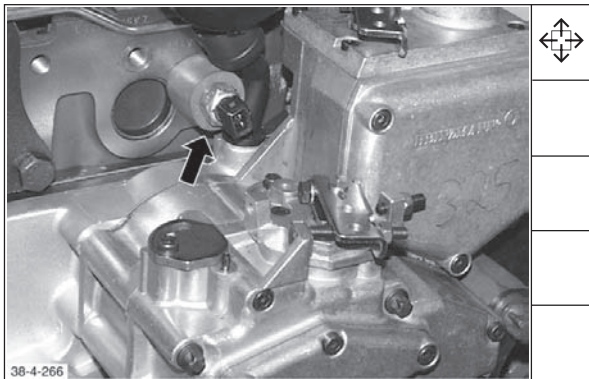

Deutsch

28. Kühlmitteltemperaturgeber ausbauen.

29. Öldruckschalter ausbauen.

Alle Bauteile sichtprüfen. Schadhafte  
Bauteile austauschen.

**Demontage und Montage, Motor komplett**  
**Disassembly and reassembly of complete engine**  
**Démontage et montage moteur complet**  
**Smontaggio e rimontaggio completo del motore**

English	Français	Italiano
28. Remove coolant temperature sensor.	28. Déposer l'interrupteur de température de réfrigérant.	28. Smontare il sensore della temperatura del liquido refrigerante.
29. Remove oil pressure switch.  Inspect all components, replace if damaged.	29. Déposer le manostat de pression d'huile.  Contrôler visuellement tous les composants. Remplacer ceux qui sont détériorés.	29. Smontare l'interrupteur pressostatico dell'olio.  Controllare tutti i componenti. Sostituire i componenti danneggiati.

**Demontage und Montage, Motor komplett**  
**Disassembly and reassembly of complete engine**  
**Démontage et montage moteur complet**  
**Smontaggio e rimontaggio completo del motore**

English	Français	Italiano
<p><b>Refitting components:</b></p>	<p><b>Repose des éléments:</b></p>	<p><b>Montaggio dei componenti:</b></p>
<p><b>Oil pressure switch/ Coolant temperature sensor</b></p>	<p><b>Manocontact de pression d'huile/ capteur de température de réfrigérant</b></p>	<p><b>Interruttore pressostatico dell'olio/ Sensore della temperatura del liquido refrigerante</b></p>
<p>30. Fit oil pressure switch with new Cu seal and tighten with a torque of <b>18 ± 2 Nm</b>.</p>	<p>30. Monter l'interrupteur de pression d'huile avec une bague neuve Cu puis serrer au couple de <b>18 ± 2 Nm</b>.</p>	<p>30. Montare il nuovo interruttore pressostatico dell'olio con un nuovo anello di tenuta in rame e serrarlo con una coppia di <b>18 ± 2 Nm</b>.</p>
<p>31. Fit coolant temperature sensor with new Cu seal and tighten with a torque of <b>18 ± 2 Nm</b>.</p>	<p>31. Monter l'interrupteur de température de réfrigérant avec une bague Cu neuve et serrer au couple de <b>18 ± 2 Nm</b>.</p>	<p>31. Montare il nuovo sensore della temperatura del liquido refrigerante con un nuovo anello di tenuta in rame e serrarlo con una coppia di <b>18 ± 2 Nm</b>.</p>
<p><b>Cable harness</b></p>	<p><b>Faisceau de câbles</b></p>	<p><b>Cablaggio preassemblato</b></p>
<p>32. Fit cable harness.</p>	<p>32. Monter le faisceau de câbles.</p>	<p>32. Montare il cablaggio preassemblato.</p>
<p>33. Tighten fastening bolts with a torque of <b>21 ± 2 Nm</b>.</p>	<p>33. Serrer les vis de fixation au couple de <b>21 ± 2 Nm</b>.</p>	<p>33. Serrare le viti di fissaggio con una coppia di <b>21 ± 2 Nm</b>.</p>



Deutsch

Werkstatthandbuch BFM 1012/E, BFM 1013/E

Bauteile anbauen:

Öldruckschalter/  
Kühlmitteltemperaturgeber

30. Öldruckschalter mit neuem Cu-Ring  
anbauen und mit einem Drehmoment von  
**18 ± 2 Nm** festdrehen.

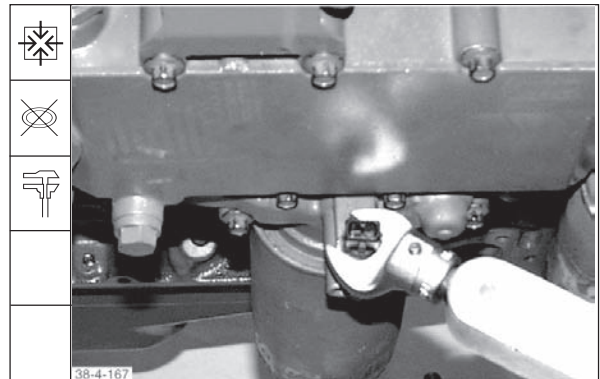

31. Kühlmitteltemperaturgeber mit neuem  
Cu-Ring anbauen und mit einem  
Drehmoment von **18 ± 2 Nm** festdrehen.

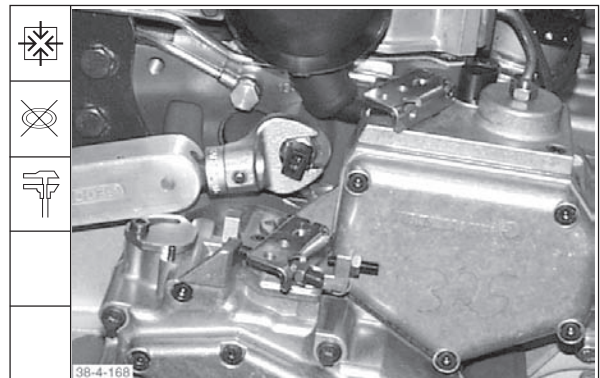

Kabelbaum

32. Kabelbaum anbauen.

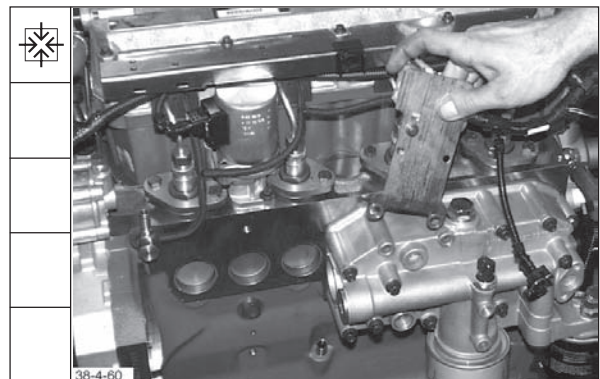

33. Befestigungsschrauben mit einem Dreh-  
moment von **21 ± 2 Nm** festdrehen.

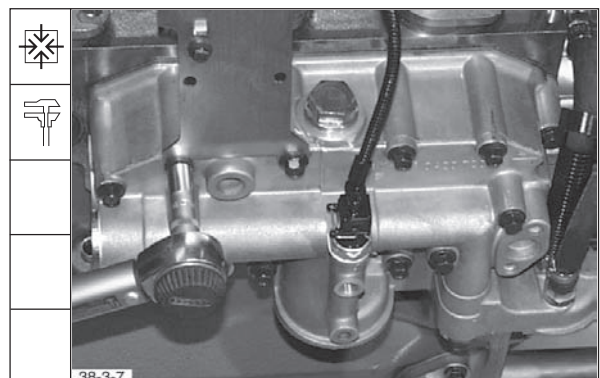

**Demontage und Montage, Motor komplett**  
**Disassembly and reassembly of complete engine**  
**Démontage et montage moteur complet**  
**Smontaggio e rimontaggio completo del motore**

Werkstatthandbuch BFM 1012/E, BFM 1013/E

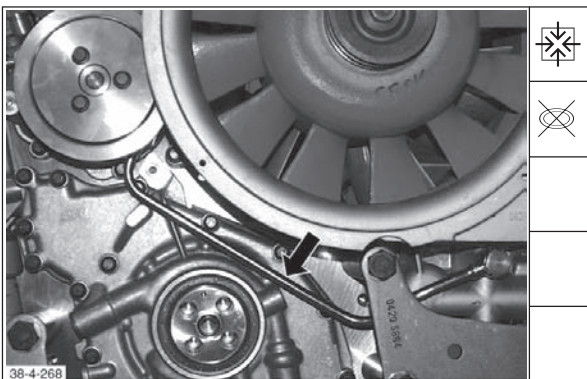
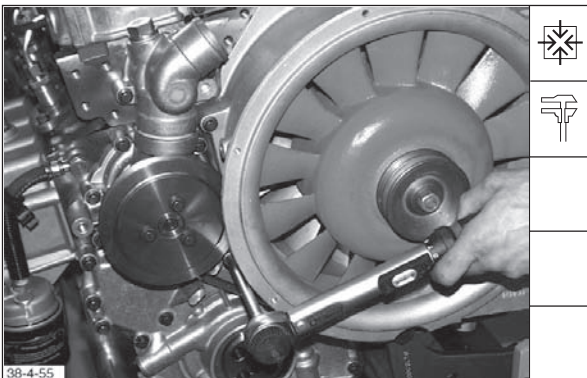
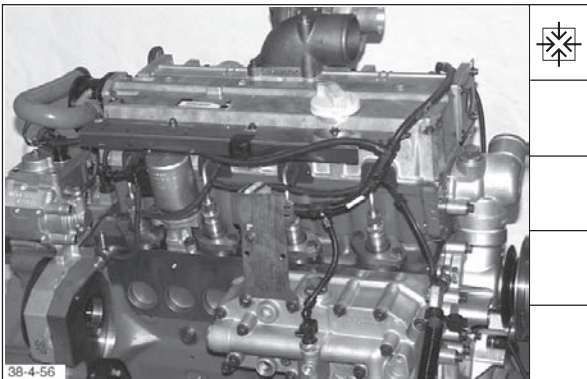

**Deutsch**

34. Kabelbaum verlegen und mit Haltebänder befestigen.

**Kühlgebläseträger**

35. Kühlgebläseträger kompl. mit Keilriemenanschlag anbauen und mit einm Drehmoment von **21 ± 2 Nm** festdrehen.

36. Kühlmittelausgleichsleitung mit neuen Cu-Ringen anbauen.

37. Neue Runddichtringe aufziehen.

**Hinweis:** Runddichtringe mit Montagegleitmittel **AP 25 N** bestreichen.

**Demontage und Montage, Motor komplett**  
**Disassembly and reassembly of complete engine**  
**Démontage et montage moteur complet**  
**Smontaggio e rimontaggio completo del motore**

English	Français	Italiano
34. Lay cable harness and fasten with holding straps.	34. Poser la faisceau de câbles et fixer à l'aide de colliers.	34. Installare il cablaggio preassemblato e fissarlo con le apposite fascette.
<b>Blower carrier</b>	<b>Support de soufflante de refroidissement</b>	<b>Supporto della soffiante di raffreddamento</b>
35. Fit blower carrier complete with V-belt stop and secure with a torque of <b>21 ± 2 Nm</b> .	35. Monter entièrement le support de soufflante et la butée de courroie, puis serrer au couple de <b>21 ± 2 Nm</b> .	35. Montare il supporto della soffiante di raffreddamento completo di arresto per la cinghia trapezoidale e bloccarlo con una coppia di <b>21 ± 2 Nm</b> .
36. Fit coolant compensating pipe with new Cu seals.	36. Monter la conduite de compensation de réfrigérant avec des bagues Cu neuves.	36. Montare la tubazione di compenso le liquido refrigerante con nuovi anelli di tenuta in rame.
37. Slide on new O-seals.	37. Monter des joints toriques neufs.	37. Infilare nuovi O-ring.
<b>Note:</b> Apply lubricant <b>AP 25N</b> to O-seals.	<b>Nota:</b> enduire les joints toriques de lubrifiant de montage type <b>AP 25N</b> .	<b>Nota:</b> Lubrificare leggermente gli O-ring col lubrificante <b>AP 25 N</b> .

**Demontage und Montage, Motor komplett**  
**Disassembly and reassembly of complete engine**  
**Démontage et montage moteur complet**  
**Smontaggio e rimontaggio completo del motore**

English	Français	Italiano
38. Insert coolant. Tighten bolts with a torque of <b>28 Nm</b> .	38. Placer un tube de réfrigérant. Serrer les vis au couple de <b>28 Nm</b> .	38. Inserire il condotto del liquido refrigerante. Serrare la vite con una coppia di <b>28 Nm</b> .
<b>Vibration damper/V-belt pulley</b>	<b>Amortisseur de vibrations/poulie à gorge</b>	<b>Smorzatore delle vibrazioni torsionali/Puleggia della cinghia trapezoidale</b>
39. Fit V-belt pulley and vibration damper.	39. Déposer la poulie à gorge et l'amortisseur de vibrations.	39. Montare la puleggia della cinghia trapezoidale assieme allo smorzatore delle vibrazioni torsionali.
40. Fit V-belt pulley and retain against flywheel. Tighten bolts according to specification.	40. Monter la poulie à gorge et la maintenir au niveau du volant. Serrer les vis selon le serrage d'approche.	40. Posizionare la puleggia della cinghia trapezoidale e tenerla contro il volante. Serrare le viti in base alle prescrizioni.
Initial tightening torque: <b>40-50 Nm</b>	Valeur de préserrage <b>40-50 Nm</b>	Preserraggio: <b>40-50 Nm</b>
1st tightening angle	1er serrage à l'angle	I ripasso:
bolts 60 mm long <b>60°</b>	Vis 60 mm de long <b>60°</b>	viti lunghe 60 mm <b>60°</b>
bolts 80 mm long <b>60°</b>	Vis 80 mm de long <b>60°</b>	viti lunghe 80 mm <b>60°</b>
2nd tightening angle	2e serrage à l'angle	Il ripasso:
bolts 60 mm long <b>30°</b>	Vis 60 mm de long <b>30°</b>	viti lunghe 60 mm <b>30°</b>
bolts 80 mm long <b>60°</b>	Vis 80 mm de long <b>60°</b>	viti lunghe 80 mm <b>60°</b>
<b>Note:</b> Use Torx socket wrench E20. Bolts may be used max. <b>5x</b> if evidence can be furnished concerning their use.	<b>Nota:</b> utiliser la clé à douille Torx E20. Les vis peuvent être utilisées selon la pratique, <b>5 fois</b> au maximum.	<b>Nota:</b> Fare uso della chiave a tubo E20 Torx. Se è documentabile, le viti possono venire utilizzate al massimo <b>5 volte</b> .
41. Fit fuel pump loosely.	41. Reposer la pompe à l'huile sans serrer.	41. Posizionare la pompa del combustibile senza bloccarla.

**Deutsch**

**Werkstatthandbuch BFM 1012/E, BFM 1013/E**

38. Kühlmittelrohr einsetzen. Schraube mit einem Drehmoment von **28 Nm** festdrehen.

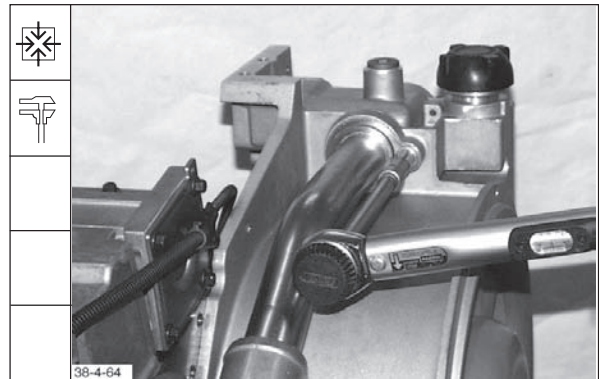

**Schwingungsdämpfer/Keilriemenscheibe**

39. Keilriemenscheibe mit Schwingungsdämpfer anbauen.

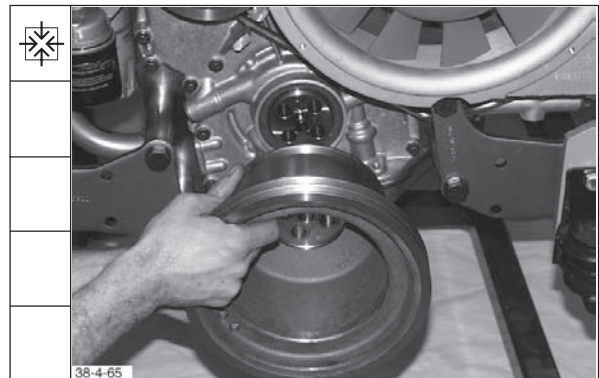

40. Keilriemenscheibe anbauen und am Schwungrad gegenhalten. Schrauben nach Anziehvorschrift festdrehen.

Vorspannwert: \_\_\_\_\_ **40-50 Nm**

1. Nachspannwinkel  
 Schrauben 60 mm lang \_\_\_\_\_ **60°**  
 Schrauben 80 mm lang \_\_\_\_\_ **60°**

2. Nachspannwinkel  
 Schrauben 60 mm lang \_\_\_\_\_ **30°**  
 Schrauben 80 mm lang \_\_\_\_\_ **60°**

**Hinweis:** Torx Steckschlüssel E20 verwenden. Schrauben können bei Nachweisbarkeit **max. 5x** verwendet werden.

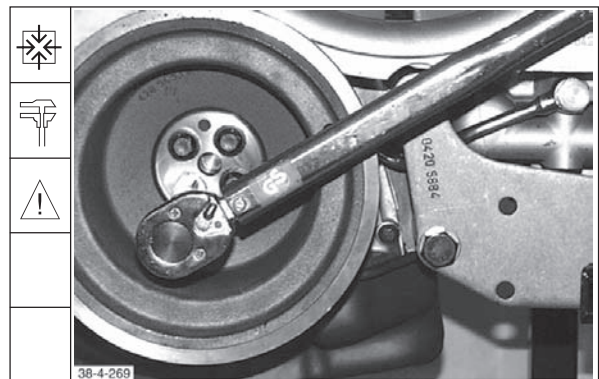

41. Kraftstoffpumpe lose anbauen.

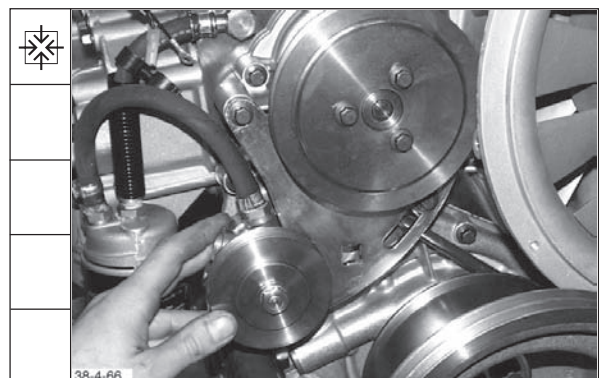



**Demontage und Montage, Motor komplett**  
**Disassembly and reassembly of complete engine**  
**Démontage et montage moteur complet**  
**Smontaggio e rimontaggio completo del motore**

**Werkstatthandbuch BFM 1012/E, BFM 1013/E**

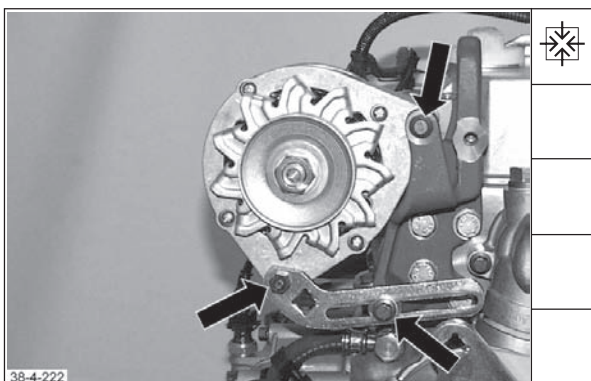
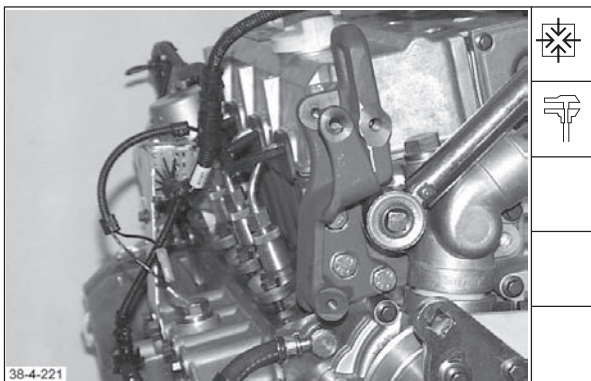
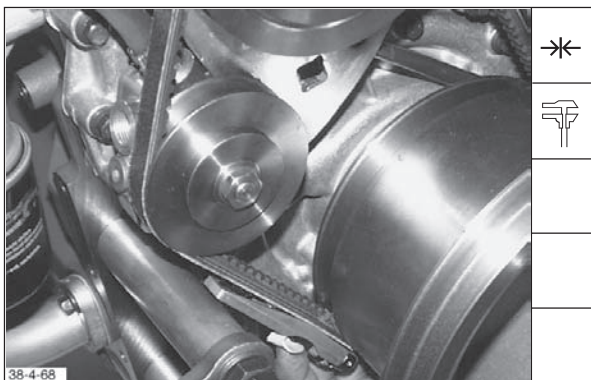
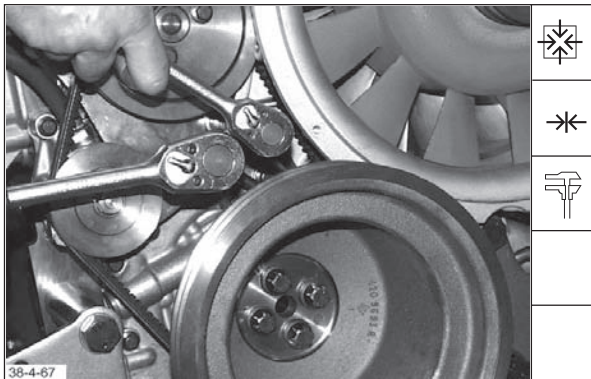

**Deutsch**

42. Keilriemen auflegen und spannen.  
 Schrauben mit einem Drehmoment von **21 ± 2 Nm** festdrehen.

43. Keilriemenspannung mit einem Spannungsmeßgerät prüfen.

Riemenrückenbreite 10 mm	
Erstmontage _____	<b>450 ± 50 N</b>
Kontrolle nach 15 min. Lauf unter Last _____	<b>300 ± 50 N</b>
Bei Wiederverwendung _____	<b>300 ± 50 N</b>

Riemenrückenbreite 13 mm	
Erstmontage _____	<b>550 ± 50 N</b>
Kontrolle nach 15 min. Lauf unter Last _____	<b>400 ± 50 N</b>
Bei Wiederverwendung _____	<b>400 ± 50 N</b>

44. Generatorkonsole anbauen und mit einem Drehmoment von **60 Nm** festdrehen.

45. Generator anbauen. Schrauben leicht andrehen.

**Demontage und Montage, Motor komplett**  
**Disassembly and reassembly of complete engine**  
**Démontage et montage moteur complet**  
**Smontaggio e rimontaggio completo del motore**

English	Français	Italiano
<p>42. Position V-Belt in place and tension. Tighten bolts with a torque of <b>21 ± 2 Nm</b>.</p>	<p>42. Placer la courroie trapézoïdale et tendre. Serrer les vis au couple de <b>21 ± 2 Nm</b>.</p>	<p>42. Montare la cinghia trapezoidale e tenderla. Serrare le viti con una coppia di <b>21 ± 2 Nm</b>.</p>
<p>43. Check V-belt tension with belt tension gauge.</p> <p>Belt back width 10 mm            Initial assembly _____ <b>450 ± 50 N</b>            Check value after 15 min. of operation under load _ <b>300 ± 50 N</b>            When reusing belt ____ <b>300 ± 50 N</b></p> <p>Belt back width 13 mm            Initial assembly        <b>550 ± 50 N</b>            Check value after 15 min. of operation under load <b>400 ± 50 N</b>            When reusing belt ____ <b>400 ± 50 N</b></p>	<p>43. Contrôler la tension de la courroie trapézoïdale à l'aide d'un tensiomètre.</p> <p>Largeur du dos de la courroie 10 mm            Première monte _____ <b>450 ± 50 N</b>            Contrôle après 15 min. de marche            Sous charge _____ <b>300 ± 50 N</b>            Après réutilisation ____ <b>300 ± 50 N</b></p> <p>Largeur du dos de la couronne 13 mm            Première monte _____ <b>550 ± 50 N</b>            Contrôle après 15 min. de marche            Sous charge _____ <b>400 ± 50 N</b>            Après réutilisation ____ <b>400 ± 50 N</b></p>	<p>43. Controllare la tensione della cinghia con uno strumento di misura della tensione            Cinghia con dorso di 10 mm            Primo montaggio _____ <b>450 ± 50 N</b>            Controllo dopo 15 minuti di _____            funzion. sotto carico _ <b>300 ± 50 N</b>            Quando si riutilizza ____ <b>300 ± 50 N</b></p> <p>Cinghia con dorso di 13 mm            Primo montaggio _____ <b>550 ± 50 N</b>            Controllo dopo 15 minuti di _____            funzion. sotto carico _ <b>400 ± 50 N</b>            Quando si riutilizza ____ <b>400 ± 50 N</b></p>
<p>44. Fit alternator bracket and secure within a torque of <b>60 Nm</b>.</p>	<p>44. Monter la console de l'alternateur et serrer au couple <b>60 Nm</b>.</p>	<p>44. Montare la mensola del generatore e serrarla con una coppia di <b>60 Nm</b>.</p>
<p>45. Mount alternator. Start bolts.</p>	<p>45. Monter l'alternateur et serrer les vis modérément.</p>	<p>45. Montare il generatore. Avvitare a mano le viti.</p>

**Demontage und Montage, Motor komplett**  
**Disassembly and reassembly of complete engine**  
**Démontage et montage moteur complet**  
**Smontaggio e rimontaggio completo del motore**

English	Français	Italiano
46. Position V-belt in place and tension. Tighten bolts with a torque of <b>31 Nm</b> . Turn belt drive 2-3 revolutions.	46. Placer la courroie trapézoïdale et tendre. Serrer les vis au couple de <b>31 Nm</b> . Virer l'entraînement de courroie de 2 à 3 tours.	46. Montare la cinghia trapezoidale e tenderla. Serrare le viti con una coppia di <b>31 Nm</b> . Far fare 2 o 3 giri alla trasmissione a cinghia.
47. Check V-belt tension with belt tension gauge.  Initial assembly _____ <b>450 ± 50 N</b> Check value after 15 min. of operation under load _ <b>300 ± 50 N</b> When reusing belt ____ <b>300 ± 50 N</b>	47. Contrôler la tension de la courroie trapézoïdale à l'aide d'un tensiomètre.  Première monte _____ <b>450 ± 50 N</b> Contrôle après 15 min. Marche sous charge _ <b>300 ± 50 N</b> Après réutilisation ____ <b>300 ± 50 N</b>	47. Controllare la tensione della cinghia trapezoidale per mezzo dell'apposito strumento di misura. Primo montaggio _____ <b>450 ± 50 N</b> Controllo dopo 15 minuti di _____ funzion. sotto carico _ <b>300 ± 50 N</b> Quando si riutilizza ____ <b>300 ± 50 N</b>
48. Fit air guide ring. Tighten bolts and nuts with a torque of <b>11 Nm</b> .	48. Monter le diffuseur d'air. Serrer les vis et les écrous au couple de <b>11 Nm</b> .	48. Montare l'imbuto per l'aria. Serrare viti e dadi con una coppia di <b>11 Nm</b> .
49. Fit tension pulley together with bracket and secure with a torque of <b>29 Nm</b> .	49. Monter le galet tendeur et la console et serrer au couple de <b>29 Nm</b> .	49. Montare il rullo tendicinghia completo di mensola e bloccarlo con una coppia di <b>29 Nm</b> .



**Deutsch**

**Werkstatthandbuch BFM 1012/E, BFM 1013/E**

46. Keilriemen auflegen und spannen.  
 Schrauben mit einem Drehmoment von **31 Nm** festdrehen.  
 Riementrieb 2-3 Umdrehungen durchdrehen.

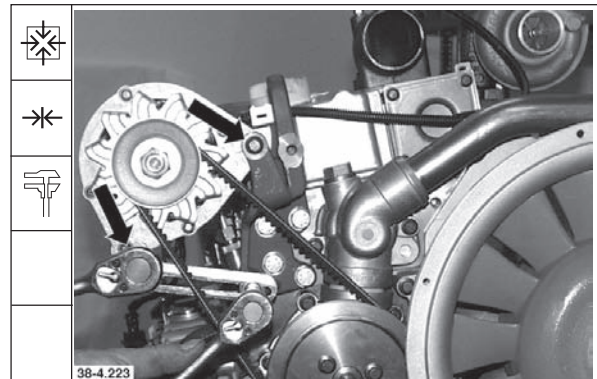

47. Keilriemenspannung mit Spannungsmeßgerät prüfen.

Erstmontage \_\_\_\_\_ **450 ± 50 N**  
 Kontrolle nach 15 min.  
 Lauf unter Last \_\_\_\_\_ **300 ± 50 N**  
 Bei Wiederverwendung \_\_\_\_\_ **300 ± 50 N**

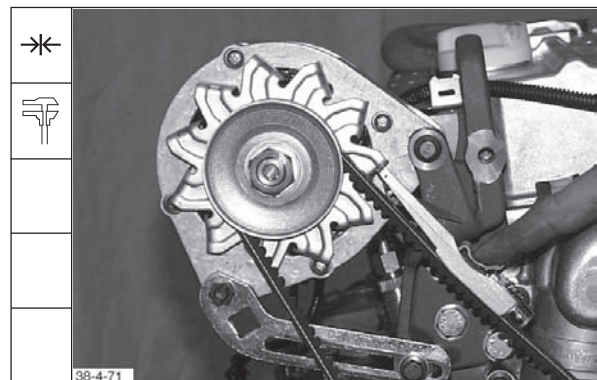

48. Luftrichter anbauen. Schrauben und Muttern mit einem Drehmoment von **11 Nm** festdrehen.

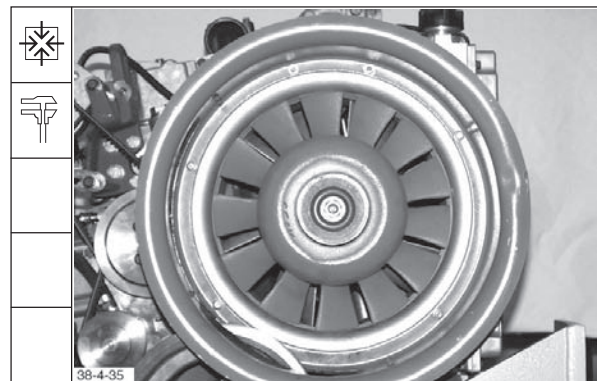

49. Spannrolle mit Konsole anbauen und mit einem Drehmoment von **29 Nm** festdrehen.

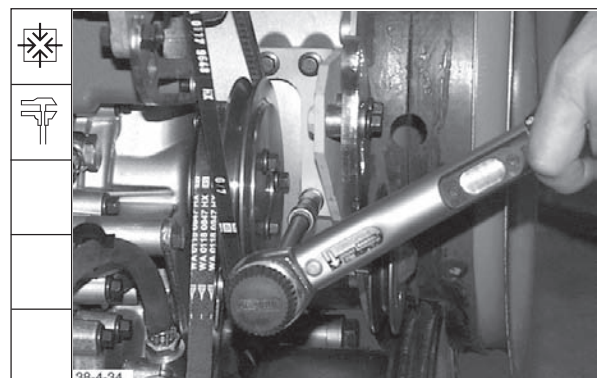

**Demontage und Montage, Motor komplett**  
**Disassembly and reassembly of complete engine**  
**Démontage et montage moteur complet**  
**Smontaggio e rimontaggio completo del motore**

Werkstatthandbuch BFM 1012/E, BFM 1013/E

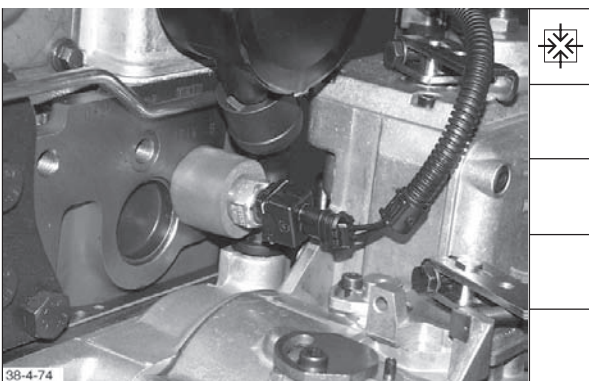
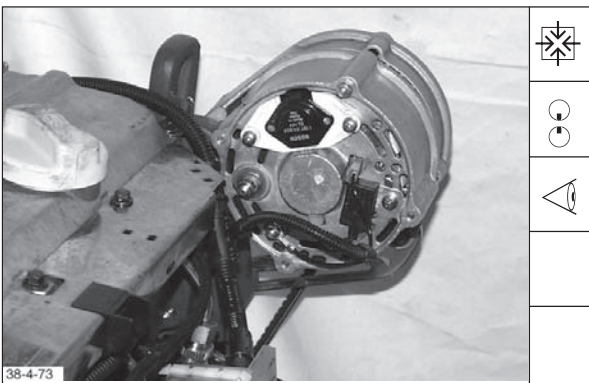
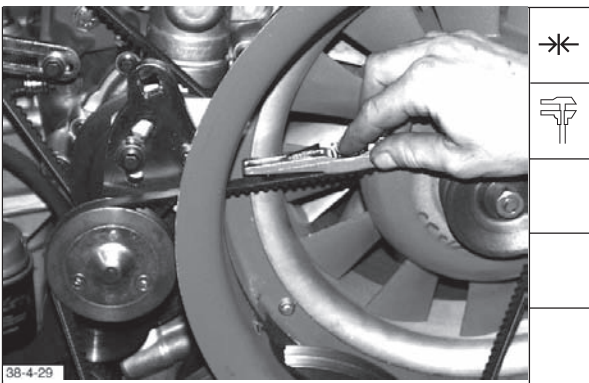
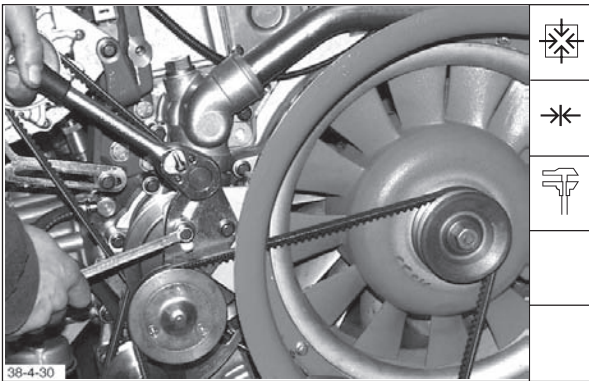

**Deutsch**

49.1 Keilriemen auflegen und spannen.  
 Schrauben mit einem Drehmoment von **29 Nm** festdrehen.

50. Keilriemenspannung mit Spannungs-  
 meßgerät prüfen.

Erstmontage \_\_\_\_\_ **450 ± 50 N**

Kontrolle nach 15 min.

Lauf unter Last \_\_\_\_\_ **300 ± 50 N**

Bei Wiederverwendung \_\_\_\_\_ **300 ± 50 N**

51. Kabel anbauen.

52. Kabel für Kühlmitteltemperaturgeber  
 anbauen.

**Demontage und Montage, Motor komplett**  
**Disassembly and reassembly of complete engine**  
**Démontage et montage moteur complet**  
**Smontaggio e rimontaggio completo del motore**

English	Français	Italiano
49.1 Position V-belt in place and tension. Tighten bolts with a torque of <b>29 Nm</b> .	49.1 Placer la courroie trapézoïdale et tendre. Serrer les vis au couple de <b>29 Nm</b> .	49.1 Montare la cinghia trapezoidale e tenderla. Serrare le viti con una coppia di <b>29 Nm</b> .
50. Check V-belt tension with belt tension gauge.  Initial assembly ____ <b>450 ± 50 N</b> Check value after 15 min. of operation under load _ <b>300 ± 50 N</b> When reusing belt _ <b>300 ± 50 N</b>	50. Contrôler la tension de la courroie trapézoïdale à l'aide d'un tensionmètre.  Première monte ____ <b>450 ± 50 N</b> Contrôle après 15 min. Marche sous charge _ <b>300 ± 50 N</b> Après réutilisation ____ <b>300 ± 50 N</b>	50. Controllare la tensione della cinghia trapezoidale per mezzo dell'apposito strumento di misura.  Primo montaggio ____ <b>450 ± 50 N</b> Controllo dopo 15 minuti di ____ funzion. sotto carico _ <b>300 ± 50 N</b> Quando si riutilizza ____ <b>300 ± 50 N</b>
51. Fit cable.	51. Monter le câble.	51. Montare il cavo.
52. Fit cable for coolant temperature sensor.	52. Monter le câble du capteur de température du réfrigérant.	52. Montare il cavo per il sensore della temperatura del liquido refrigerante.

**Demontage und Montage, Motor komplett**  
**Disassembly and reassembly of complete engine**  
**Démontage et montage moteur complet**  
**Smontaggio e rimontaggio completo del motore**

English	Français	Italiano
<p><b>Coolant pipe</b></p> <p>53. Slide on new O-seals.</p> <p><b>Note:</b> Apply lubricant <b>AP 25 N</b> to O-seals</p>	<p><b>Tuyau de réfrigérant</b></p> <p>53. Monter des joints toriques neufs.</p> <p><b>Nota:</b> enduire les joints toriques de lubrifiant de montage <b>AP 25 N</b>.</p>	<p><b>Condotto del liquido refrigerante.</b></p> <p>53. Infilarci nuovi O-ring.</p> <p><b>Nota:</b> Oliare gli O-ring col lubrificante <b>AP 25 N</b>.</p>
<p>54. Preassemble coolant pipe with flange.</p>	<p>54. Préassembler le tuyau de réfrigérant avec la bride.</p>	<p>54. Assemblare con la sua flangia il condotto del liquido refrigerante.</p>
<p>55. Apply sealing compound <b>DEUTZ DW 67</b> to flange sealing surface. Fit coolant pipe.</p>	<p>55. Enduire la plan de joint de la bride à l'aide d'unproduit d'étanchéité <b>DEUTZ DW 67</b>. Monter le tuyau de réfrigérant.</p>	<p>55. Spalmare l'ermetico <b>DEUTZ DW 67</b> sulla superficie di tenuta della flangia. Montare il condotto del liquido refrigerante.</p>
<p>56. Tighten bolts with a torque of <b>28 Nm</b>.</p> <p><b>Note:</b> Pay attention to correct position of locking washer.</p>	<p>56. Serrer les vis au couple de <b>28 Nm</b>.</p> <p><b>Nota:</b> veiller au bon positionnement de la rondelle d'arrêt.</p>	<p>56. Serrare le viti con una coppia di <b>28 Nm</b>.</p> <p><b>Nota:</b> Assicurarsi che la rondella di sicurezza si trovi nella posizione corretta.</p>

Deutsch

Werkstatthandbuch BFM 1012/E, BFM 1013/E

Kühlmittelrohr

53. Neue Runddichtringe aufziehen.

**Hinweis:** Runddichtringe mit Montagegleitmittel **AP 25 N** bestreichen.

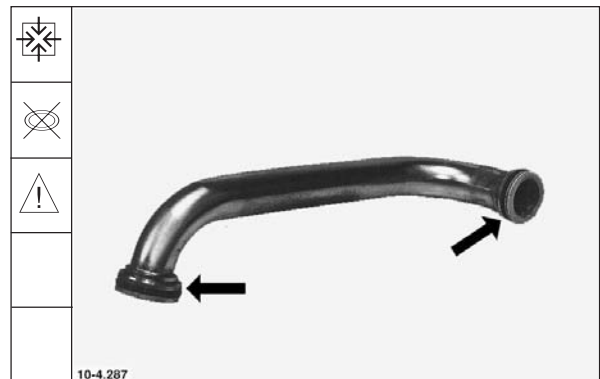

54. Kühlmittelrohr mit Flansch vormontieren.



55. Dichtfläche des Flansches mit Dichtmasse **DEUTZ DW 67** bestreichen. Kühlmittelrohr anbauen.

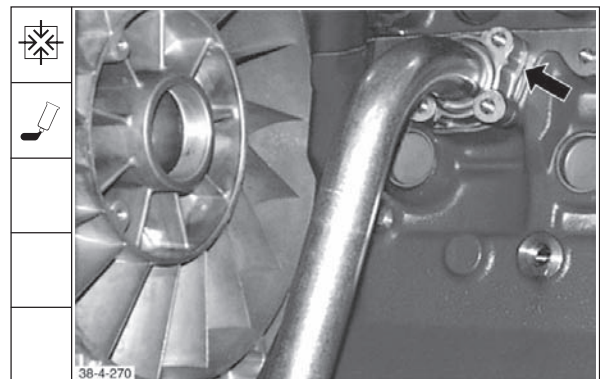

56. Schrauben mit einem Drehmoment von **28 Nm** festdrehen.

**Hinweis:** Auf richtige Position der Sicherungsscheibe achten.

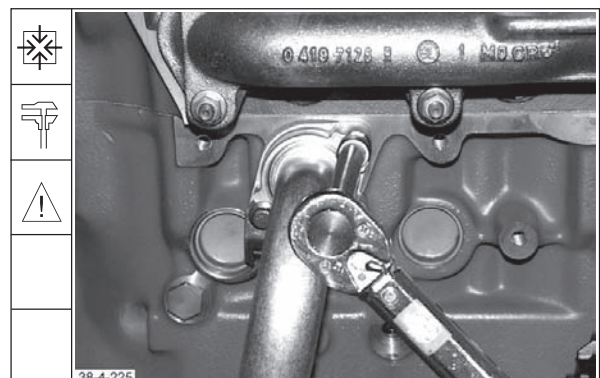



**Demontage und Montage, Motor komplett**  
**Disassembly and reassembly of complete engine**  
**Démontage et montage moteur complet**  
**Smontaggio e rimontaggio completo del motore**

Werkstatthandbuch BFM 1012/E, BFM 1013/E

Deutsch

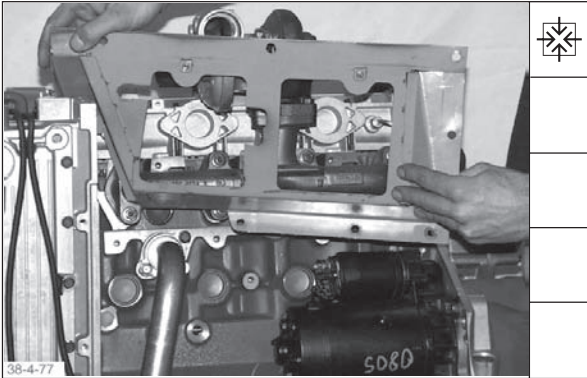

**Verblechung**

57. Abdeckblech anbauen.



**Ölrücklaufrohr/Druckölleitung**

58. Neue Runddichtringe aufziehen und fetten.

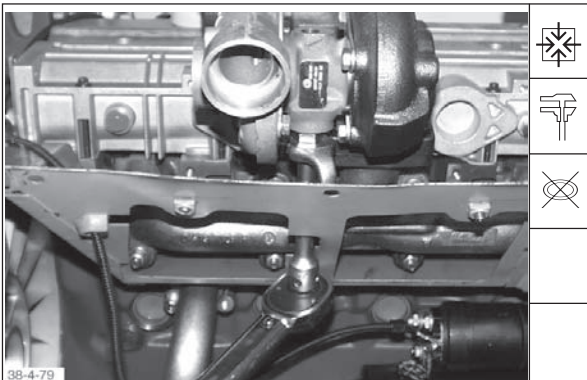

59. Einschraubstutzen mit neuem Cu-Dichtring mit einem Drehmoment von **40 ± 2 Nm** festdrehen.

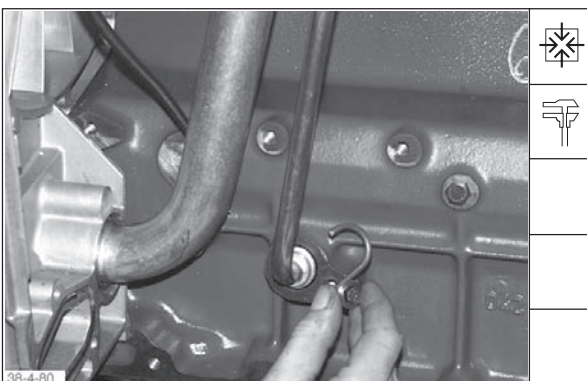

60. Ölrücklaufleitung und Halter anbauen. Schraube mit einem Drehmoment von **22 ± 2 Nm** festdrehen.

**Demontage und Montage, Motor komplett**  
**Disassembly and reassembly of complete engine**  
**Démontage et montage moteur complet**  
**Smontaggio e rimontaggio completo del motore**

English	Français	Italiano
<p><b>Panelling</b></p> <p>57. Fit cover plate.</p>	<p><b>Tôle</b></p> <p>57. Monter la tôle de recouvrement.</p>	<p><b>Lamierati</b></p> <p>57. Montare la lamiera di protezione.</p>
<p><b>Oil return pipe/pressure oil pipe</b></p> <p>58. Slide on new O-seals and grease.</p>	<p><b>Tuyau de retour d'huile/conduite de refoulement d'huile</b></p> <p>58. Monter les joint toriques neufs et graisser.</p>	<p><b>Tubazione di ritorno dell'olio/ Tubazione di mandata dell'olio</b></p> <p>58. Infilare nuovi O-ring ed ingrassarli.</p>
<p>59. Tighten screw plug with new Cu seal with a torque of <b>40 ± 2 Nm</b>.</p>	<p>59. Serrer les tubulures à visser avec un joint d'étanchiété au couple de <b>40 ± 2 Nm</b>.</p>	<p>59. Dopo averlo munito di un nuovo anello di tenuta in rame, serrare il manicotto filettato con una coppia di <b>40 ± 2 Nm</b>.</p>
<p>60. Fit oil return pipe and retainer. Tighten bolt with a torque of <b>22 ± 2 Nm</b>.</p>	<p>60. Monter le tuyau de retour d'huile et le support. Serrer la vis au couple de <b>22 ± 2 Nm</b>.</p>	<p>60. Montare la tubazione di ritorno dell'olio assieme al suo supporto. Serrare la vite con una coppia di <b>22 ± 2 Nm</b>.</p>

**Demontage und Montage, Motor komplett**  
**Disassembly and reassembly of complete engine**  
**Démontage et montage moteur complet**  
**Smontaggio e rimontaggio completo del motore**

English	Français	Italiano
<p>61. Fit pressure oil pipe. Tighten banjo bolts with new Cu seals and with a torque of  item 1 <b>29 ± 3 Nm</b>  item 2 <b>39 ± 4 Nm</b>.</p>	<p>61. Monter la conduite de refoulement d'huile. Serrer les vis creuses avec des joints d'étanchéité Cu neufs.  Pos. 1 <b>29 ± 3 Nm</b>  Pos. 2 <b>39 ± 4 Nm</b>.</p>	<p>61. Montare la tubazione di mandata dell'olio:  Dopo averle munite di un nuovo anello di tenuta in rame, serrare le viti cave con le seguenti coppie:  Pos. 1 <b>29 ± 3 Nm</b>  Pos. 2 <b>39 ± 4 Nm</b></p>
<p>62. Fit cover plate.</p>	<p>62. Monter la tôle d'extrémité.</p>	<p>62. Montare la lamiera di chiusura.</p>
<p>63. Fit cable to starter and terminal stud.</p> <p>Tightening specifications:  Hex. nut on terminal stud  <b>35 ± 4 Nm</b>  Hex. nut on starter (terminal 30)  <b>28 ± 2 Nm</b></p>	<p>63. Monter le câble sur le démarreur et le boulon de fixation.</p> <p>Consigne de serrage:  Ecrou hexagonal sur le boulon de fixation <b>35 ± 4 Nm</b>  Ecrou hexagonal sur le démarreur (borne 30) <b>28 ± 2 Nm</b></p>	<p>63. Montare il cavo tra il motorino d'avviamento ed il bullone di collegamento.  Prescrizioni di serraggio:  Dado esagonale del bullone di collegamento <b>35 ± 4 Nm</b>  Dado esagonale sul motorino d'avviamento (morsetto 30)  <b>28 ± 2 Nm</b></p>
<p>64. Introduce cable harness through cover plate. Fit rubber grommet.</p>	<p>64. Introduire le faisceau de câble par la tôle de recouvrement. Monter le passe-câble.</p>	<p>64. Far passare il cablaggio preassemblato attraverso la lamiera di protezione. Montare l'isolatore passante di gomma.</p>



Deutsch

Werkstatthandbuch BFM 1012/E, BFM 1013/E

61. Druckölleitung anbauen:

Hohlschrauben mit neuen Cu-Dichtringen  
und mit einem Drehmoment von  
Pos. 1 **29 ± 3 Nm**  
Pos. 2 **39 ± 4 Nm**  
festdrehen.

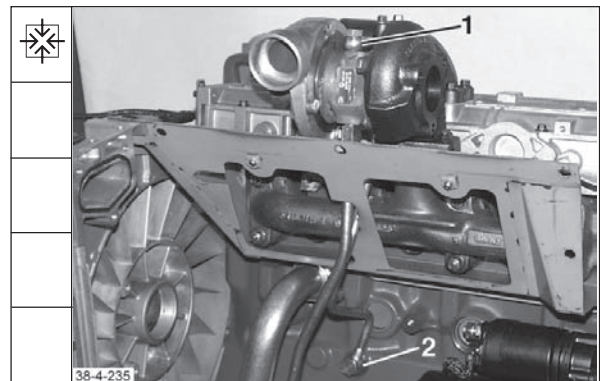

62. Abschlußblech anbauen.

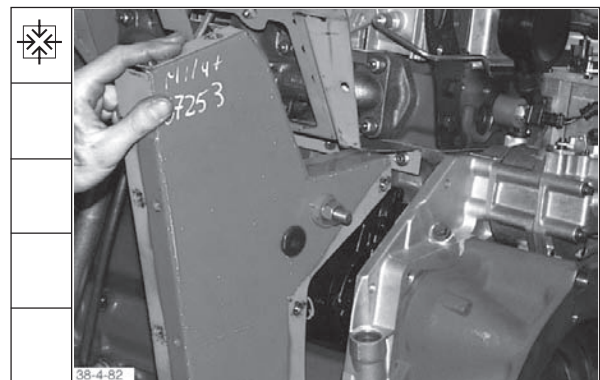

63. Kabel an Starter und Anschlußbolzen anbauen.

Anziehvorschrift:  
Sechskantmutter am Anschlußbolzen  
**35 ± 4 Nm**  
Sechskantmutter am Starter (Klemme 30)  
**28 ± 2 Nm**



64. Kabelbaum durch Abdeckblech durchführen.  
Gummitülle montieren

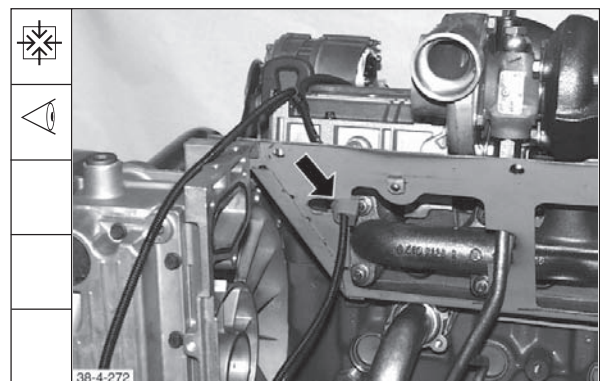

**Demontage und Montage, Motor komplett**  
**Disassembly and reassembly of complete engine**  
**Démontage et montage moteur complet**  
**Smontaggio e rimontaggio completo del motore**

Werkstatthandbuch BFM 1012/E, BFM 1013/E

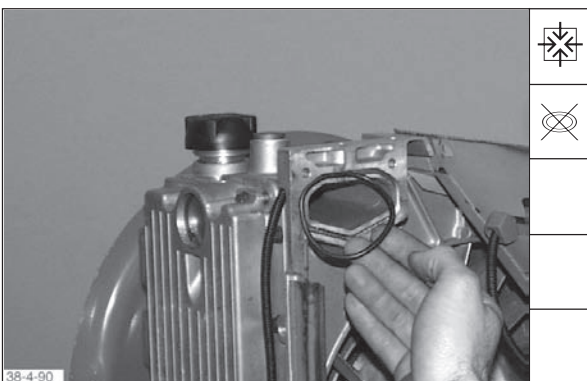
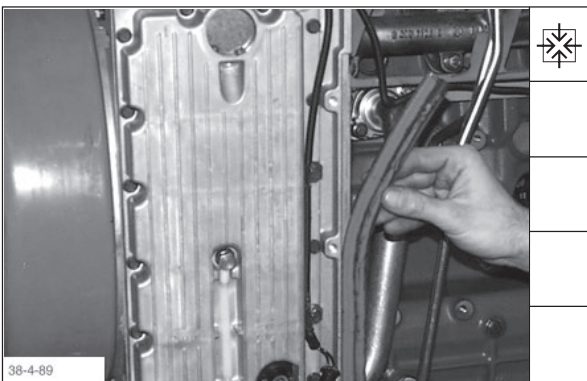
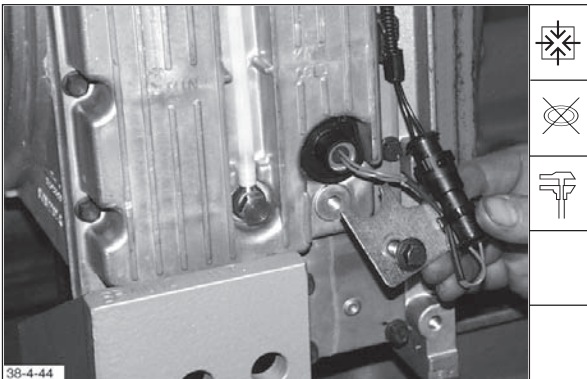

**Deutsch**

65. Niveauschalter mit neuer Gummimuffe einbauen.  
 Schraube mit einem Drehmoment von **28 Nm** festdrehen.

66. Verkabelung mit Haltebinder und Halter anbauen.  
 Schrauben mit einem Drehmoment von **9 Nm** festdrehen.

67. Klemmprofil anbauen.

**Flüssigkeitskühler**

68. Neue Runddichtringe für Flüssigkeitskühler einsetzen.

**Demontage und Montage, Motor komplett**  
**Disassembly and reassembly of complete engine**  
**Démontage et montage moteur complet**  
**Smontaggio e rimontaggio completo del motore**

English	Français	Italiano
65. Install level switch with new rubber sleeve. Tighten bolt with a torque of <b>28 Nm</b> .	65. Monter l'interrupteur du niveau avec le manchon en caoutchouc neuf. Serrer la vis au couple de <b>28 Nm</b> .	65. Montare il sensore del livello del liquido refrigerante munito di un nuovo manicotto di comma. Serrare la vite con una coppia di <b>28 Nm</b> .
66. Fit cabling with fixing strap and holder. Tighten bolts with a torque of <b>9 Nm</b> .	66. Monter le câblage avec le collier de fixation et le support. Serrer les vis au couple de <b>9 Nm</b> .	66. Montare il fascio di cavi munito di fascette e supporti. Serrare le viti con una coppia di <b>9 Nm</b> .
67. Fit clamping section.	67. Monter le profilé de serrage.	67. Montare il profilo di gomma.
<b>Radiator</b>	<b>Refroidisseur à liquide</b>	<b>Radiatore del liquido refrigerante</b>
68. Insert new O-seals for radiator.	68. Placer les joints toriques neufs dans le refroidisseur de liquide.	68. Inserire nuovi O-ring per il radiatore del liquido refrigerante.

**Demontage und Montage, Motor komplett**  
**Disassembly and reassembly of complete engine**  
**Démontage et montage moteur complet**  
**Smontaggio e rimontaggio completo del motore**

English	Français	Italiano
69. Fit retainer for radiator. Tighten bolts with a torque of <b>21 Nm</b> .	69. Monter le support du refroidisseur à liquide. Serrer les vis au couple de <b>21 Nm</b> .	69. Montare il supporto del radiatore del liquido refrigerante. Serrare le viti con una coppia di <b>21 Nm</b> .
70. Mount radiator. Tighten bolts with a torque of <b>9 ± 1 Nm</b> .	70. Monter le refroidisseur à liquide. Serrer les vis au couple de <b>9 ± 1 Nm</b> .	70. Montare il radiatore del liquido refrigerante. Serrare le viti con una coppia di <b>9 ± 1 Nm</b> .
71. Fit cover plate.	71. Monter la tôle de recouvrement.	71. Montare il lamierino di protezione.
72. Fit cover plate.	72. Monter la tôle de recouvrement.	72. Montare la lamiera laterale.

Deutsch

Werkstatthandbuch BFM 1012/E, BFM 1013/E

69. Halter für Flüssigkeitskühler anbauen.  
Schrauben mit einem Drehmoment von  
**21 Nm** festdrehen.

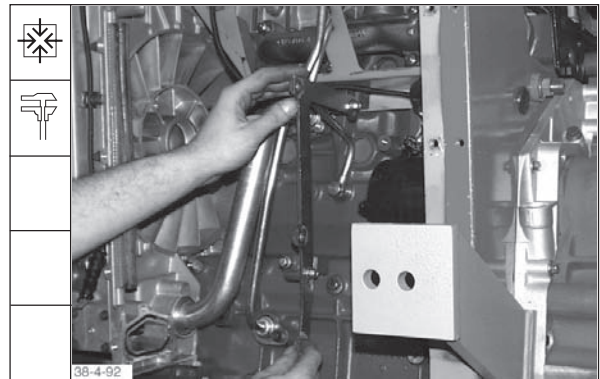

70. Flüssigkeitskühler anbauen. Schrauben mit  
einem Drehmoment von **9 ± 1 Nm**  
festdrehen.

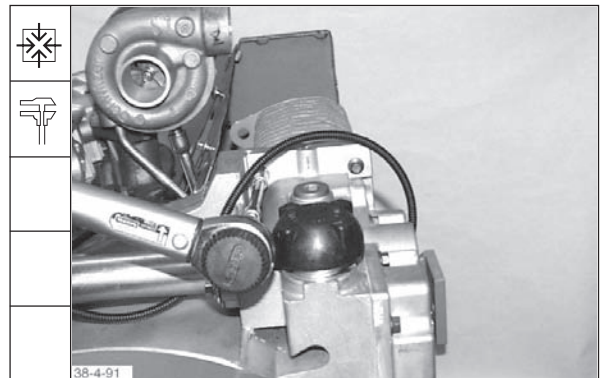

71. Abdeckblech anbauen.

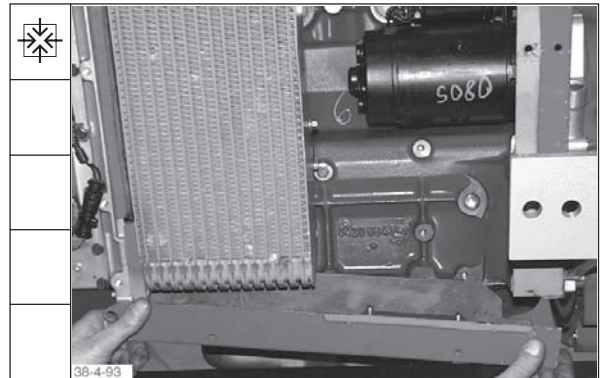

72. Abdeckblech anbauen.

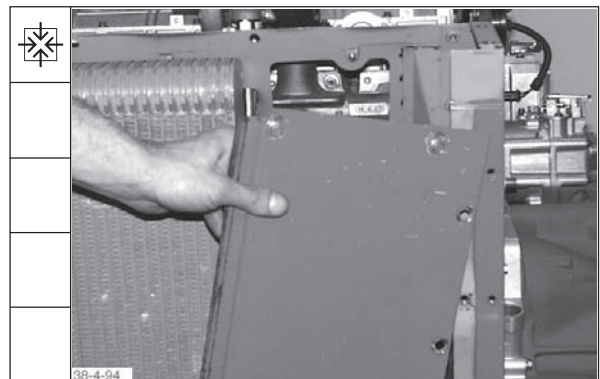



**Demontage und Montage, Motor komplett**  
**Disassembly and reassembly of complete engine**  
**Démontage et montage moteur complet**  
**Smontaggio e rimontaggio completo del motore**

**Werkstatthandbuch BFM 1012/E, BFM 1013/E**

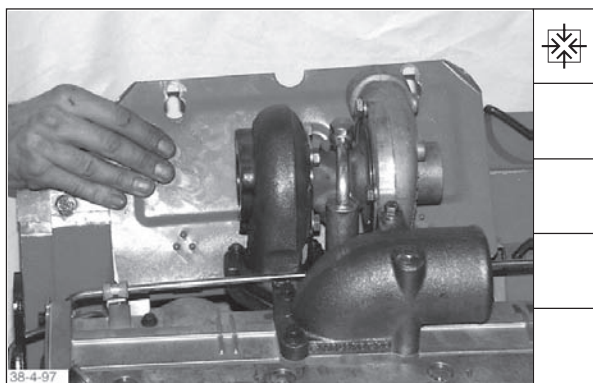
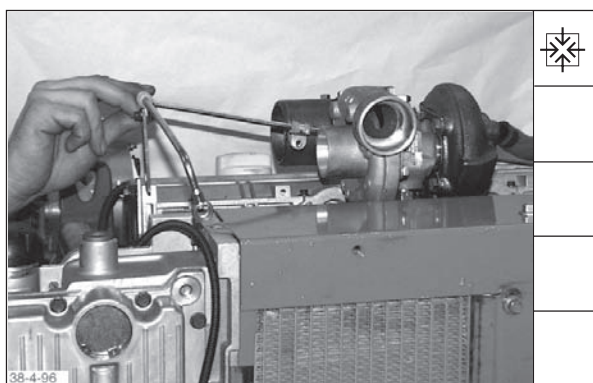
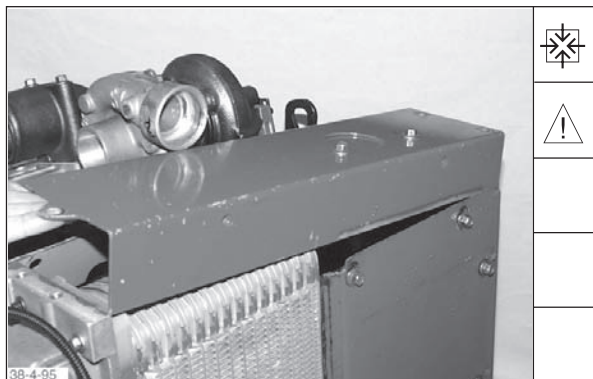

**Deutsch**

73. Abdeckblech anbauen.

**Hinweis:** Schrauben noch nicht festdrehen.

74. Entlüftungsleitung mit neuen Cu-Ringen anbauen. Halter gemeinsam mit Abdeckblech festdrehen.

75. Schaulochblech anbauen.

**Demontage und Montage, Motor komplett**  
**Disassembly and reassembly of complete engine**  
**Démontage et montage moteur complet**  
**Smontaggio e rimontaggio completo del motore**

English	Français	Italiano
73. Fit cover plate. <b>Note:</b> Do not tighten bolts yet.	73. Monter la tôle de recouvrement. <b>Nota:</b> ne pas encore serrer les vis.	73. Montare la lamiera superiore. <b>Nota:</b> Non serrare ancora le viti.
74. Fit breather pipe with new Cu seals. Tighten retainer together with cover plate.	74. Monter la conduite de dégazage avec des joints Cu neufs. Serrer le support avec la tôle de recouvrement.	74. Montare la tubazione di sfiato munita di nuovi anelli di rame. Bloccare il supporto assieme alla lamiera superiore.
75. Fit inspection hole cover plate.	75. Monter la tôle-regard.	75. Montare la lamiera col foro d'ispezione.

**Demontage und Montage, Motor komplett**  
**Disassembly and reassembly of complete engine**  
**Démontage et montage moteur complet**  
**Smontaggio e rimontaggio completo del motore**

English	Français	Italiano
<p><b>Replacing shaft seals on complete engine</b></p>	<p><b>Remplacement des joints d'arbre sur moteur complet</b></p>	<p><b>Sostituzione di tutti gli anelli paraolio del motore completo.</b></p>
<p><b>Special tools required:</b></p>	<p><b>Outillage spécial :</b></p>	<p><b>Attrezzi speciali:</b></p>
<p>Extractor for shaft seals _____ 142 710            Assembly tool, rear                BFM 1012 _____ 142 890                BFM 1013 _____ 142 910            Assembly tool, front                BFM 1012 _____ 142 900                BFM 1013 _____ 142 920</p>	<p>Extracteur de joints d'arbre _____ 142 710            Dispositif de montage AR                BFM 1012 _____ 142 890                BFM 1013 _____ 142 910            Dispositif de montage AV                BFM 1012 _____ 142 900                BFM 1013 _____ 142 920</p>	<p>Estrattore per anelli paraolio _____ 142 710            Dispositivo di montaggio posteriore:                BFM 1012 _____ 142 890                BFM 1013 _____ 142 910            Dispositivo di montaggio anteriore:                BFM 1012 _____ 142 900                BFM 1013 _____ 142 920</p>
<p><b>- Timing chest cover flywheel end -</b></p>	<p><b>- Couvercle de carter de distribution côté volant moteur -</b></p>	<p><b>- Coperchio della scatola della distribuzione sul lato volano -</b></p>
<p>Flywheel has been removed.</p>	<p>Le volant moteur a été déposé.</p>	<p>Il volano è smontato.</p>
<p>1. Press extractor into shaft seal.</p>	<p>1. Insérer le crochet extracteur dans le joint d'arbre.</p>	<p>1. Introdurre nell'anello paraolio il gancio dell'estrattore.</p>
<p>2. Lift shaft seal with extractor out of timing chest cover.</p>	<p>2. A l'aide de l'extracteur retirer le joint d'arbre du couvercle du carter de distribution.</p>	<p>2. Servendosi della leva dell'estrattore, estrarre l'anello paraolio dal coperchio della scatola della distribuzione.</p>
<p>3. Fit guide sleeve.</p>	<p>3. Monter la douille de guidage.</p>	<p>3. Montare la bussola di guida.</p>



Deutsch

Werkstatthandbuch BFM 1012/E, BFM 1013/E

**Austausch der Wellendichtringe am kompletten Motor**

**Spezialwerkzeuge:**

Ausziehvorrichtung für Wellendichtringe _____	142 710
Montagevorrichtung hinten BFM 1012 _____	142 890
BFM 1013 _____	142 910
Montagevorrichtung vorne BFM 1012 _____	142 900
BFM 1013 _____	142 920

**- Räderkastendeckel Schwungradseite -**

Schwungrad ist abgebaut.

1. Abziehhaken in den Wellendichtring eindrücken.

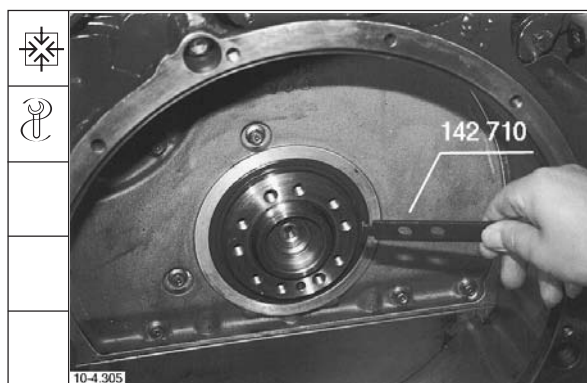

2. Wellendichtring mit Ausziehvorrichtung aus dem Räderkastendeckel hebeln.

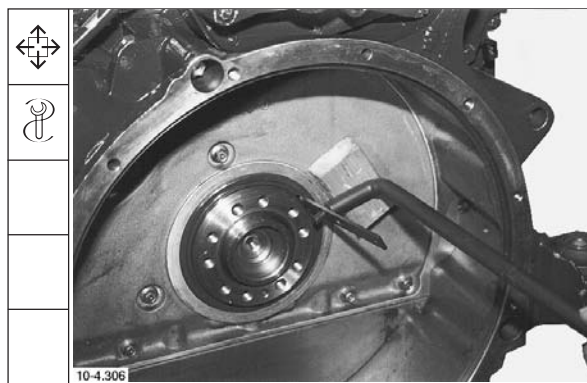

3. Führungsbuchse anbauen.

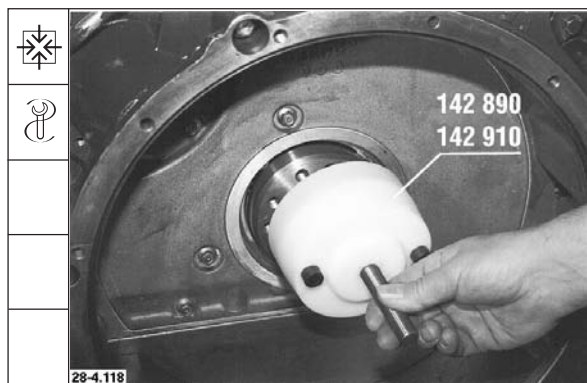

# Demontage und Montage, Motor komplett Disassembly and reassembly of complete engine Démontage et montage moteur complet Smontaggio e rimontaggio completo del motore

Werkstatthandbuch BFM 1012/E, BFM 1013/E

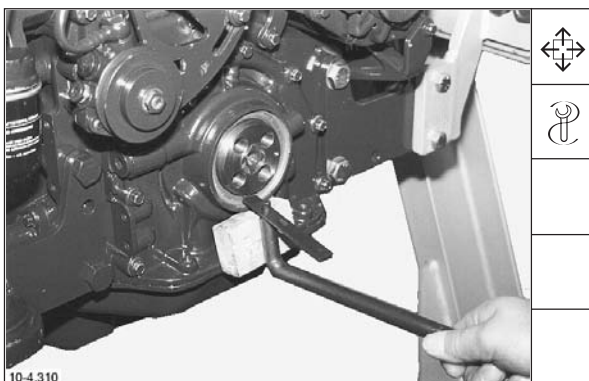
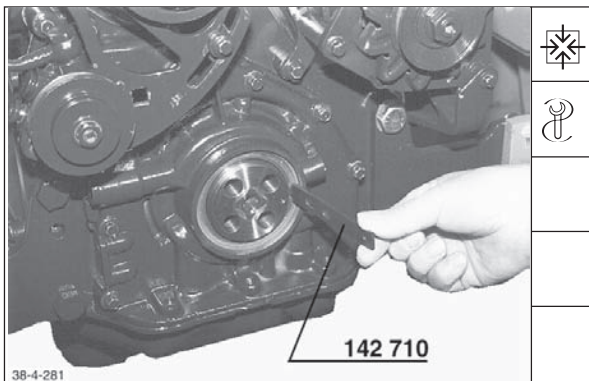
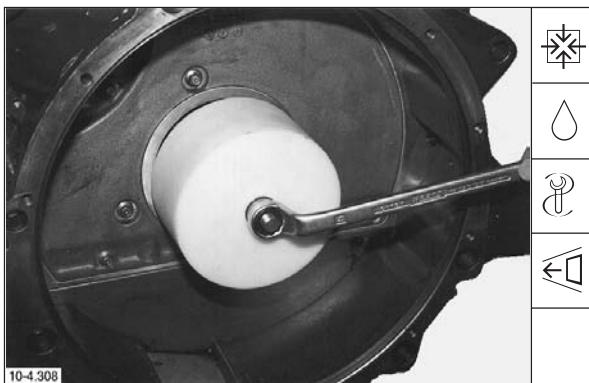
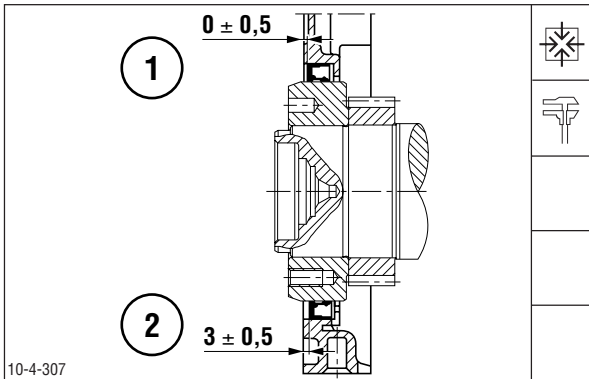

Deutsch

4. Einbautiefe beachten.

Pos.1 Einbautiefe Erstmontage  
Pos. 2 Maximale Einbautiefe

4.1 Dichtlippen einölen. Wellendichtring mit Eindrückvorrichtung montieren. Dichtlippe weist zur Kurbelwelle.

**- Vorderer Deckel -**

Keilriemenscheibe ist abgebaut.

1. Abziehhaken in den Wellendichtring eindrücken.

2. Wellendichtring mit Ausziehhaken aus dem vorderen Deckel hebeln.

**Demontage und Montage, Motor komplett**  
**Disassembly and reassembly of complete engine**  
**Démontage et montage moteur complet**  
**Smontaggio e rimontaggio completo del motore**

English	Français	Italiano
<p>4. Pay attention to the installation depth.</p> <p>Item 1 installation depth initial assembly  Item 2 maximum installation depth</p>	<p>4. Tenir compte de la profondeur de montage</p> <p>Rep. 1 Profondeur de montage première monte  Rep. 1 Profondeur de montage maximale</p>	<p>4. Tenere conto della profondità d'installazione.</p> <p>Pos. 1 Profondità d'installazione al primo montaggio  Pos. 2 Massima profondità d'installazione</p>
<p>4.1 Oil sealing lips. Fit shaft seal with assembly tool. Sealing lip faces crankshaft.</p>	<p>4.1 Huiler les lèvres d'étanchéité. Monter le joint d'arbre à l'aide du dispositif d'insertion. La lèvre d'étanchéité est dirigée vers le vilebrequin.</p>	<p>4.1. Oliare i labbri di tenuta. Montare l'anello paraolio servendosi dell'apposito dispositivo d'inserzione. Il labbro di tenuta deve essere rivolto verso l'albero a gomiti.</p>
<p><b>- Front cover -</b></p> <p>V-belt pulley has been removed.</p>	<p><b>- Couvercle AV -</b></p> <p>La poulie à gorge a été déposée.</p>	<p><b>- Coperchio anteriore -</b></p> <p>La puleggia della cinghia trapezoidale è smontata.</p>
<p>1. Press extractor into shaft seal.</p>	<p>1. Introduire le crochet extracteur dans le joint d'arbre.</p>	<p>1. Introdurre nell'anello paraolio il gancio dell'estrattore.</p>
<p>2. Lift shaft seal with extractor out of front cover.</p>	<p>2. A l'aide du crochet extracteur dégager et retirer le joint d'arbre du couvercle avant.</p>	<p>2. Servendosi della leva dell'estrattore, estrarre l'anello paraolio dal coperchio anteriore</p>

**Demontage und Montage, Motor komplett**  
**Disassembly and reassembly of complete engine**  
**Démontage et montage moteur complet**  
**Smontaggio e rimontaggio completo del motore**

English	Français	Italiano
3. Fit guide sleeve.	3. Monter la douille de guidage.	3. Montare la bussola di guida.
<p>4. Pay attention to the installation depth.</p> <p>Item 1 installation depth initial assembly  Item 2 maximum installation depth</p>	<p>4. Tenir compte de la profondeur de montage</p> <p>Rep. 1 Profondeur de montage première monte  Rep. 1 Profondeur de montage maximale</p>	<p>4. Tenere conto della profondità d'installazione.</p> <p>Pos. 1 Profondità d'installazione al primo montaggio  Pos. 2 Massima profondità d'installazione</p>
4.1 Oil sealing lips. Fit shaft seal with assembly tool. Sealing lip faces crankshaft.	<p>4.1 Huiler les lèvres d'étanchéité.  Monter le joint d'arbre à l'aide du dispositif d'insertion. La lèvre d'étanchéité est dirigée vers le vilebrequin.</p>	<p>4.1. Oliare i labbri di tenuta.  Montare l'anello paraolio servendosi dell'apposito dispositivo d'inserzione.  Il labbro di tenuta deve essere rivolto verso l'albero a gomiti.</p>

Deutsch

Werkstatthandbuch BFM 1012/E, BFM 1013/E

3. Führungsbuchse anbauen.

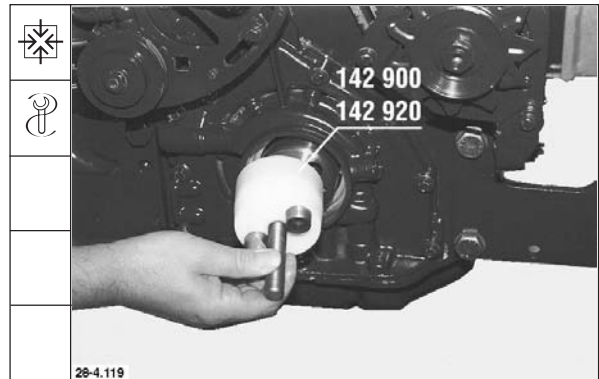

4. Einbautiefe beachten.

- Pos. 1 Einbautiefe Erstmontage
- Pos. 2 Maximale Einbautiefe

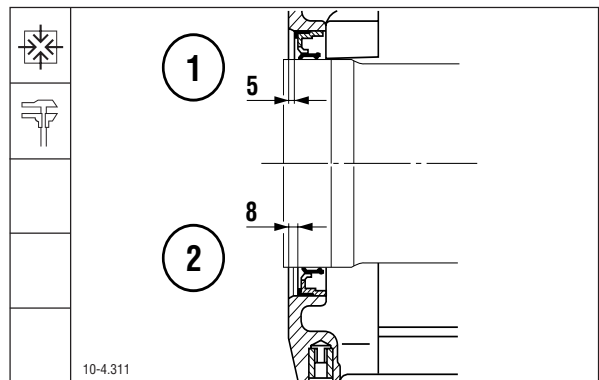

4.1 Dichtlippen einölen. Wellendichtring mit Eindrückvorrichtung montieren. Dichtlippe weist zur Kurbelwelle.

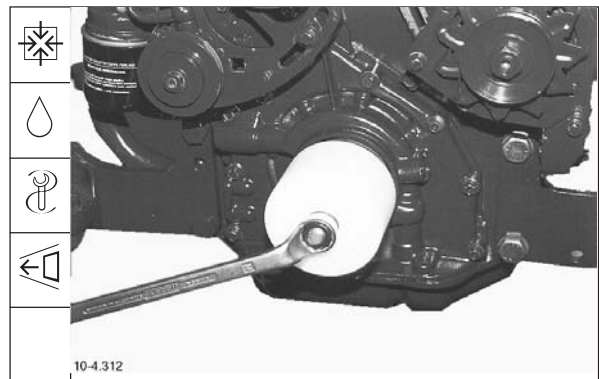

**Demontage und Montage, Motor komplett**  
**Disassembly and reassembly of complete engine**  
**Démontage et montage moteur complet**  
**Smontaggio e rimontaggio completo del motore**

---

**Demontage und Montage, Motor komplett**  
**Disassembly and reassembly of complete engine**  
**Démontage et montage moteur complet**  
**Smontaggio e rimontaggio completo del motore**

---

**Demontage und Montage, Motor komplett**  
**Disassembly and reassembly of complete engine**  
**Démontage et montage moteur complet**  
**Smontaggio e rimontaggio completo del motore**

English	Français	Italiano
<p><b>Removing and refitting air compressor</b></p> <p>1. Remove air compressor and oil pressure pipes.</p> <p><b>Note:</b> Inspect all single parts and replace if necessary.</p> <p>2. Fit new O-seal.</p> <p>3. Fit oil pressure pipe together with new Cu seals prior to mounting air compressor.</p> <p><b>Note:</b> Do not yet tighten banjo bolt.</p> <p>4. Mount air compressor. Insert bolts with locking compound <b>Deutz DW 72</b> and tighten with a torque of <b>61 ± 6 Nm</b>.</p>	<p><b>Pose et dépose du compresseur à air</b></p> <p>1. Déposer le compresseur à air et les conduites de refoulement d'huile.</p> <p><b>Nota:</b> contrôler visuellement toutes les pièces, les changer le cas échéant.</p> <p>2. Monter un joint torique neuf.</p> <p>3. Monter la conduite de refoulement d'huile avec des joints neufs en Cu avant de mettre en place le compresseur à air.</p> <p><b>Nota:</b> ne pas encore serrer la vis creuse.</p> <p>4. Monter le compresseur. Monter les vis avec de la pâte de sécurité <b>Deutz DW 72</b> puis serrer au couple de <b>61 ± 6 Nm</b>.</p>	<p>Smontaggio e montaggio del compressore d'aria.</p> <p>1. Smontare il compressore d'aria e le tubazioni di mandata dell'olio.</p> <p><b>Nota:</b> Controllare tutti i particolari e sostituirli qualora necessario.</p> <p>2. Montare un nuovo O-ring.</p> <p>3. Montare la tubazione di mandata dell'olio con nuove guarnizioni di rame prima di rimontare il compressore dell'aria.</p> <p><b>Nota:</b> Non serrare ancora le viti</p> <p>4. Montare il compressore d'aria. Dopo averle spalmate con ermetico <b>Deutz DW 72</b>, inserire le viti e serrarle con una coppia di <b>61 ± 6 Nm</b>.</p>



Deutsch

Werkstatthandbuch BFM 1012/E, BFM 1013/E

Luftpresser ab- und anbauen.

1. Luftpresser und Öldruckleitungen abbauen.

**Hinweis:** Alle Teile sichtprüfen, ggf. austauschen.

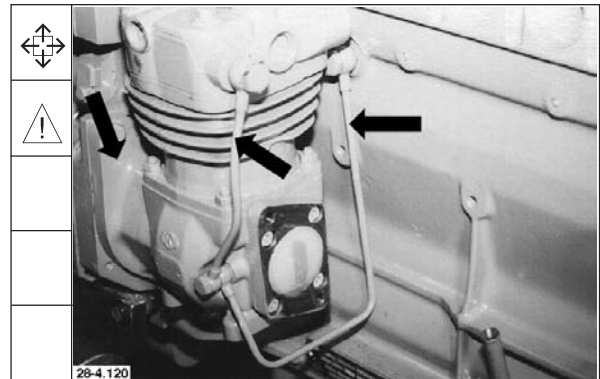

2. Neuen Runddichtring montieren.

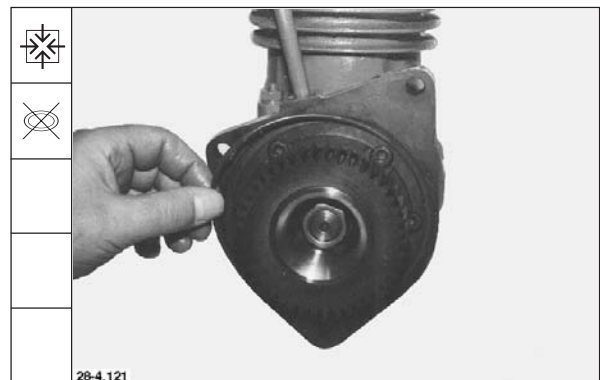

3. Öldruckleitung mit neuen Cu-Dichtungen vor Luftpresseranbau montieren.

**Hinweis:** Noch nicht festdrehen.



4. Luftpresser anbauen.  
Schrauben mit Sicherungsmittel **Deutz DW 72** einsetzen und mit einem Drehmoment von **61 ± 6 Nm** festdrehen.



**Demontage und Montage, Motor komplett**  
**Disassembly and reassembly of complete engine**  
**Démontage et montage moteur complet**  
**Smontaggio e rimontaggio completo del motore**

Werkstatthandbuch BFM 1012/E, BFM 1013/E

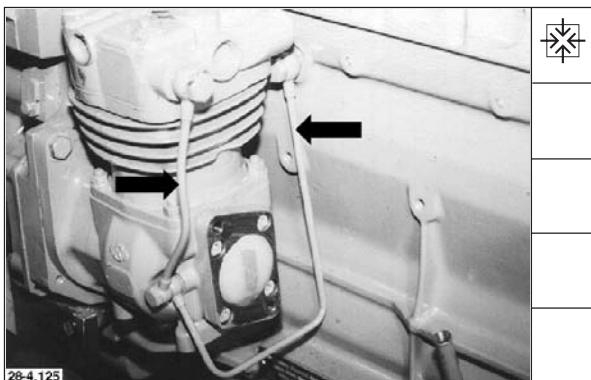
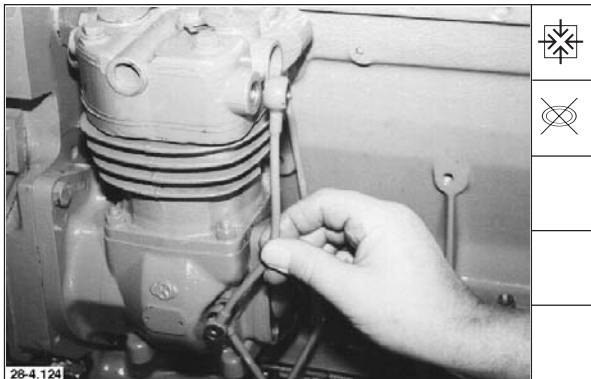

**Deutsch**

5. Zweite Öldruckleitung mit neuen Cu-Dichtungen anbauen.

6. Öldruckleitungen am Kurbelgehäuse und Luftpresser festdrehen.

**Demontage und Montage, Motor komplett**  
**Disassembly and reassembly of complete engine**  
**Démontage et montage moteur complet**  
**Smontaggio e rimontaggio completo del motore**

English	Français	Italiano
5. Fit 2nd oil pressure pipe with new Cu seals.	5. Monter la 2 <sup>ème</sup> conduite de refoulement d'huile avec des joints en Cu neufs.	5. Montare la seconda tubazione di mandata dell'olio con nuove guarnizioni di rame.
6. Secure oil pressure pipes on crankcase and air compressor.	6. Serrer les conduites du refoulement d'huile et le compresseur à air.	6. Serrare sull'incastellatura le viti delle tubazioni di mandata dell'olio, nonché quelle del compressore d'aria.

**Demontage und Montage, Motor komplett**  
**Disassembly and reassembly of complete engine**  
**Démontage et montage moteur complet**  
**Smontaggio e rimontaggio completo del motore**

English	Français	Italiano
<b>Removing and refitting power steering pump</b>	<b>Pose et dépose de la pompe direction auxiliaire</b>	<b>Smontaggio e montaggio della pompa del servosterzo.</b>
1. Fit power steering pump. Take off driver disc.	1. Dé poser la pompe de direction auxiliaire. Retirer le disque entraînement.	1. Smontaggio del disco di trascinamento.
<b>Note:</b> Inspect all single parts and replace if necessary.	<b>Nota:</b> contrôler visuellement toutes les pièces, les changer le cas échéant,	<b>Nota:</b> Controllare tutte le parti, sostituendole qualora necessario.
2. Fit driver disc.	2. Monter le disque entraînement.	2. Montare il disco di trascinamento.
3. Fit new O-seal and apply dehydrated lubricant.	3. Monter un joint torique neuf et lénduire de lubrifiant anhydre.	3. Montare un nuovo O-ring e spalmarci un lubrificante anidro.
4. Fit power steering pump and make sure that drivers engage in driver disc.	4. Monter la pompe de direction auxiliaire. Veiller á ce que les tocs soient bien en prise dans les disques entraînement.	4. Montare la pompa del servosterzo. Controllare che i trascinatori ingrano nel disco di trascinamento.

Deutsch

Werkstatthandbuch BFM 1012/E, BFM 1013/E

Lenkhilfspumpe ab- und anbauen.

1. Lenkhilfspumpe abbauen. Mitnehmerscheibe abnehmen.

**Hinweis:** Alle Teile sichtprüfen, ggf. austauschen.



2. Mitnehmerscheibe einbauen.



3. Neuen Runddichtring montieren und mit wasserfreiem Schmiermittel bestreichen.



4. Lenkhilfspumpe anbauen. Darauf achten, daß die Mitnehmer in die Mitnehmerscheibe greifen.

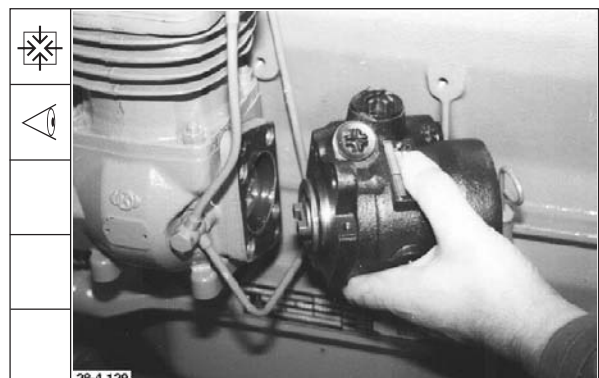

**Demontage und Montage, Motor komplett**  
**Disassembly and reassembly of complete engine**  
**Démontage et montage moteur complet**  
**Smontaggio e rimontaggio completo del motore**

Werkstatthandbuch BFM 1012/E, BFM 1013/E



Deutsch

- Schrauben mit einem Drehmoment von **43,5 ± 4 Nm** festdrehen.

**Hinweis:** Auf Spezielscheiben achten.

**Demontage und Montage, Motor komplett**  
**Disassembly and reassembly of complete engine**  
**Démontage et montage moteur complet**  
**Smontaggio e rimontaggio completo del motore**

English	Français	Italiano
5. Tighten bolts with a torque of <b>43.5 ± 4 Nm.</b> <b>Note:</b> Watch out for special washers.	5. Serrer les vis au couple de <b>43.5 ± 4 Nm.</b> <b>Nota:</b> veiller aux cales spéciales.	5. Serrare le viti con una coppia di <b>43,5 ± 4 Nm.</b> <b>Nota:</b> Maneggiare con cautela i dischi speciali.

**Demontage und Montage, Motor komplett**  
**Disassembly and reassembly of complete engine**  
**Démontage et montage moteur complet**  
**Smontaggio e rimontaggio completo del motore**

English	Français	Italiano
<p><b>Removing and refitting hydraulic pump</b></p> <ol style="list-style-type: none"> <li>1. Unscrew bolts from hydraulic pump.</li> <li>2. Unscrew bolts from guide flange. Remove hydraulic pump complete with guide flange.</li> </ol> <p><b>Note:</b> Inspect all single parts and replace if necessary.</p> <ol style="list-style-type: none"> <li>3. Mount preassembled hydraulic pump together with guide flange. Tighten guide flange bolts with a torque of <b>21 ± 2 Nm</b>.</li> </ol> <p><b>Note:</b> Apply dehydrated lubricant to seal/receiving bore.</p> <ol style="list-style-type: none"> <li>4. Move gasket into installation position. Tighten hydraulic pump bolts with a torque of <b>50 ± 10 Nm</b>.</li> </ol>	<p><b>Pose et dépose de la pompe hydraulique</b></p> <ol style="list-style-type: none"> <li>1. Dévisser puis retirer les vis de la pompe hydraulique.</li> <li>2. Devisser puis retirer les vis de la bride de guidage. Retirer entièrement la pompe hydraulique avec la bride de guidage.</li> </ol> <p><b>Nota:</b> enduire visuellement toutes les pièces, les changer le cas échéant.</p> <ol style="list-style-type: none"> <li>3. Monter la pompe hydraulique préassemblée avec la bride de guidage. Serrer les vis de la bride de guidage au couple de <b>21 ± 2 Nm</b>.</li> </ol> <p><b>Nota:</b> enduire el joint torique et l'alésager du legement de lubrifiant anhydre.</p> <ol style="list-style-type: none"> <li>4. Insérer el joint en position de montage. Serrer les vis de la pompe hydraulique au couple de <b>50 ± 10 Nm</b>.</li> </ol>	<p><b>Smontaggio e montaggio della pompa idraulica.</b></p> <ol style="list-style-type: none"> <li>1. Svitare e togliere le viti della pompa idraulica.</li> <li>2. Svitare e togliere le viti della flangia di guida. Smontare la pompa idraulica assieme alla flangia di guida.</li> </ol> <p><b>Nota:</b> Controllare tutte le parti e sostituirle qualora necessario.</p> <ol style="list-style-type: none"> <li>3. Montare la pompa idraulica preassemblata assieme alla sua flangia di guida. Serrare le viti della flangia di guida con una coppia di <b>21 ± 2 Nm</b>.</li> </ol> <p><b>Nota:</b> Spalmare un lubrificante anidro su O-ring e foro d'alloggiamento.</p> <ol style="list-style-type: none"> <li>4. Infilare la guarnizione nella sua posizione di montaggio. Serrare le viti della pompa idraulica con una coppia di <b>50 ± 10 Nm</b>.</li> </ol>



Deutsch

Werkstatthandbuch BFM 1012/E, BFM 1013/E

Hydraulikpumpe ab- und anbauen.

1. Schrauben von Hydraulikpumpe heraus-schrauben.

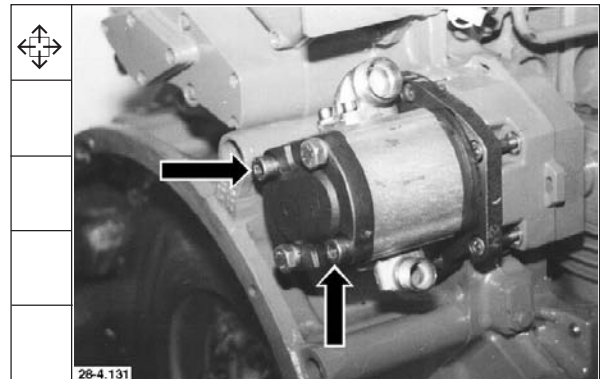

2. Schrauben von Führungsflansch heraus-schrauben.  
Hydraulikpumpe komplett mit Führungs-flansch abnehmen.

**Hinweis:** Alle Teile sichtprüfen, ggf. austau-schen.

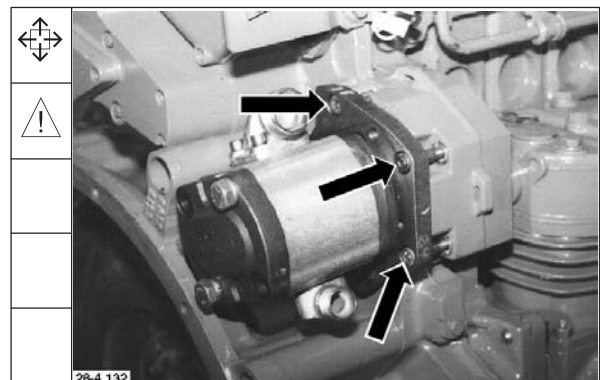

3. Vormontierte Hydraulikpumpe mit Führungsflansch anbauen.  
Schrauben von Führungsflansch mit einem Drehmoment von  $21 \pm 2 \text{ Nm}$  festdrehen.

**Hinweis:** Runddichtring/Aufnahmebohrung mit wasserfreiem Schmiermittel be-streichen.

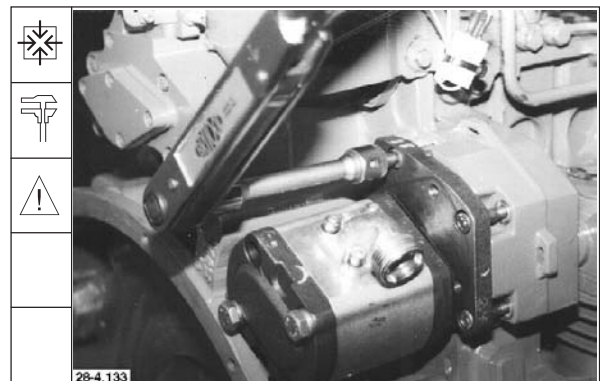

4. Dichtung in Einbaulage schieben. Schrau-ben von Hydraulikpumpe mit einem Dreh-moment von  $50 \pm 10 \text{ Nm}$  festdrehen.



**Demontage und Montage, Motor komplett**  
**Disassembly and reassembly of complete engine**  
**Démontage et montage moteur complet**  
**Smontaggio e rimontaggio completo del motore**

---

**Demontage und Montage, Motor komplett**  
**Disassembly and reassembly of complete engine**  
**Démontage et montage moteur complet**  
**Smontaggio e rimontaggio completo del motore**

---

**Demontage und Montage, Motor komplett**  
**Disassembly and reassembly of complete engine**  
**Démontage et montage moteur complet**  
**Smontaggio e rimontaggio completo del motore**

English	Français	Italiano
<p><b>Removing and refitting hydraulic pump together with bracket</b></p> <ol style="list-style-type: none"><li>1. Remove oil pressure pipe</li>       <li>2. Remove hydraulic pump.</li>       <li>3. Remove bracket.</li></ol> <p><b>Note:</b> Inspect all single parts and replace if necessary. Renew gaskets. Check bore in hollow shaft and drive shaft for free passage.</p>       <li>4. Fit preassembled bracket.</li> <p><b>Note:</b> Lightly oil O-seal/bore.</p>	<p><b>Poset et dépose de la pompe hydraulique</b></p> <ol style="list-style-type: none"><li>1. Monter conduite de refoulement d'huile.</li>       <li>2. Déposer la pompe hydraulique.</li>       <li>3. Déposer la console.</li></ol> <p><b>Nota:</b> effectuer un contrôle visuel de toutes les pièces, au besoin les remplacer. Renouveler les joints. Contrôler le libre passage de l'alésage de l'arbre creux d'entraînement.</p>       <li>4. Monter la console préassemblée.</li> <p><b>Nota:</b> huiler légèrement le joint torique/l'alésage.</p>	<p><b>Smontaggio e montaggio della pompa idraulica con mensola</b></p> <ol style="list-style-type: none"><li>1. Smontare la tubazione di mandata dell'olio.</li>       <li>2. Smontare la pompa idraulica.</li>       <li>3. Smontare la mensola.</li></ol> <p><b>Nota:</b> Controllare tutte le parti, sostituendole qualora necessario. Sostituire le guarnizioni. Controllare che sia il foro nell'albero cavo che quello nell'albero di comando siano liberi.</p>       <li>4. Montare la mensola preassemblata.</li> <p><b>Nota:</b> Oliare leggermente l'O-ring ed il foro.</p>

Deutsch

Werkstatthandbuch BFM 1012/E, BFM 1013/E

Hydraulikpumpe mit Konsole ab- und anbauen

1. Öldruckleitung abbauen.

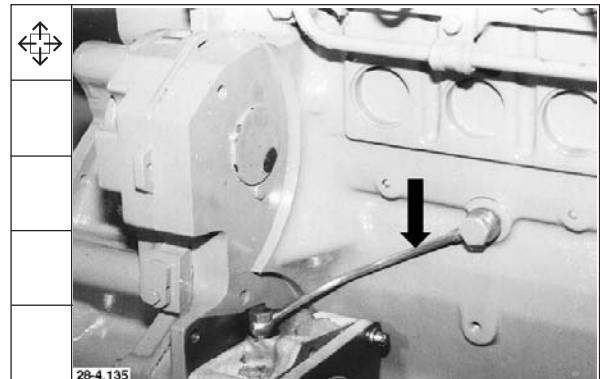

2. Hydraulikpumpe abbauen.

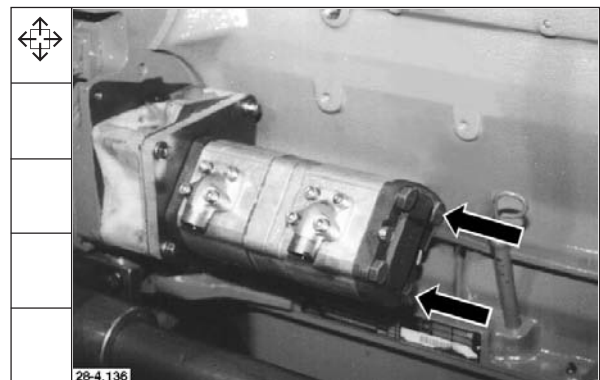

3. Konsole abbauen.

**Hinweis:** Alle Teile sichtprüfen, ggf. austauschen. Dichtungen erneuern. Bohrung in Hohl- und Mitnehmerwelle auf freien Durchgang prüfen.

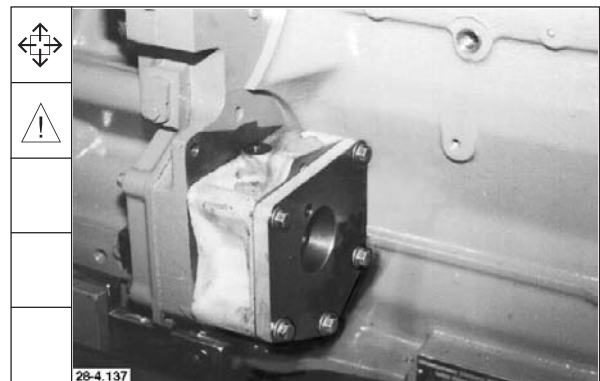

4. Vormontierte Konsole anbauen.

**Hinweis:** Runddichtring/Bohrung leicht einölen.

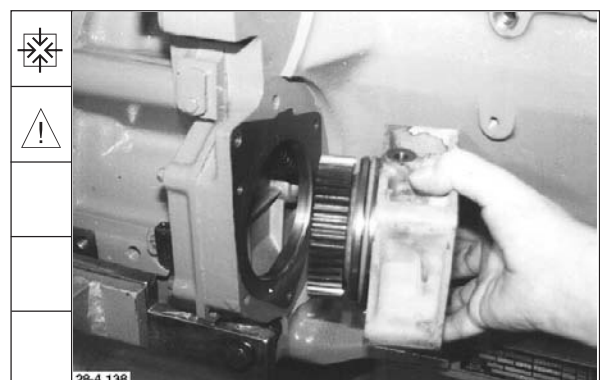

**Demontage und Montage, Motor komplett**  
**Disassembly and reassembly of complete engine**  
**Démontage et montage moteur complet**  
**Smontaggio e rimontaggio completo del motore**

Werkstatthandbuch BFM 1012/E, BFM 1013/E

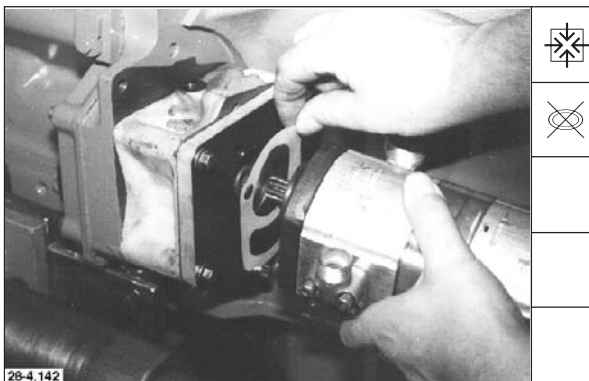
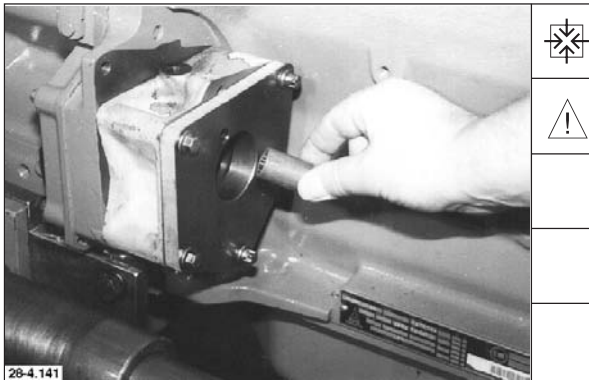
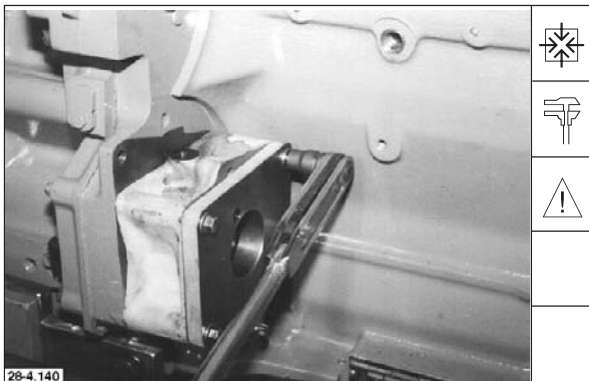
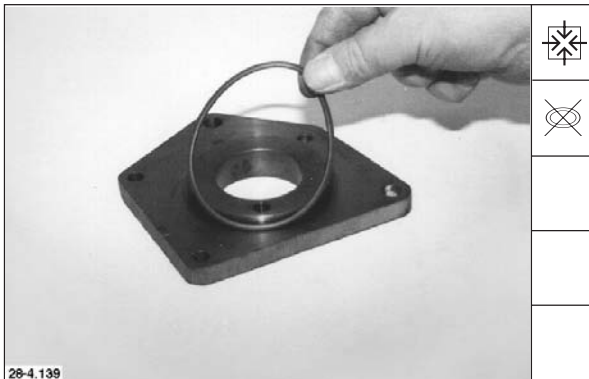

**Deutsch**

5. Neuen Runddichtring auf Befestigungsflansch auflegen.

6. Befestigungsflansch anbauen.  
 Schrauben nach Anziehvorschrift festdrehen.  
 Schrauben M 8 = **21 ± 2 Nm**  
 Schrauben M 10 = **40,5 ± 4 Nm**

**Hinweis:** Schrauben M10 sind mikrokapselt. Eine Wiederverwendung ist nicht zulässig.

7. Führungshülse einsetzen.

**Hinweis:** Auf Sicherungsring in der Mitte der Führungshülse achten.

8. Neue Dichtung auflegen. Hydraulikpumpe anbauen.

**Demontage und Montage, Motor komplett**  
**Disassembly and reassembly of complete engine**  
**Démontage et montage moteur complet**  
**Smontaggio e rimontaggio completo del motore**

English	Français	Italiano
<p>5. Position new O-seal on fastening flange.</p>	<p>5. Placer un joint torique neuf sur la bride de fixation.</p>	<p>5. Montare un nuovo O-ring sulla flangia di sostegno.</p>
<p>6. Fit fastening flange. Tighten bolts according to specification.</p> <p>Bolts M 8 = <b>21 ± 2 Nm</b>            Bolts M 10 = <b>40.5 ± 4 Nm</b></p> <p><b>Note:</b> Bolts M10 are micro-encapsulated. Their re-use is not permissible.</p>	<p>6. Monter la bride de fixation. Serrer les vis selon les préconisations de serrage</p> <p>vis M 8 = <b>21 ± 2 Nm</b>            vis M 10 = <b>40,5 ± 4 Nm</b></p> <p><b>Nota:</b> les vis M10 sont dotées d'une microcapsule.</p>	<p>6. Montare la flangia di sostegno. Serrare le viti in base alle prescrizioni.</p> <p>Viti M 8 = <b>21 ± 2 Nm</b>            Viti M 10 = <b>40,5 ± 4 Nm</b></p> <p><b>Nota:</b> Prestare attenzione all'anello di sicurezza nel mezzo della bussola di guida.</p>
<p>7. Insert guide bush.</p> <p><b>Note:</b> Watch out for circlip in the middle of guide bush.</p>	<p>7. Mettre en place la douille de guidage.</p> <p><b>Nota:</b> veiller à ce que le circlip soit au milieu de la douille de guidage.</p>	<p>7. Inserire la bussola di guida</p> <p><b>Nota:</b> Fare attenzione all'anello di sicurezza nella parte mediana della bussola di guida.</p>
<p>8. Position new gasket. Mount hydraulic pump.</p>	<p>8. Placer un joint neuf puis monter la pompe.</p>	<p>8. Montare una nuova guarnizione. Montare la pompa idraulica.</p>

**Demontage und Montage, Motor komplett**  
**Disassembly and reassembly of complete engine**  
**Démontage et montage moteur complet**  
**Smontaggio e rimontaggio completo del motore**

English	Français	Italiano
9. Tighten bolts with a torque of <b>50 ± 10 Nm.</b>	9. Serrer les vis au couple de <b>50 ± 10 Nm.</b>	9. Serrare le viti con una coppia di <b>50 ± 10 Nm.</b>
10. Fit oil pressure pipe with new Cu seals.	10. Monter la conduite du refoulement d'huile avec des joints Cu neufs.	10. Montare la tubazione di mandata dell'olio con nuove guarnizioni di rame.



**Deutsch**

**Werkstatthandbuch BFM 1012/E, BFM 1013/E**

9. Schrauben mit einem Drehmoment von **50 ± 10 Nm** festdrehen.



28-4.143

10. Öldruckleitung mit neuen Cu-Dichtungen anbauen.

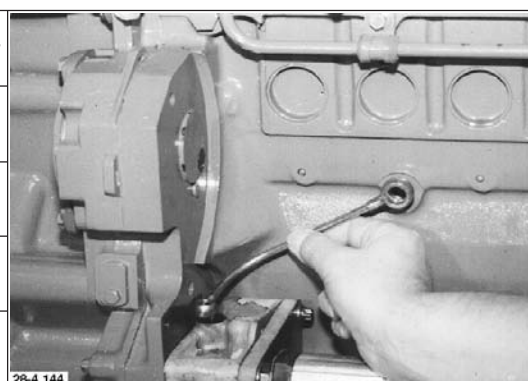

28-4.144

**Demontage und Montage, Motor komplett**  
**Disassembly and reassembly of complete engine**  
**Démontage et montage moteur complet**  
**Smontaggio e rimontaggio completo del motore**

---

**Demontage und Montage, Motor komplett**  
**Disassembly and reassembly of complete engine**  
**Démontage et montage moteur complet**  
**Smontaggio e rimontaggio completo del motore**

---

**Demontage und Montage, Motor komplett**  
**Disassembly and reassembly of complete engine**  
**Démontage et montage moteur complet**  
**Smontaggio e rimontaggio completo del motore**

English	Français	Italiano
<p><b>Replacing injection pump in case of service</b></p>	<p><b>Remplacement de la pompe d'injection en SAV</b></p>	<p><b>Sostituzione delle pompe d'iniezione nel caso di Service</b></p>
<p>This repair method only refers to the replacement of injection pumps. If other components are to be replaced as well, e.g. roller tappets, governor, etc., proceed according to chapter 4 „Installing injection pump“.</p>	<p>La présente méthode de réparation ne concerne que le remplacement des pompes d'injection. En cas de remplacement supplémentaire d'autres pièces comme p. ex. les poussoirs à galet, le régulateur etc. procéder comme au chapitre 4 „montage pompes d'injection“.</p>	<p>Tale metodo di riparazione riguarda soltanto la sostituzione delle pompe d'iniezione. Se devono però venire sostituite anche altre parti, come per esempio punterie a rullo, regolatore, ecc. la procedura rimane quella illustrata nel capitolo 4 “Installazione delle pompe di iniezione”.</p>
<p><b>Special tool required:</b>            Press-on device for control rod _____ 100 830            Extracting device _____ 150 800            Extractor for injector _____ 110 030</p>	<p><b>Outillage spécial:</b>            Dispositif de montage de crémaillère _____ 100 830            Extrateur _____ 150 800            Extrateur pour injecteur _____ 110 030</p>	<p><b>Attrezzi speciali:</b>            Dispositivo di spinta per l'asta a cremagliera _____ 100 830            Dispositivo d'estrazione _____ 150 800            Estrattore per l'iniettore _____ 110 030</p>
<p>1. Remove crankcase breather and cylinder head cover.</p>	<p>1. Déposer l'évent de carter et le cache-culbuteurs.</p>	<p>1. Smontare lo sfiato dell'incastellatura ed il coperchio delle punterie.</p>
<p>2. Pull off cable plug. Remove shutdown solenoid or screw plug.</p>	<p>2. Retirer le contacteur de câble. Déposer l'électroaimant d'arrêt ou le bouchon de fermeture.</p>	<p>2. Staccare lo spinotto dei cavi. Smontare l'elettromagnete d'arresto oppure il tappo.</p>
<p>3. Press control rod with shutdown lever into stop position. Insert press-on device and screw on.</p>	<p>3. A l'aide du levier d'arrêt pousser la crémaillère en position de stop. Monter l'outil de montage et serrer.</p>	<p>3. Per mezzo della leva d'arresto spingere l'asta a cremagliera nella posizione di stop. Posizionare il dispositivo di spinta e fissarlo.</p>

**Deutsch**

**Werkstatthandbuch BFM 1012/E, BFM 1013/E**

**Austausch der Einspritzpumpe im Servicefall**

Diese Reparaturmethode ist nur für den Austausch der Einspritzpumpen gedacht. Sollten zusätzlich noch andere Teile getauscht werden, z.B. Rollenstößel, Regler etc., ist wie in Kapitel 4 „Einspritzpumpen Einbau“ zu verfahren.

**Spezialwerkzeug:**

Andrückvorrichtung für

Regelstange \_\_\_\_\_ 100 830

Ausziehvorrichtung \_\_\_\_\_ 150 800

Auszieher für Einspritzventil \_\_\_\_\_ 110 030

1. Kurbelgehäuseentlüftung und Zylinderkopfhaube abbauen.

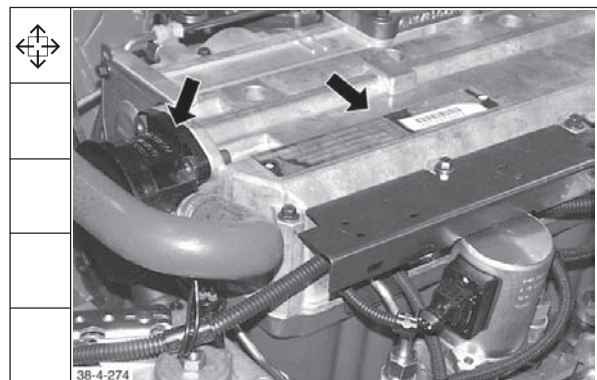

2. Kabelstecker abziehen.  
Abstellmagnet oder Verschlussstopfen ausbauen.

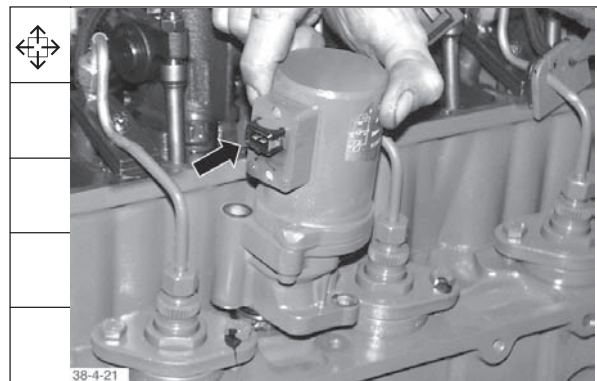

3. Regelstange mittels Abstellhebel in Stopstellung drücken. Andrückvorrichtung einsetzen und verschrauben.

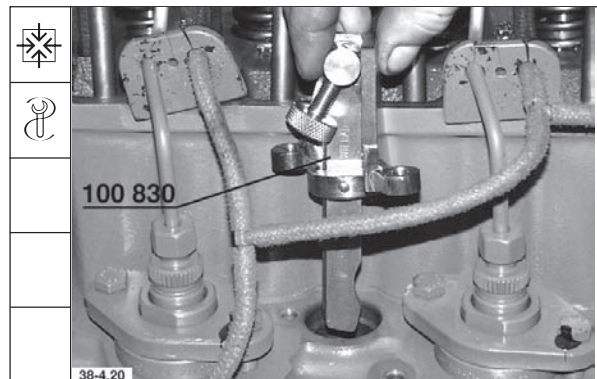

# Demontage und Montage, Motor komplett

## Disassembly and reassembly of complete engine

### Démontage et montage moteur complet

### Smontaggio e rimontaggio completo del motore

Werkstatthandbuch BFM 1012/E, BFM 1013/E

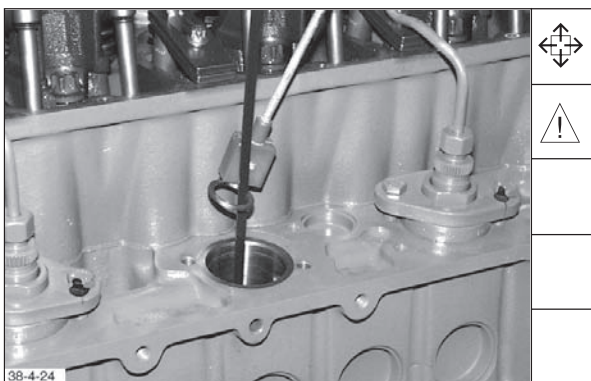
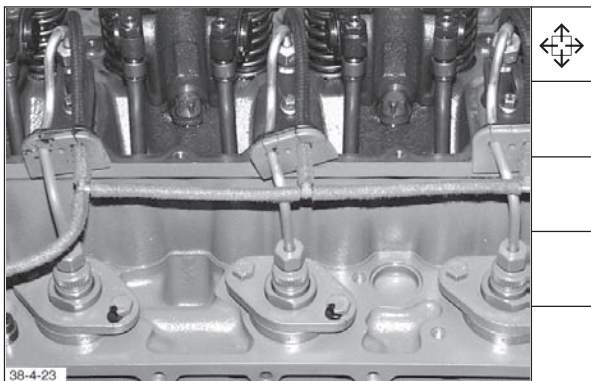
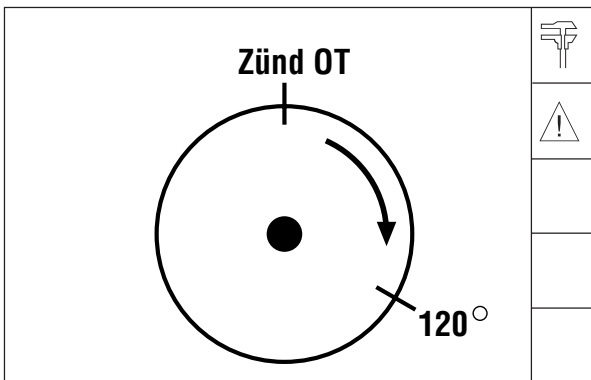
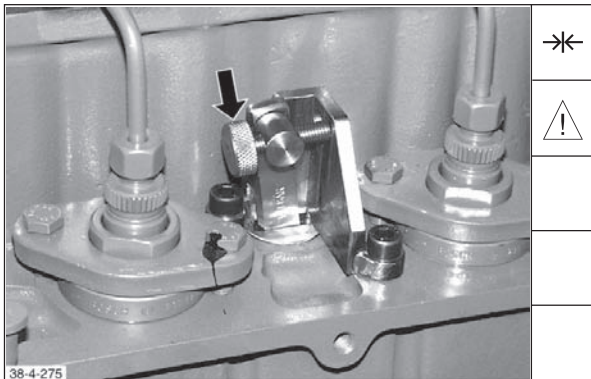

#### Deutsch

4. Regelstange mit Rändel-Feststellschraube in Stopstellung drücken.

**Hinweis:** Rändel-Feststellschraube von Hand festdrehen.

5. Zylinder der auszubauenden Einspritzpumpe auf Zünd-O.T. stellen.  
Kurbelwelle ca. **120°** entgegen der Motordrehrichtung drehen.

**Hinweis:** Darstellung Blickrichtung auf Schwungrad.

6. Einspritzleitung und Einspritzpumpe abbauen.

7. Ausgleichsscheibe mit Stabmagnet vorsichtig herausnehmen.

**Hinweis:** Neue Ausgleichsscheibe ermitteln, siehe für BFM 1012 Seite 1.00.15 für BFM 1013 Seite 1.00.17

**Demontage und Montage, Motor komplett**  
**Disassembly and reassembly of complete engine**  
**Démontage et montage moteur complet**  
**Smontaggio e rimontaggio completo del motore**

English	Français	Italiano
<p>4. Press control rod with knurled-head setscrew into stop position.</p> <p><b>Note:</b> Tighten knurled-head setscrew by hand.</p>	<p>4. A l'aide de la vis de blocage moletée amener la crémaillère en position de stop.</p> <p><b>Nota:</b> serrer la vis de blocage moletée à la main.</p>	<p>4. Per mezzo della vite d'arresto a testa zigrinata trattenere l'asta a cremagliera nella posizione di stop.</p> <p><b>Nota:</b> Bloccare a mano la vite d'arresto a testa zigrinata.</p>
<p>5. Move cylinder of injection pump to be removed to firing TDC. Turn crankshaft about <b>120°</b> against direction of engine rotation.</p> <p><b>Note:</b> Flywheel is faced on the illustration at the left.</p>	<p>5. Placer le cylindre de la pompe d'injection à déposer en position d'allumage PMH. Virer le vilebrequin d'environ <b>120°</b> dans le sens opposé au sens de rotation du moteur.</p> <p><b>Nota:</b> illustration observateur regardant le volant moteur.</p>	<p>5. Posizionare sul PMS d'accensione il cilindro corrispondente alla pompa d'iniezione da smontare. Virare l'albero a gomiti di circa <b>120°</b> in senso contrario al senso di rotazione del motore.</p> <p><b>Nota:</b> Nello schizzo una vista guardando il volano.</p>
<p>6. Remove injection line and injection pump.</p>	<p>6. Déposer la conduite d'injection et la pompe d'injection.</p>	<p>6. Smontare la tubazione d'iniezione e la pompa d'iniezione.</p>
<p>7. Carefully take out shim using bar magnet.</p> <p><b>Note:</b> Determine new shim, see page 1.00.15 for BFM 1012, page 1.00.17 for BFM 1013.</p>	<p>7. Retirer avec précaution la rondelle d'épaisseur à l'aide d'une barre magnétique.</p> <p><b>Nota:</b> calcul de l'épaisseur de la rondelle, voir page 1.00.15 pour le BFM 1012 et page 1.00.17 pour le BFM 1013</p>	<p>7. Estrarre con cautela la rondella di spessore per mezzo di una sbarretta magnetizzata.</p> <p><b>Nota:</b> Estrapolare lo spessore della nuova rondella di spessore, Vedi per BFM 1012 pagina 1.00.15 e per BFM 1013 pagina 1.00.17</p>

**Demontage und Montage, Motor komplett**  
**Disassembly and reassembly of complete engine**  
**Démontage et montage moteur complet**  
**Smontaggio e rimontaggio completo del motore**

English	Français	Italiano
<p>8. Position new shim previously determined on roller tappet.</p> <p><b>Note:</b> See page 4.00.37 items 78 - 84 for installation of injection pump.</p>	<p>8. Placer la rondelle d'épaisseur nouvellement calculée sur le poussoir à galet.</p> <p><b>Nota:</b> montage pompe d'injection voir page 4.00.37 à partir des pts 78 - 84.</p>	<p>8. Collocare la nuova rondella di spessore sulla punteria a rullo.</p> <p><b>Nota:</b> Circa il montaggio della pompa d'iniezione vedi dalla pag. 4.00.37, pos. 78-84</p>
<p>9. Remove injector.</p> <p><b>Note:</b> If jammed, use extracting device No. 150 800 together with extractor No. 110 030.</p> <p>See page 4.00.48 from items 114 for fitting injector and injection line.</p>	<p>9. Déposer l'injecteur.</p> <p><b>Nota:</b> si les pièces sont bloquées utiliser d'extraction No. 150 800 avec l'extracteur No. 110 030.</p> <p>Monter l'injecteur et la conduite voir page 4.00.48 pt. 114.</p>	<p>9. Smontare l'iniettore.</p> <p><b>Nota:</b> Se l'iniettore è incollato, far uso del dispositivo d'estrazione nr. 150 800 con l'estrattore nr. 110 030</p> <p>Montare l'iniettore e la tubazione d'iniezione, vedi pag. 4.00.48 dalla pos. 114.</p>
<p>10. Turn back knurled-head setscrew. Remove press-on device.</p> <p><b>Note:</b> Check whether control rod moves easily from stop to start position. For this purpose actuate shutdown lever of governor.</p>	<p>10. Dévisser la vis de blocage moletée puis déposer l'outil de montage.</p> <p><b>Nota:</b> vérifier si la crémaillère coulisse librement de la position stop à la position de démarrage. Pour cela actionner le levier d'arrêt du régulateur.</p>	<p>10. Svitare la vite d'arresto a testa zigrinata. Smontare il dispositivo di spinta.</p> <p><b>Nota:</b> Controllare che l'asta a cremagliera sia ben scorrevole tra la posizione di stop e la posizione di avviamento. A questo scopo azionare la leva d'arresto sul regolatore.</p>
<p>11. Press control rod with shutdown lever into stop position. Fit shutdown solenoid with new O- seal.</p> <p><b>Note:</b> Lightly oil O-seal.</p>	<p>11. A l'aide du levier d'arrêt pousser la crémaillère en position de stop. Monter l'électroaimant d'arrêt avec un joint torique neuf.</p> <p><b>Nota:</b> huiler légèrement le joint torique.</p>	<p>11. Per mezzo della leva d'arresto spingere l'asta a cremagliera nella posizione di stop. Montare l'elettromagnete di arresto munito di un nuovo O-ring.</p> <p><b>Nota:</b> Oliare leggermente l'O-ring.</p>



**Deutsch**

**Werkstatthandbuch BFM 1012/E, BFM 1013/E**

8. Neu ermittelte Ausgleichscheibe auf Rollenstößel auflegen.

**Hinweis:** Einspritzpumpen - Einbau, siehe Seite 4.00.37 ab Pos. 78 - 84.

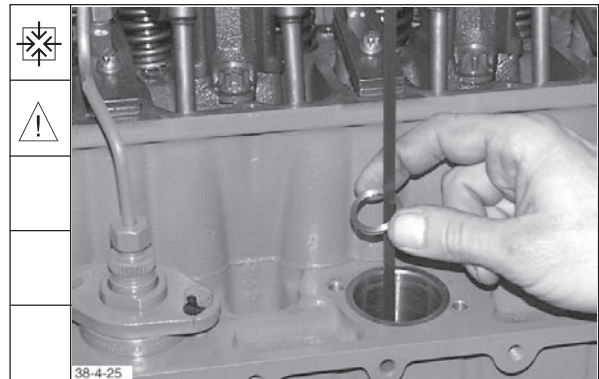

9. Einspritzventil ausbauen.

**Hinweis:** Bei Festsitz Ausziehvorrichtung Nr. 150 800 mit Auszieher Nr. 110 030 verwenden.

Einspritzventil und Einspritzleitung anbauen, siehe Seite 4.00.48 ab Pos. 114

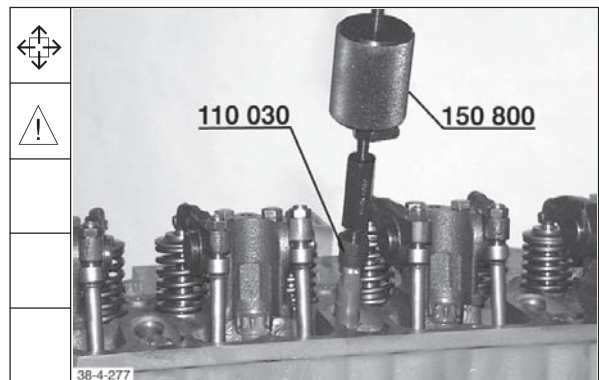

10. Rändel-Feststellschraube zurückdrehen. Andrückvorrichtung abbauen.

**Hinweis:** Prüfen ob Regelstange von Stopstellung zur Startstellung leichtgängig ist. Hierzu Abstellhebel des Reglers betätigen.

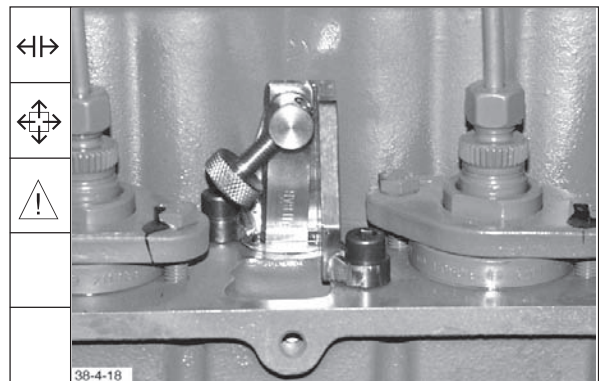

11. Regelstange mittels Abstellhebel in Stopstellung drücken. Abstellmagnet mit neuem Runddichtring einbauen.

**Hinweis:** Runddichtring leicht einölen.

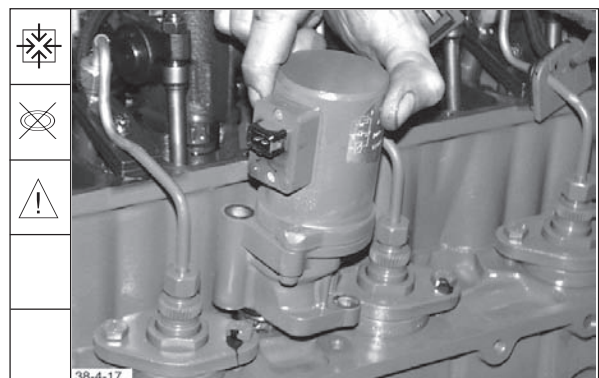

**Demontage und Montage, Motor komplett**  
**Disassembly and reassembly of complete engine**  
**Démontage et montage moteur complet**  
**Smontaggio e rimontaggio completo del motore**

**Werkstatthandbuch BFM 1012/E, BFM 1013/E**

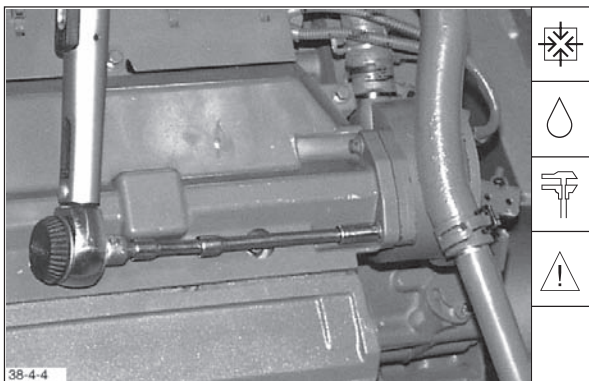
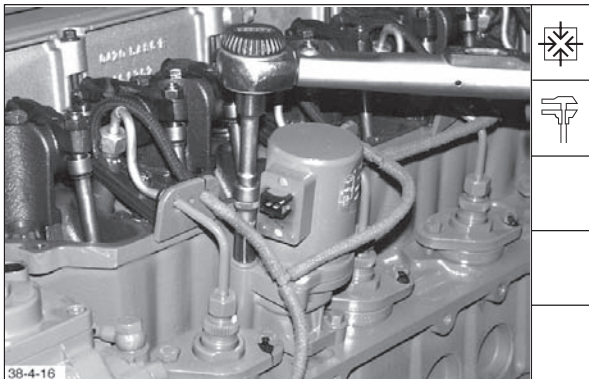

**Deutsch**

12. Schrauben mit einem Drehmoment von **21 Nm** festdrehen. Kabelstecker montieren.

13. Zylinderkopfhaube montieren. Schrauben mit einem Drehmoment von **9 ± 1 Nm** festdrehen.

**Hinweis:** Bei Bedarf Dichtung erneuern.

14. Runddichtring leicht einölen. Kurbelgehäuseentlüftung anbauen. Schrauben mit einem Drehmoment von **9 ± 1 Nm** festdrehen.

**Hinweis:** Bei Bedarf Runddichtring erneuern.

**Demontage und Montage, Motor komplett**  
**Disassembly and reassembly of complete engine**  
**Démontage et montage moteur complet**  
**Smontaggio e rimontaggio completo del motore**

English	Français	Italiano
12. Tighten bolts with a torque of <b>21 Nm</b> . Fit cable plug.	12. Serrer les vis au couple de <b>21 Nm</b> . Monter les fiches de câble.	12. Serrare le viti con una coppia di <b>21 Nm</b> . Innestare lo spinotto dei cavi.
13. Fit cylinder head cover. Tighten bolts with a torque of <b>9 ± 1 Nm</b> .	13. Monter le cache-culbuteurs et serrer les vis au couple de <b>9 ± 1 Nm</b> .	13. Montare il coperchio delle punterie. Stringere le viti con una coppia di <b>9 ± 1 Nm</b> .
<b>Note:</b> Renew gasket if necessary.	<b>Nota:</b> au besoin renouveler le joint.	<b>Nota:</b> Se necessario sostituire la guarnizione.
14. Lightly oil O-seal. Fit crankcase breather. Tighten bolts with a torque of <b>9 ± 1 Nm</b> .	14. Huiler légèrement le joint torique. Monter l'évent de carter et serrer les vis au couple de <b>9 ± 1 Nm</b> .	14. Oliare leggermente l'O-ring. Rimontare lo sfiato dell'incastellatura del motore. Serrare le viti con una coppia di <b>9 ± 1 Nm</b> .
<b>Note:</b> Renew O-seal if necessary.	<b>Nota:</b> au besoin renouveler le joint torique.	<b>Nota:</b> Se necessario sostituire l'O-ring.

**Demontage und Montage, Motor komplett**  
**Disassembly and reassembly of complete engine**  
**Démontage et montage moteur complet**  
**Smontaggio e rimontaggio completo del motore**

---

**Werkzeuge**

**Tools**

**Outils**

**Attrezzi**

**BFM 1012/1013**



**Wir bitten Sie, alle Bestellungen von Spezialwerkzeugen direkt an die  
Fa. Wilbär, D-42826 Remscheid, Postfach 14 05 80, Fax 02191 / 8 10 92,  
zu richten.**

**Please order all your special tools direct from  
Messr. Wilbär, D-42826 Remscheid, Postfach 14 05 80, Fax 02191 / 8 10 92**

**Nous vous prions de passer directement toutes vos commandes  
d'outillage spécial auprès de la société:  
Wilbär, D-42826 Remscheid, Postfach 14 05 80, Fax 02191 / 8 10 92**

**Si prega di effettuare tutte le ordinazioni di attrezzi speciali  
direttamente presso la  
Ditta Wilbär, D-42826 Remscheid, Postfach 14 05 80, Fax 02191 / 8 10 92**

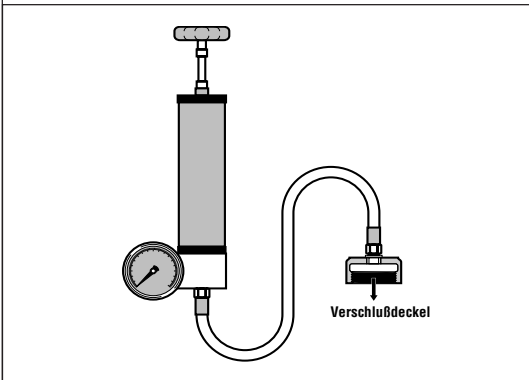
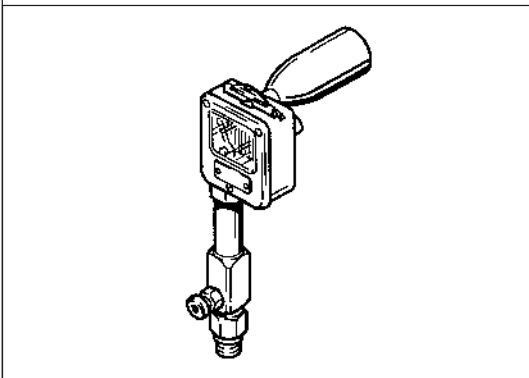
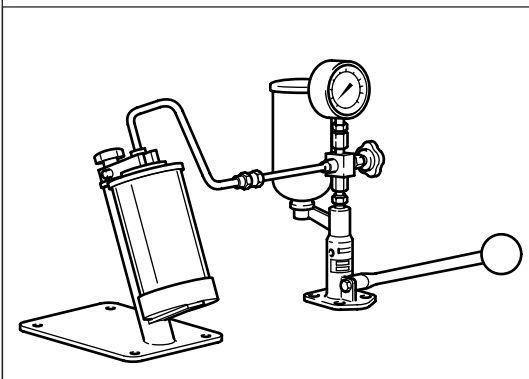
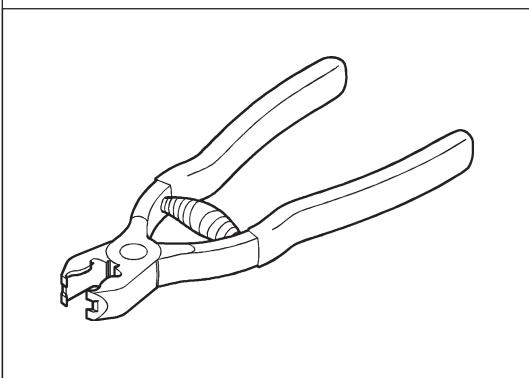
Deutsch	English	Français	Italiano	No.	BFM 1012	BFM 1013	Werkstatthandbuch BFM 1012/1013
Druckpumpe für Kühlmitteldichtheitsprüfung	Pressure Pump for coolant leakage	Pompe refulante pour contrôle de l'étanchéité du liquide de refroidisseur	Pompa per il controllo della tenuta del sistema di raffreddamento	8002	●	●	
Kompressionsdruckprüfer	Compression tester	Compressiomètre	Apparecchio di misura della pressione di compressione	8005	●	●	
Düsenprüfgerät	Nozzle tester	Banc d'essais d'injecteurs	Apparecchio di prova dei polverizzatori	8008	●	●	
Cobraklemmenzange	Cobra clamp pliers	Pince à colier Cobra	Pinza per morsetti cobra	8011	●	●	

**Werkstatthandbuch BFM 1012/1013**

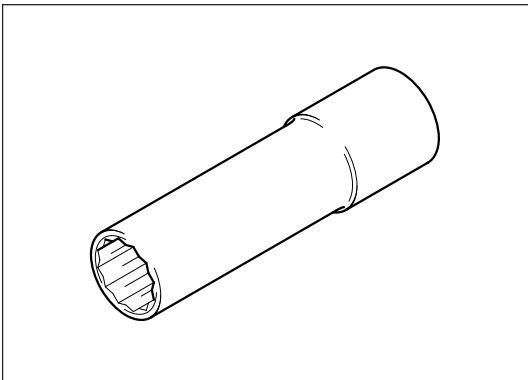
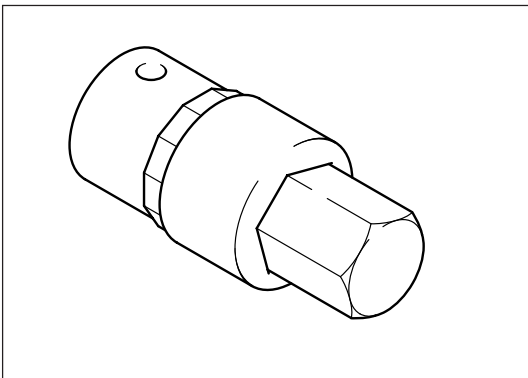
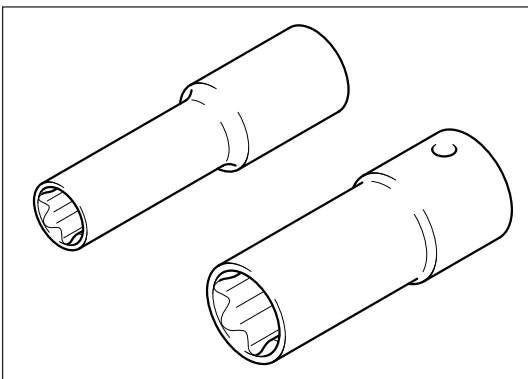
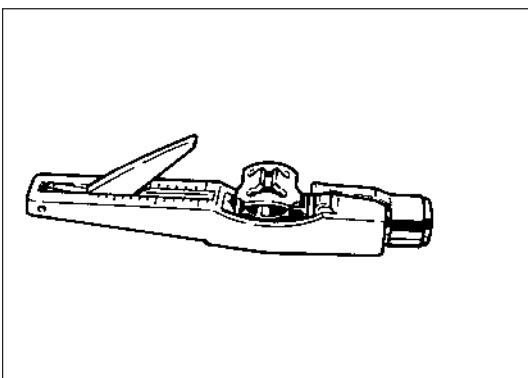
	BFM 1012	BFM 1013	No.	Deutsch	English	Français	Italiano
	●	●	<b>8012</b>	Stecknuß SW 15, lange Ausführung für Einspritzventil (Überwurfmutter)	Socket a/flats 15, long version for injector (Cap nut)	Douille de 15 modèle long pour injecteur (écrouaccord)	Chiave a bussola SW 15, esecuzione lunga per iniettori (dadi per raccordi)
	●	●	<b>8112</b>	Schraubendrehereinsatz	Screw driver socket	Embout de tournevis	Inserto per cacciavite
	●	●	<b>8113</b>	Torx-Steckschlüssel-Einsätze, lange Ausführung	Torx sockets long version	Embouts de clé à douille Torx, modèle long	Inserti per chiavi a tubo Torx, esecuzione lunga
	●	●	<b>8114</b>				
	●	●	<b>8115</b>	Keilriemenspannungsmeßgerät	V-belt tension gauge	Appareil de vérification de la tension de la courroie trapézoïdale	Attrezzo di misura della tensione delle cinghie trapezoidali

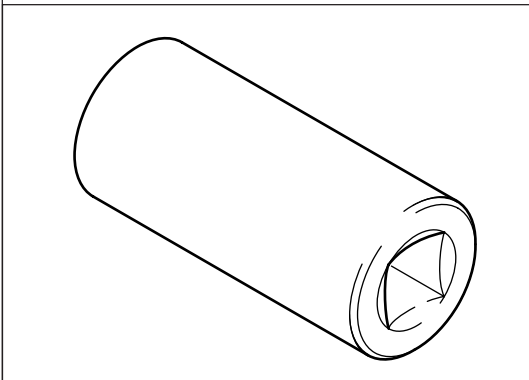
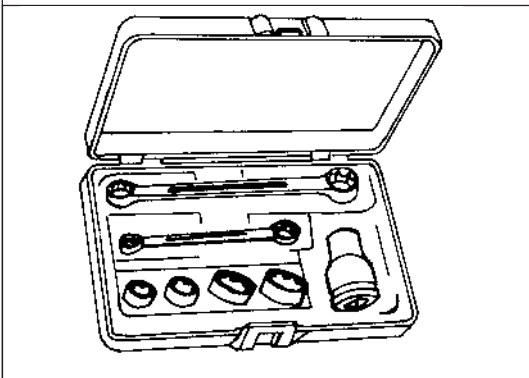
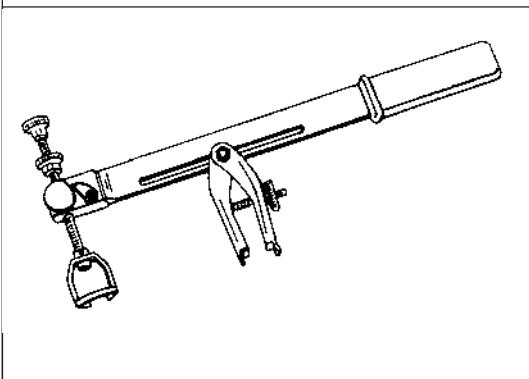
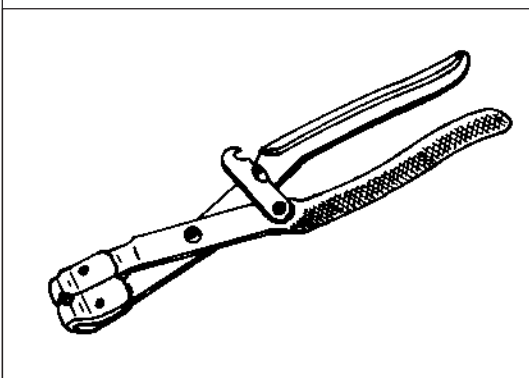

Deutsch	English	Français	Italiano	No.	BFM 1012	BFM 1013	Werkstatthandbuch BFM 1012/1013
Verdrehschlüssel (Vielzahn) für Einspritzpumpe	Serrated wrench for turning injection pump	Clé polygonale pour pompe d'injection	Chiave (a molti denti) per la pompa d'iniezione	<b>8117</b>	●	●	
Torx-Werkzeugsatz	Torx tool kit	Jeu d'outils Torx	Kit di utensili Torx	<b>8189</b>	●	●	
Ventilfedermontagehebel	Valve spring assembly lever	Lever de montage pour ressort de soupape	Leva per il montaggio delle molle delle valvole	<b>9017</b>	●	●	
Federklemmenzange	Spring clamp pliers	Pince à crampon élastique	Pinza a molla per morsetti	<b>9088</b>	●	●	

Werkstatthandbuch BFM 1012/1013

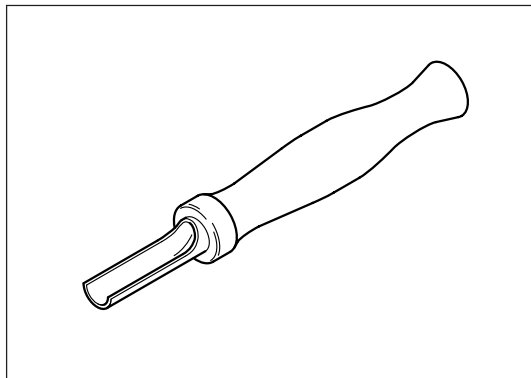
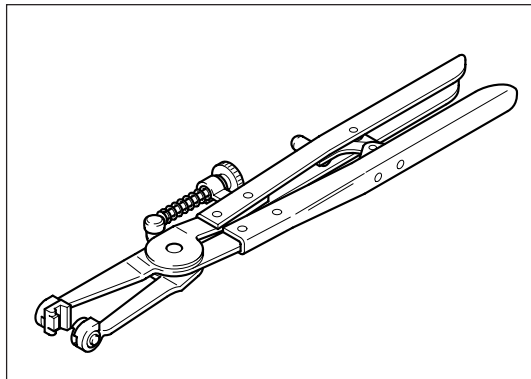

● BFM 1012

● BFM 1013

No.

9090

9115

Deutsch English Français Italiano

Federklemmenzange

Spring clamp pliers

Pince à crampon élastique

Pinza a molla per morsetti

Hilfswerkzeug für Glühkerzen-Kabelkupplung

Auxiliary tool for glow plug cable coupler

Outil auxiliaire pour raccords de câbles de bougies de préchauffage

Utensile ausiliario per il giunto dei cavi delle candele di preriscaldamento

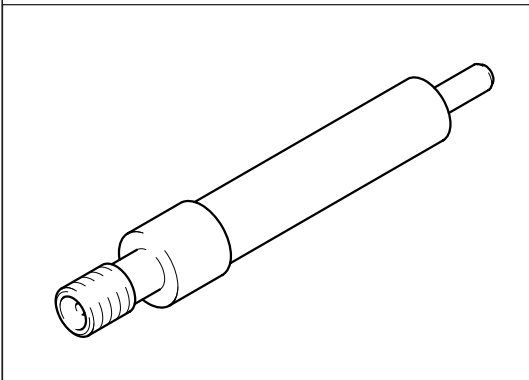
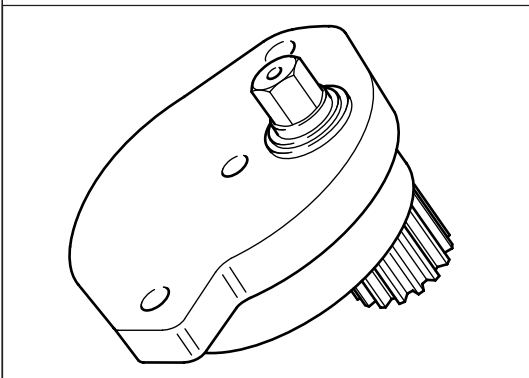
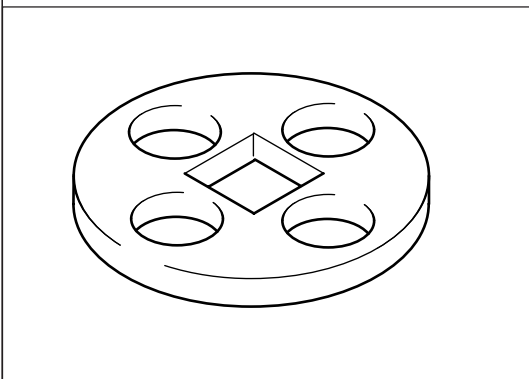
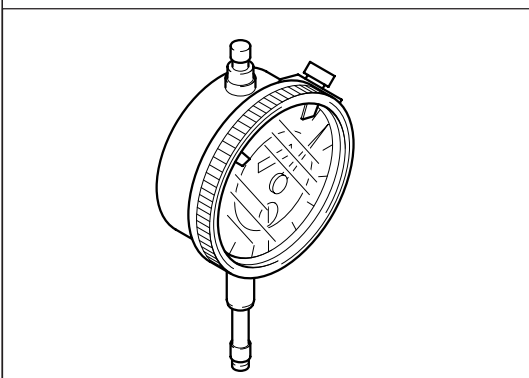
Deutsch	English	Français	Italiano	No.	BFM 1012	BFM 1013	Werkstatthandbuch BFM 1012/1013
Anschlußstück für Kompressionsdruckprüfer	Connector for compression tester	Raccord pour compressiomètre	Raccordo per l'apparecchio di misura della pressione di compressione	100 110	●	●	
Durchdrehvorrichtung	Turning gear	Dispositif vireur	Dispositivo per virare l'albero a gomiti	100 320	●	●	
Durchdrehvorrichtung	Turning gear	Dispositif vireur	Dispositivo per virare l'albero a gomiti	100 330	●	●	
Meßuhr M2T mit Feststellring	Dial gauge M2T with locking ring	Comparteur M2T avec bague d'immobilisation	Comparatore M2T con anello di arresto	100 400	●	●	

Werkstatthandbuch BFM 1012/1013

BFM 1012

BFM 1013

No.

Deutsch English Français Italiano

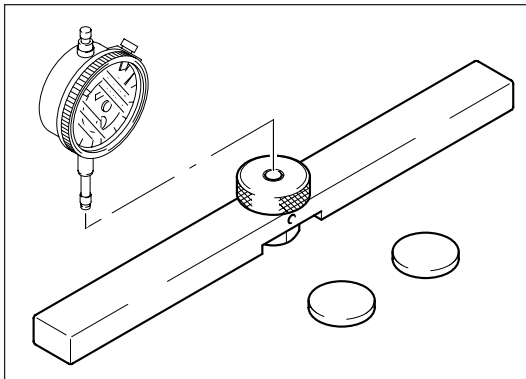

●

●

100 750

Meßbalken mit Abstandsblättchen zum Messen des OT und des Kolbenüberstandes

Measuring bar with spacers for gauging TDC and piston projection

Barre de mesure avec plaquettes d'écartement pour mesurer le PMH et la cote de dépassement du piston

Sbarra di misura con distanziatori per la misurazione del PMS e della sporgenza del pistone

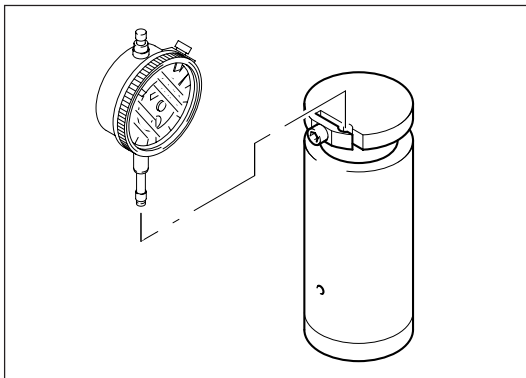

●

●

100 780

Meßvorrichtung für Grundkreismessung „Einspritzpumpe und Förderbeginn“

Measuring device for base circle measurement „injection pump and commencement of delivery“

Dispositif de mesure du cercle de base „pompe d'injection et début d'injection“

Dispositivo per la misurazione del cerchio di base “pompa d'iniezione ed inizio di mandata”

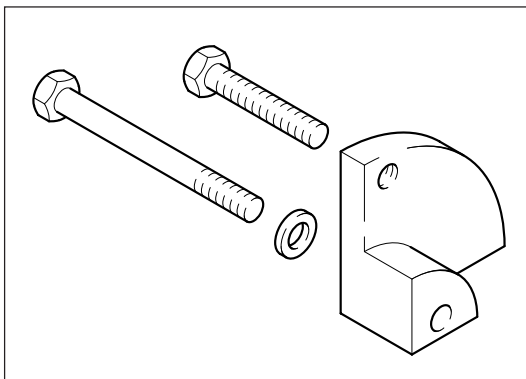

●

●

100 800

Meßgerät zum Messen und Blockieren der Regelstange

Measuring device for measuring and locking control rod

Appareil de mesure et de blocage de la crémaillère

Dispositivo per la misurazione ed il bloccaggio dell'asta a cremagliera

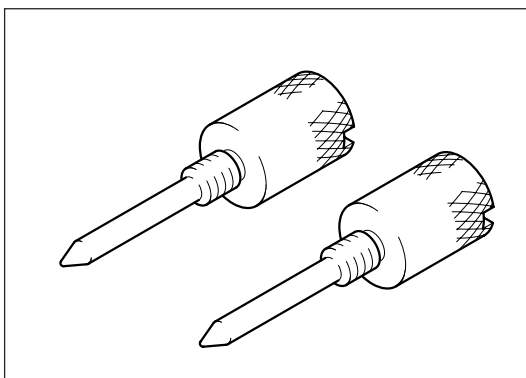

●

100 810

Einstellbolzen für MAG-Wellen.

Adjusting pin for mass balancing shafts

Pige de calage pour arbres à masses d'équilibrage (MAG)

Perno di regolazione per gli alberi delle masse controrotanti

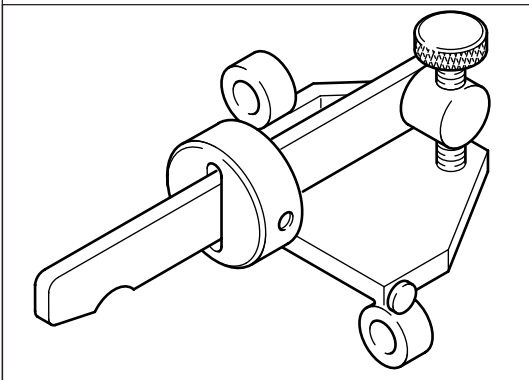
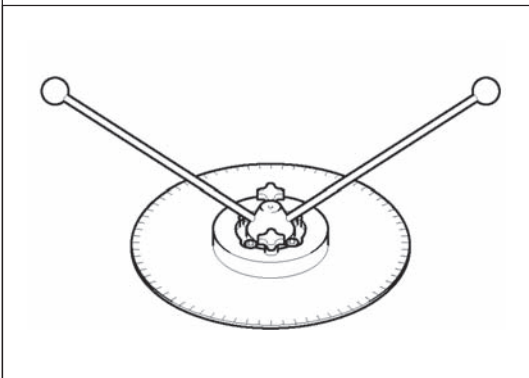
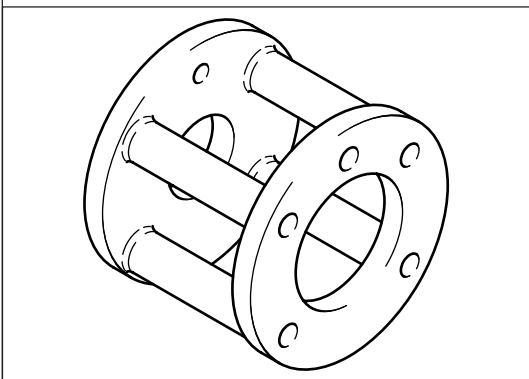
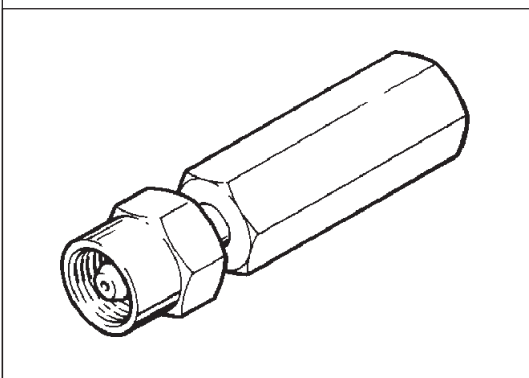
Deutsch	English	Français	Italiano	No.	BFM 1012	BFM 1013	Werkstatthandbuch BFM 1012/1013
Andrückvorrichtung für Regelstange	Press-on device for control rod	Dispositif de montage de crémaillère	Dispositivo di spinta per l'asta a cremagliera	100 830	●	●	
Gradscheibe 360° mit Befestigung an der Schwungscheibe für OT und FB Einstellung	Graduated disc 360° with device for fastening to flywheel for TDC and COD setting	Disque gradué 360° avec fixation sur volant moteur pour PMH et point de calage du début d'injection	Disco graduato per 360° con sistema di attacco alla flangia del volante per la regolazione del PMS e dell'inizio di mandata	101 020	●	●	
Adapter für Gradscheibe	Adapter for graduated disc	Adaptateur pour disque gradué	Adattatore per il disco graduato	101 030	●	●	
Auszieher für Einspritzventil in Verbindung mit 150 800	Extractor for injectors, to be used with tool 150 800	Extrcteur pour injecteur, à utiliser avec 150 800	Estrattore per l'iniettore utilizzabile assieme al dispositivo di estrazione 150 800	110 030	●	●	

Werkstatthandbuch BFM 1012/1013

● BFM 1012

● BFM 1013

No.

Deutsch English Français Italiano

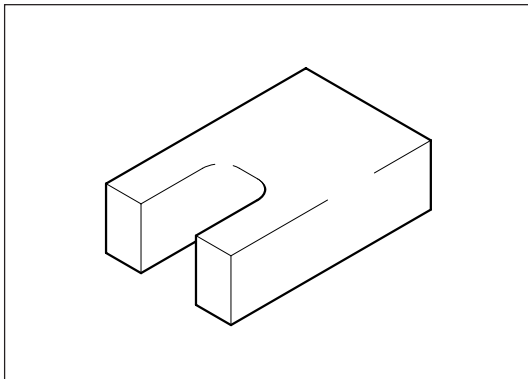

● 110 110

Halter für Einspritzventil SW11  
 Dolly for injector a/flats 11  
 Dispositif d'immobilisation d'injecteur SW 11  
 Dispositivo di fissaggio dell'iniettore

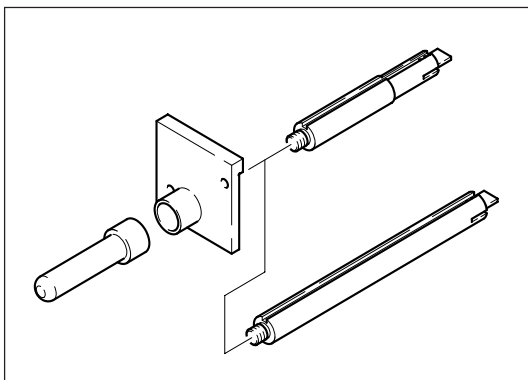

● 110 470

● 110 480

Montagewerkzeug für Regelstangen-Buchsen  
 Assembly tool for control rod sleeves  
 Outil de montage pour bague de crémaillère  
 Attrezzo di montaggio per le boccole dell'asta a cremagliera

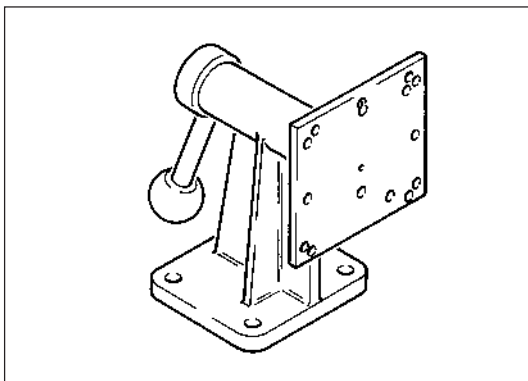

● 120 900

Aufspannbock für Zylinderkopf  
 Swivelling clamping stand for cylinder head  
 Chevalet d'ablocage pour culasse  
 Supporto per il fissaggio della testa cilindri

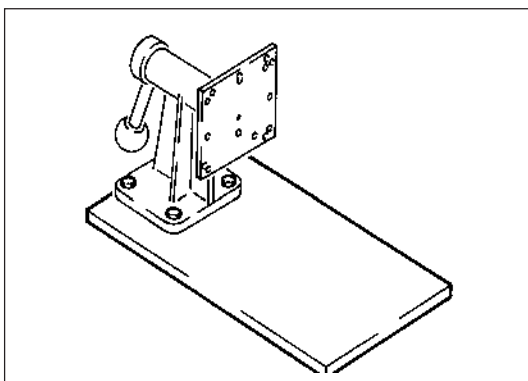

● 120 910

Aufspannplatte für 120 900  
 Clamping plate for 120 900  
 Plaque d'ablocage pour 120 900  
 Piastra per il fissaggio del supporto 120 900

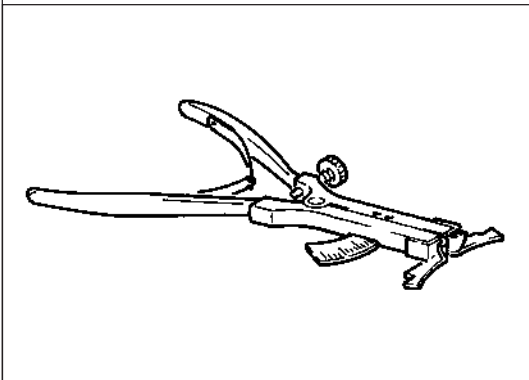
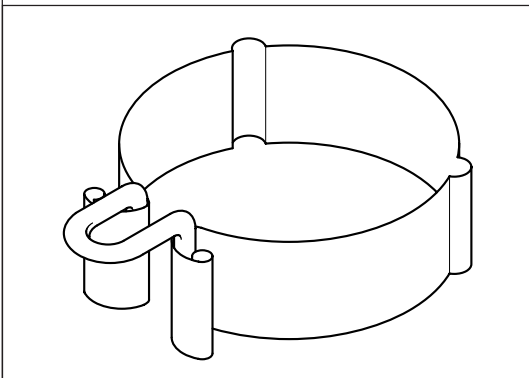
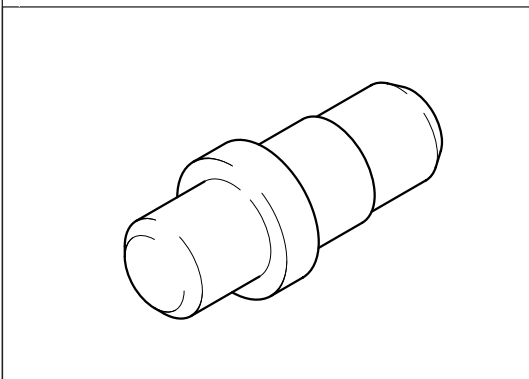
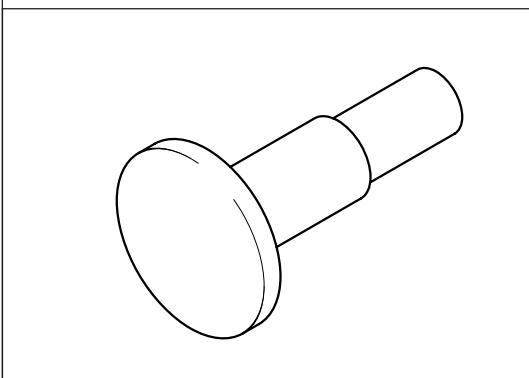
Deutsch	English	Français	Italiano	No.	BFM 1012	BFM 1013	Werkstatthandbuch BFM 1012/1013
Kolbenring-Auflegezange	Piston ring pliers	Pince à monter les segments de piston	Pinza per il montaggio delle fasce elastiche	130 300	●	●	
Kolbenringspannband	Piston ring compressor	Collier à comprimer les segments de piston	Espansore per le fasce elastiche del pistone	130 630	●		
				130 640		●	
Montagewerkzeug für Kolbenbolzenbuchse	Assembly tool for small end bush	Outil de montage de bague de pied de bielle	Attrezzo per il montaggio della boccola dello spinotto	131 070	●		
				131 090		●	
Demontagewerkzeug für Kolbenbolzensicherungsring	Disassembly tool for piston pin circlip	Appareil de démontage de circlip d'axe de piston	Attrezzo per lo smontaggio dell'anello di sicurezza dello spinotto	131 080	●		

**Werkstatthandbuch BFM 1012/1013**

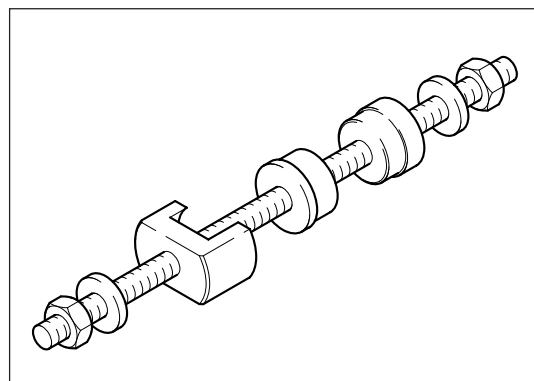
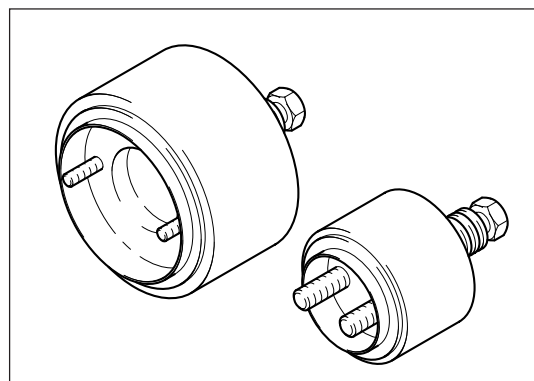
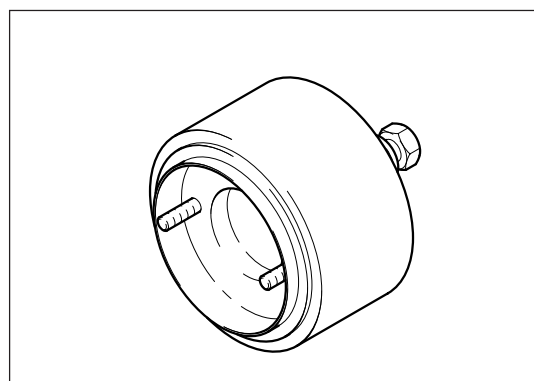
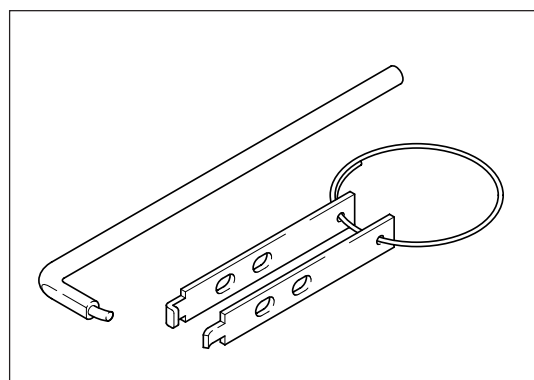

● BFM 1012

● BFM 1013

**No.**

**Deutsch English Français Italiano**

● **142 710**

Demontagewerkzeug (Haken) für Kurbelwellendichtringe vorn und hinten

Puller (hook) for front and rear crankshaft seals

Outil de démontage (crochet) de joint d'étanchéité de vilebrequin AV et AR

Attrezzo (gancio) per lo smontaggio degli anelli paraolio anteriore e posteriore dell'albero a gomiti

● **142 890**

Montagewerkzeug für Kurbelwellendichtring hinten

● **142 910**

Assembly tool for rear crankshaft seal

Outil de montage de joint d'étanchéité de vilebrequin AR

Attrezzo per il montaggio dell'anello paraolio posteriore dell'albero a gomiti

● **142 900**

Montagewerkzeug für Kurbelwellendichtring vorn

● **142 920**

Assembly tool for front crankshaft seal

Outil de montage de joint d'étanchéité de vilebrequin AV

Attrezzo per il montaggio dell'anello paraolio anteriore dell'albero a gomiti

● **143 780**

Montagewerkzeug für MAG-Buchsen

Assembly tool for engine balancer bushes

Outil de montage de douilles d'arbres à masses d'équilibrage

Attrezzo per montare le boccole degli alberi controrotanti

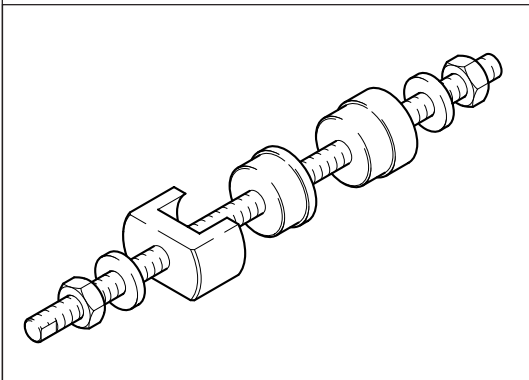
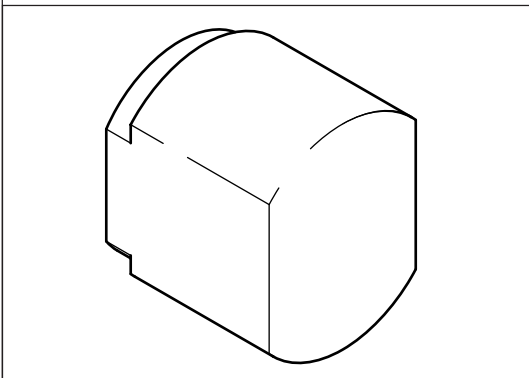
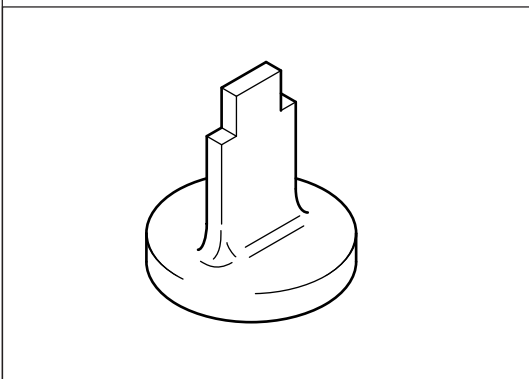
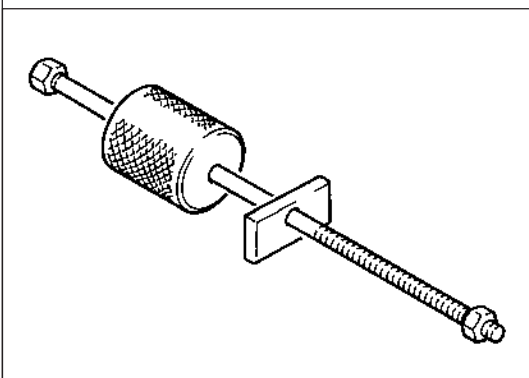

Deutsch	English	Français	Italiano	No.	BFM 1012	BFM 1013	Werkstatthandbuch BFM 1012/1013
Montagewerkzeug für Nockenwellen-Buchsen	Assembly tool for camshaft sleeves	Outil de montage de douilles d'arbre à cames	Attrezzo per il montaggio delle boccole dell'albero a camme	143 790	●		
Montagewerkzeug für Zylinderlaufbuchse	Assembly tool for cylinder liner	Outil de montage pour chemise	Attrezzo per il montaggio delle camicie dei cilindri	150 100	●		
Montagewerkzeug für Druckregelventil	Assembly tool for pressure control valve	Outil de montage pour soupape de régulation de pression	Attrezzo per il montaggio della valvola di regolazione della pressione	150 110	●		
Ausziehvorrichtung	Extractor	Extracteur	Estrattore	150 800	●	●	

Werkstatthandbuch BFM 1012/1013

BFM 1012

BFM 1013

No.

Deutsch English Français Italiano

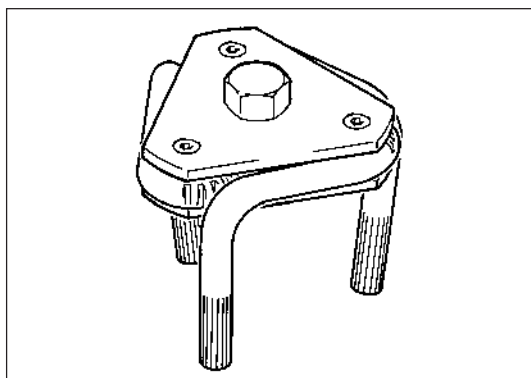

•

•

170 050

Spezialvorrichtung zum Abschrauben der Filterpatrone

Special device for screwing off filter cartridge

Dispositif spécial pour dévisser les cartouches filtrantes

Attrezzo speciale per svitare la cartuccia del filtro

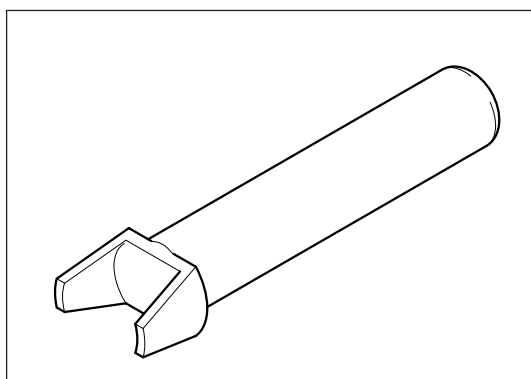

•

•

170 090

Montagewerkzeug für Kühlmittelthermostat

Assembly tool for coolant thermostat

Outil de montage de thermostat à réfrigérant

Attrezzo per montare il termostato del liquido refrigerante

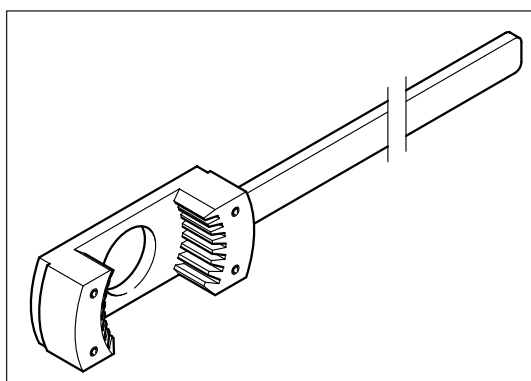

•

•

170 630

Gegenhalter für Zahnrad Luftpresser

Dolly for air compressor gear

Dispositif de maintien pour pignon de compresseur d'air

Attrezzo per bloccare il pignone del compressore

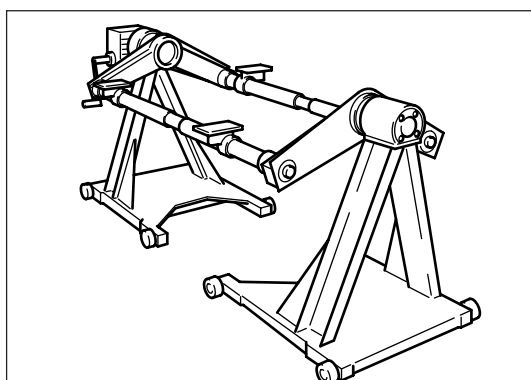

•

6066

Motormontagebock für doppelseitige Aufspannung

Engine assembly stand for double-sided chucking

Chevalet de montage moteur avec double ablocage

Cavalletto di montaggio con fissaggio del motore su ambedue i lati

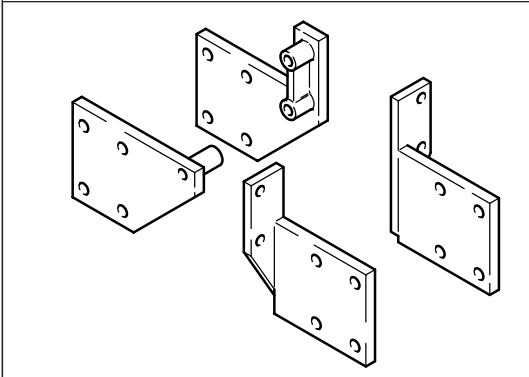
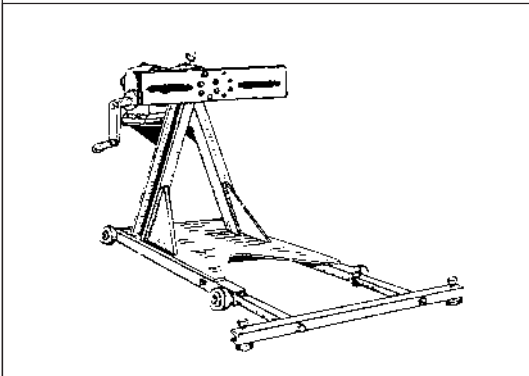
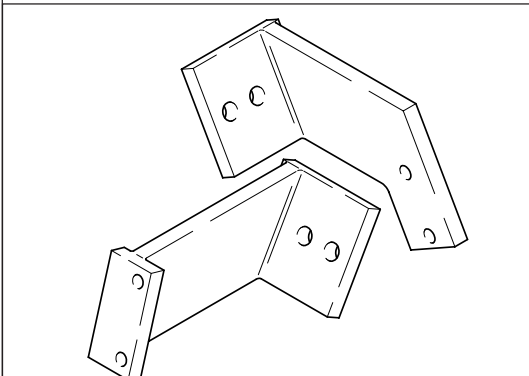
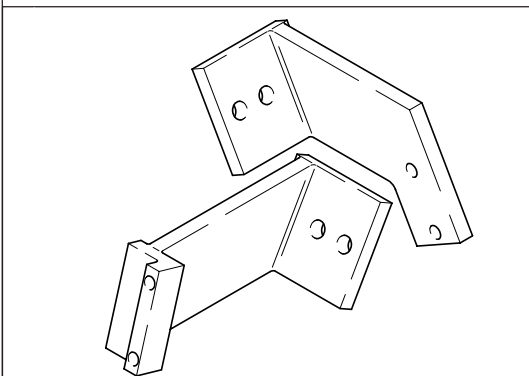
Deutsch	English	Français	Italiano	No.		Werkstatthandbuch BFM 1012/1013
1 Satz Aufspannwinkel für doppelseitige Aufspannung	1 Set of angled clamping plates for double-sided chucking	1 jeu d'équerre de fixation pour double ablocage	1 kit di angolari per il fissaggio del motore su ambedue i lati	6066/158	●	
Motormontagebock für einseitige Aufspannung	Engine assembly stand for one-sided chucking	Chevalet de montage moteur pour simple ablocage	Cavalletto di montaggio con fissaggio del motore su di un solo lato	6067	●	
1 Satz Aufspannwinkel für Motor mit externer Kühlung	1 Set of angled clamping plates for engine with external cooling system.	1 jeu d'équerre de fixation pour moteur à refroidissement externe	1 kit di angolari per il fissaggio dei motori con raffreddamento esterno	6067/118	●	
1 Satz Aufspannwinkel für Motor mit integrierter Kühlung.	1 Set of angled clamping plates for for engine with integrated cooling system	1 jeu d'équerre de fixation pour moteur à refroidissement intégré	1 kit di angolari per il fissaggio dei motori con raffreddamento integrato	6067/119	●	

BFM 1012

BFM 1013

